

DS3000PE

High Line: 3000 W Low Line: 1350 W

Data Sheet

Distributed Power Bulk Front-end Single Output Standard

Total Output Power:

3000 W continuous
208 Vac to 264 Vac, 3000 W¹
90 Vac to 140 Vac, 1350 W

SPECIAL FEATURES

- 3000 W output power
- High-power and narrow form factor
- 6 units can fit in a 19" inch for a total of 16.2 kW
- High-density design: 24 W/in³
- Active Power Factor Correction
- EN61000-3-2 harmonic compliance
- Inrush current control
- 80plus platinum efficiency
- N+1 or N+N redundant
- Hot-pluggable
- Active current sharing
- Full digital control
- PMBus Compliant
- Accurate input power reporting
- Compatible with Artesyn's universal PMBus GUI
- Two-year warranty

COMPLIANCE

- Conducted/Radiated EMI EN55022 Class A Limits + 6 dB margin
- ROHS

SAFETY

- UL/cUL
- DEMKO+ CB Report EN60950
- BSMI
- CE Mark
- China CQC



Electrical Specifications

Input	
Input Voltage range:	90-140 Vac, 1350 W 208 to 264 Vac ¹ , 3000 W
Frequency:	47 Hz to 63 Hz
Efficiency:	94.0% peak
Max Input Current:	17.5 Arms
Inrush Current:	55 Apk
Conducted EMI:	Class A
Radiated EMI:	Class A
Power Factor:	>0.97, typical
ITHD:	10%
Leakage Current:	0.58 mA
Hold-up time:	11 ms

Ordering Information

DS3000PE-3	Standard Airflow
DS3000PE-3-001	Reverse Airflow

¹ 2700 W output rating at 180 Vac

Electrical Specifications

Output			
Main DC Output	MIN	NOM	MAX
Nominal setting:	-0.30%	12	0.30%
Total output regulation range:	11.4 V		12.6 V
Dynamic load regulation range:	11.4 V		12.6 V
Output ripple:			120 mVp-p
Output current:	2 A ⁴		250 A ⁵
Current sharing:	Within +/-13.8 A of each other		
Capacitive loading:	1,000 uF		15,000 uf
Start-up from AC to output:			2100 ms
Output rise time:	2 ms		60 ms
Standby DC Output			
Nominal setting:	-1%	3.3 V	1%
Total output regulation range:	11.4 V		12.6 V
Dynamic load regulation range:	11.4 V		12.6 V
Output ripple:			120 mVp-p
Output current:	0.5 A		4.5 A
Current sharing:		N/A	
Capacitive loading:	47 uF		560 uf
Start-up from AC to output:			1700 ms
Output rise time:	2 ms		60 ms
Protections			
Main Output			
Over-current protection ² :	104%		120%
Over-voltage protection ¹ :	13.5 V		15.0 V
Under-voltage Protection:	10.5 V		11.0 V
Over-temperature protection:		Yes	
Fan fault protection:		Yes	
Standby Output			
Over-current Protection ⁴ :	110%		150%
Over-voltage Protection ³ :	13.5 V		15.0 V
Under-voltage Protection:	9.6 V		11.0 V

¹ Latch mode

² Autorecovery if the overcurrent is less than 104% and last only for <500 ms.

³ Standby protection is auto-recovery

⁴ Minimum current for transient load response testing only. Unit is designed to operate and be within regulation range at zero load.

⁵ Reverse airflow model derates to 231.5 A

Control and Status Signals

Input Signals

PSON

Active LOW signal which enables/disables the main output. Pulling this signal LOW will turn-on the main output. Recommended pull-up resistor to 12 VSB is 8.2 k with a 3.0 k pull-down to ground. A 100 pF decoupling capacitor is also recommended.

		MIN	MAX
V_{IL}	Input logic level LOW		0.8 V
V_{IH}	Input logic level HIGH	2.0 V	5.0 V
I_{SOURCE}	Current that may be sourced by this pin		2 mA
I_{SINK}	Current that may be sunk by this pin at low state		0.5 mA

PSKIL

First break/last mate active LOW signal which enables/disables the main output. This signal will have to be pulled to ground at the system side with a 220 ohm resistor. A 100 pF decoupling capacitor is also recommended.

		MIN	MAX
V_{IL}	Input logic level LOW		0.8 V
V_{IH}	Input logic level HIGH	2.0 V	5.0 V
I_{SOURCE}	Current that may be sourced by this pin		2 mA
I_{SINK}	Current that may be sunk by this pin at low state		0.5 mA

A0, A1, A2

Addressing pins of the power supply for I²C communications. Refer to the addressing tables below.

		MIN	MAX
	Internal pull-ups to 3.3V. It is recommended for the system to have pull-ups and decoupling on the address lines for better noise immunity.	R = 22 k ohm	C = 47 pF
V_{IL}	Input logic level LOW		0.8 V
V_{IH}	Input logic level HIGH	2.0 V	5.0 V
I_{SOURCE}	Current that may be sourced by this pin		4 mA
I_{SINK}	Current that may be sunk by this pin	4 mA	

Output Signals

ACOK

Signal used to indicate the presence of AC input to the power supply. A logic level HIGH will indicate that the AC input to the power supply is within the operating range while a logic level LOW will indicate that AC has been lost.

This is an open collector/drain output. This pin is pulled high by a 1.0 k ohm resistor connected to 3.3 V inside the power supply. It is recommended that this pin be connected to a 100 pF decoupling capacitor and pulled down by a 100 k ohm resistor.

		MIN	MAX
V_{IL}	Output logic level LOW		0.6 V
V_{IH}	Output logic level HIGH	2.0 V	5.0 V
I_{SOURCE}	Current that may be sourced by this pin		3.3 mA
I_{SINK}	Current that may be sunk by this pin at low state		0.7 mA

Control and Status Signals

PWR_GOOD / PWOK

Signal used to indicate that main output voltage is within regulation range. The PWR_GOOD signal will be driven HIGH when the output voltage is valid and will be driven LOW when the output falls below the under-voltage threshold.

This signal also gives an advance warning when there is an impending power loss due to loss of AC input or system shutdown request. More details in the Timing Section.

This is an open collector/drain output. This pin is pulled high by a 1.0 k ohm resistor connected to 3.3 V inside the power supply. It is recommended that this pin be connected to a 100 pF decoupling capacitor and pulled down by a 10 k ohm resistor.

		MIN	MAX
V_{IL}	Output logic level LOW		0.8 V
V_{IH}	Output logic level HIGH	2.0 V	5.0 V
I_{SOURCE}	Current that may be sourced by this pin		3.3 mA
I_{SINK}	Current that may be sunk by this pin at low state		0.7 mA

PS_PRESENT

Signal used to indicate to the system that a power supply is inserted in the power bay. Recommended pull-up resistor to 12 VSB is 8.2 k with a 3.0 k pull-down to ground. A 100 pF decoupling capacitor is also recommended.

PS_INTERRUPT

Active low signal used by the power supply to indicate to the system that a change in power supply status has occurred. This event can be triggered by faults such as OVP, OCP, OTP, and fan fault. This signal can be cleared by a CLEAR_FAULT command. Recommended pull-up resistor to 12 VSB is 8.2 k with a 3.0 k pull-down to ground. A 100 pF decoupling capacitor is also recommended.

		MIN	MAX
V_{IL}	Output logic level LOW		0.8 V
V_{IH}	Output logic level HIGH	2.0 V	5.0 V
I_{SOURCE}	Current that may be sourced by this pin		4 mA
I_{SINK}	Current that may be sunk by this pin at low state		4 mA

BUS Signals

ISHARE

Bus signal used by the power supply for active current sharing. All power supplies configured in the system for n+n sharing will refer to this bus voltage in order to load share.

Voltage Range	The range of this signal for active sharing will be up to 8.0 V, which corresponds to the maximum output current.		
		MIN	MAX
I_{SHARE} Voltage	Input logic level LOW	7.75	8.25
	Voltage at 50% load, stand-alone unit	3.85	4.15
	Voltage at 0% load, stand-alone unit	0	0.3
I_{SOURCE}	Current that may be sourced by this pin		160 mA

SCL, SDA

Clock, data and addressing signals defined as per I²C requirements. The maximum system side resistor pull-up and decoupling capacitance

		MIN	MAX
V_L	Logic level LOW		0.8 V
V_H	Logic level HIGH	2.0 V	5.0 V

Note: All signal noise levels are below 400 mVpk-pk from 0 - 100 MHz.

I²C Addressing Table

FRU ADDRESSING			
A2	A1	A0	Address
HIGH	LOW	LOW	0 x A9
HIGH	LOW	HIGH	0 x AB
HIGH	HIGH	LOW	0 x AD
HIGH	HIGH	HIGH	0 x AF*

PMBus Addressing
Address
0 x B8
0 x BA
0 x BC
0 x BE

* Default address when A0 and A1 are open

Electrical Specifications

LED Indicators			
	AC GOOD LED	DC GOOD LED	FAULT LED
Color	GREEN	GREEN	AMBER
No AC input to PSU	Off	Off	Off
AC present, STBY ON, main output OFF	On	Off	Off
Main output ON	On	On	Off
Power supply failure (OVP, OTP, FAN FAULT)	Off	Off	Blinking

Firmware Reporting And Monitoring

Firmware Reporting And Monitoring			
		Accuracy Range	
Output loading	5 to 20%	20 to 50%	50 to 100%
Input voltage	±5%		
Input current	±0.55 A fixed error	±4%	
Input power	±10 W at < 100 W input	±5%	
Output voltage	±2%		
Output current	2.5 A fixed error	±2%	
Temperature	±5 degC on the operating range		
E_{IN}	±15% from 10% to 20% load	±5%	
Fan speed	±250 RPM		

PMBus	YES
Remote ON/OFF	YES

Timing Specifications

	Description	Min	Max	Unit
T_{sb_on}	Delay from AC being applied to standby output being within regulation	500	2000	ms
T_{sb_vout}	Delay from standby output to main output voltage being within regulation		1200	ms
T_{sb_ACOK}	Delay from standby output to ACOK assertion		40	ms
$T_{ac_on_delay}$	Delay from AC being applied to main output being within regulation		2200	ms
T_{pwok_on}	Delay from output voltages within regulation limits to PWOK asserted	100	1200	ms
T_{acok_delay}	Delay from loss of AC to assertion of ACOK		250	ms
$T_{pwok_hold-up}$	Delay from loss of AC to deassertion of PWOK	10		ms
$T_{vout_hold-up}$	Delay from loss of AC to main output falling out of regulation	11		ms
$T_{sb_hold-up}$	Delay from loss of AC to standby output being within regulation	150		ms
$T_{PWR_GOOD_Off}$	Delay from deassertion of PWOK to output falling out of regulation	1		ms
$T_{PSON_On_delay}$	Delay from PSON assertion to output being within regulation		350	ms

Timing Diagram

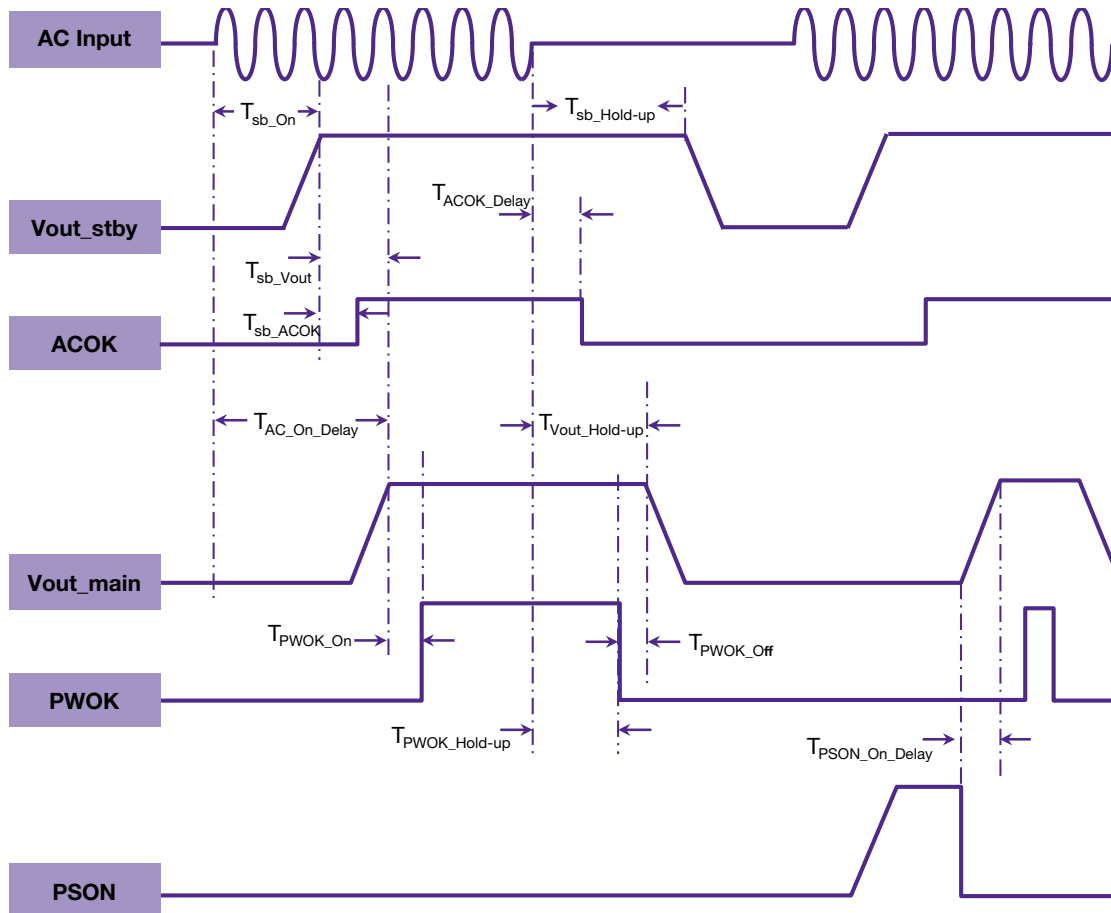

Environmental Specifications

Operating temperature:	Full power from 0 to 40 °C, derate output power by 2.5% per °C from 40 °C to 50 °C
Operating altitude:	up to 10,000 feet
Operating relative humidity:	20% to 80% non-condensing
Non-operating temperature:	-40 to +85 °C
Non-operating relative humidity:	10% to 95% non-condensing
Non-operating altitude:	up to 30,000 feet
Vibration and shock:	Standard operating/non-operating random vibration/shock
ROHS compliance:	Yes
MTBF:	400,000 hours
Operating life:	Minimum of 5 years
Reliability:	All electronic component derating analysis and capacitor life calculation is done at 25 degC ambient, maximum rated load, nominal input line voltage.

Mechanical Outline

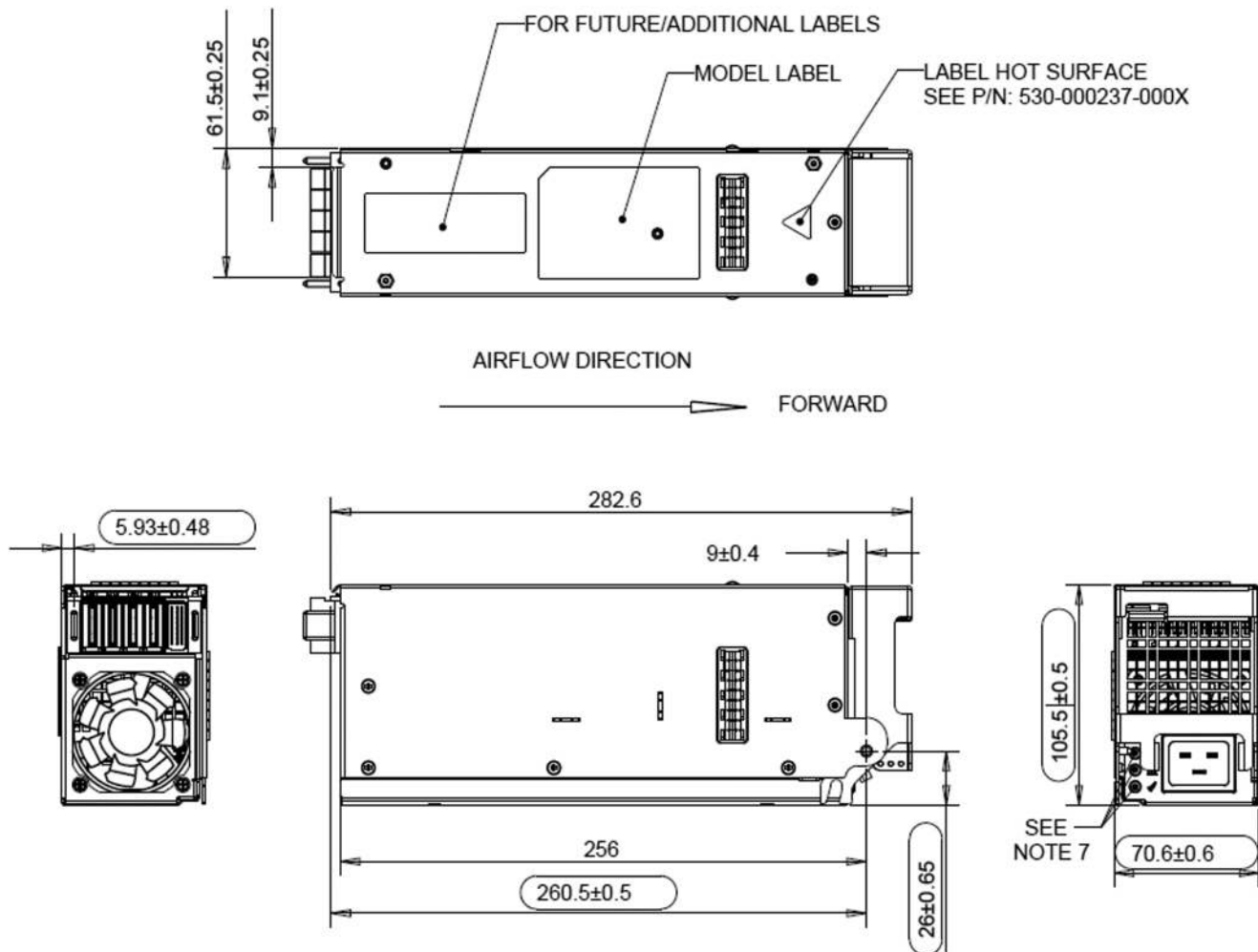

Connector Definitions

Output Connector Part Number	75555-104
Mating Connector Part Number	75541-104REVB1 or any other Molex recommended part

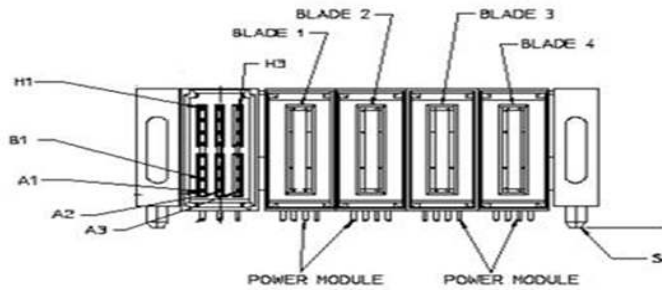

Pin	Signal Name	Amps per pin ¹
PB1	RETURN	150
PB2	RETURN	150
PB3	12 V	150
PB4	12 V	150
A1	PWR GOOD	N/A
A2	PSKILL	N/A
A3	PRESENT	N/A
B1	RETURN	N/A
B2	ISHARE	N/A
B3	RETURN	N/A
C1	PS_INTERRUPT	N/A
C2	RETURN	N/A
C3	ACOK	N/A
D1	RETURN	N/A
D2	PSON	N/A
D3	RESERVED	N/A
E1	SDA	N/A
E2	SCL	N/A
E3	A0	N/A
F1	RESERVED	N/A
F2	A1	N/A
F3	A2	N/A
G1	RESERVED	N/A
G2	RESERVED	N/A
G3	RESERVED	N/A
H1	12 VSB	2
H2	12 VSB	2
H3	12 VSB	2

WORLDWIDE OFFICES

Americas

2900 S.Diablo Way
Tempe, AZ 85282
USA
+1 888 412 7832

Europe (UK)

Waterfront Business Park
Merry Hill, Dudley
West Midlands, DY5 1LX
United Kingdom
+44 (0) 1384 842 211

Asia (HK)

14/F, Lu Plaza
2 Wing Yip Street
Kwun Tong, Kowloon
Hong Kong
+852 2176 3333

ARTESYN[™]
EMBEDDED TECHNOLOGIES

www.artesyn.com

While every precaution has been taken to ensure accuracy and completeness in this literature, Artesyn Embedded Technologies assumes no responsibility, and disclaims all liability for damages resulting from use of this information or for any errors or omissions. Artesyn Embedded Technologies, Artesyn and the Artesyn Embedded Technologies logo are trademarks and service marks of Artesyn Embedded Technologies, Inc. All other names and logos referred to are trade names, trademarks, or registered trademarks of their respective owners. © 2014 Artesyn Embedded Technologies, Inc.

For more information: www.artesyn.com/power
For support: productsupport.ep@artesyn.com