

LTR	DESCRIPTION	DWN	APPD	DATE
K1	ECO-09-025714	KK	AEG	17DEC09

NOTES :

- FOR USE ON MINI HD APPLICATOR (LEFT - RIGHT FEED).
- TINPLATING THICKNESS .000080 MIN - .000400 MAX. (INCH).
- MATERIAL PH.BRONZE ACC ASTM B103 ALLOY 511.
- REAR ROLLING MUST TOUCH TAB.

5 OBSOLETE PARTS: OBSOLETE CIS STREAMLINING PER D.RENAUD/D.SINISI

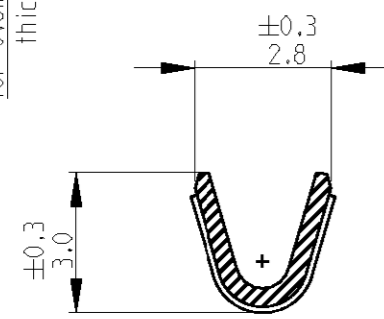
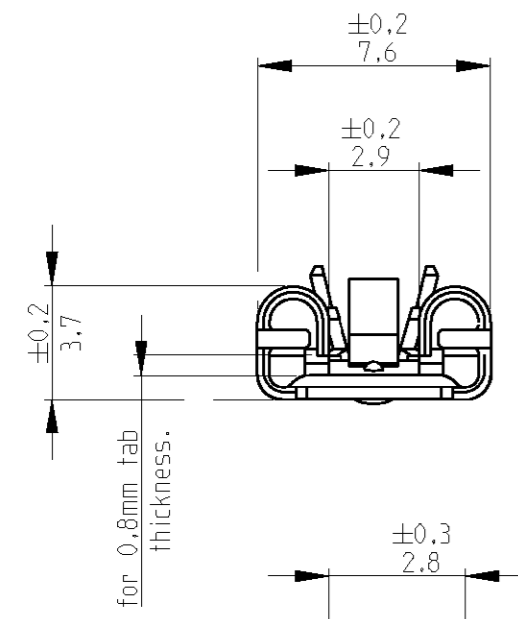
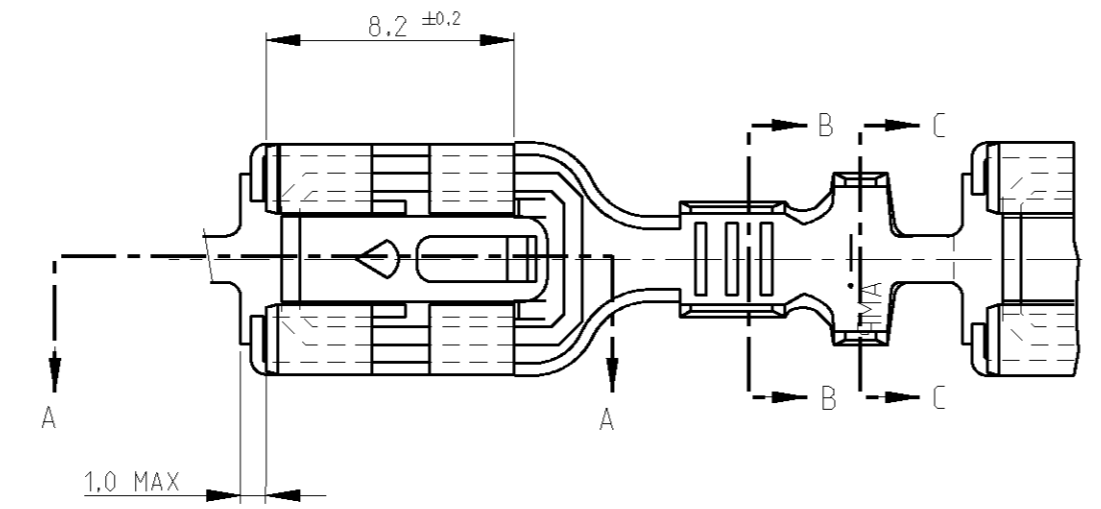

SECTION B - B

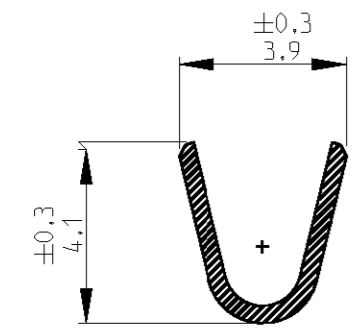

SECTION C - C

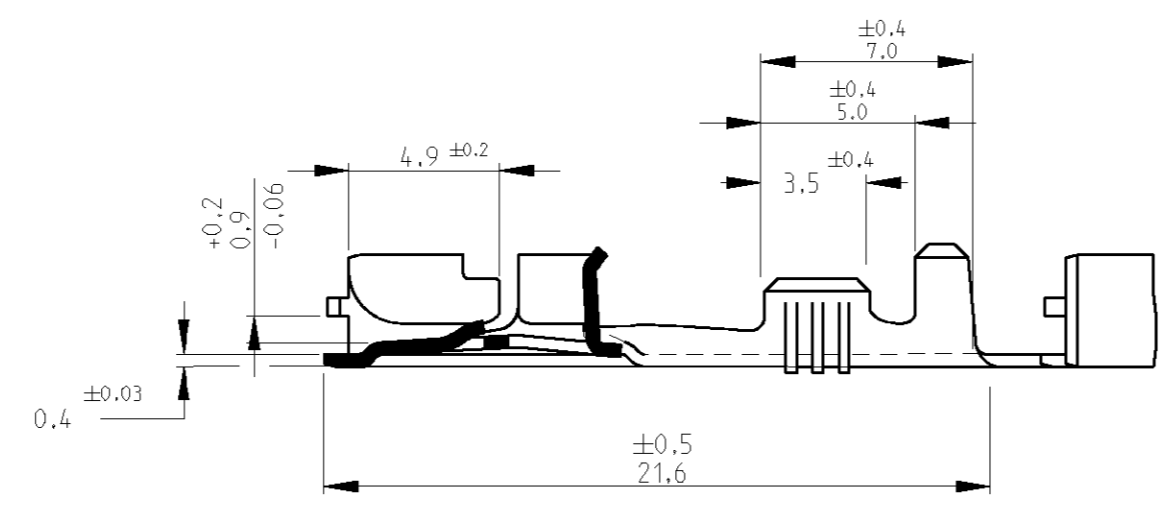

SECTION A - A

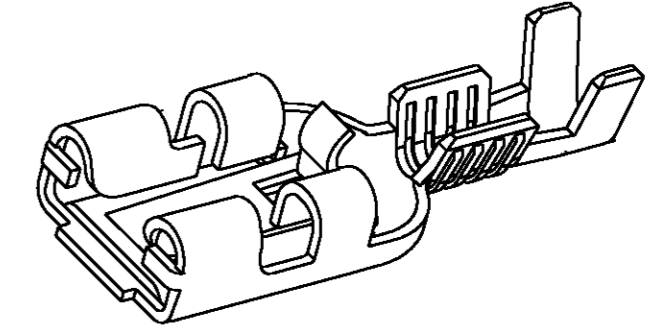
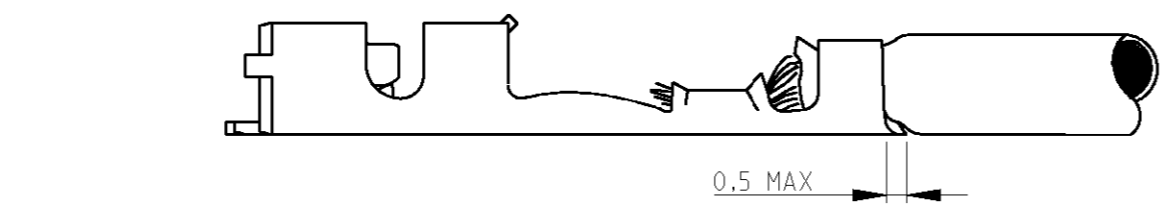
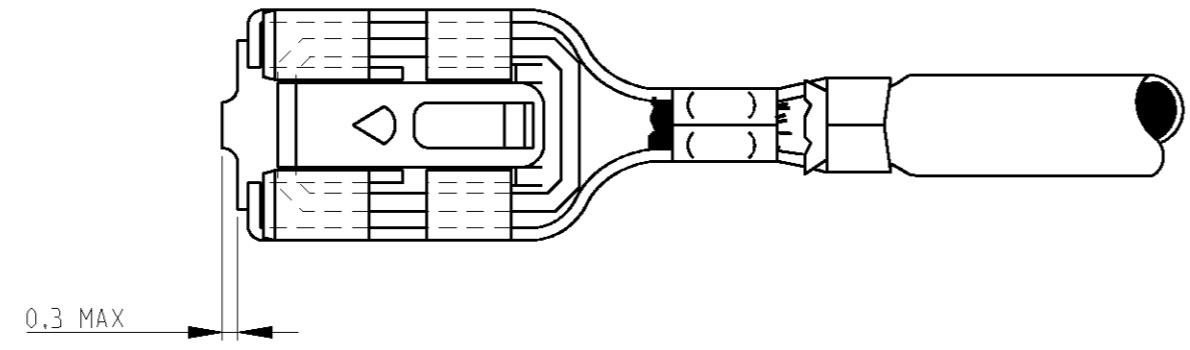

WIRE	CRIMP HEIGHT	CRIMP WIDTH
0.5mm?	1.43mm	.080 'F'
0.75mm?	1.52mm	.080 'F'
1.0mm?	1.61mm	.080 'F'

5 OBSOLETE

100015-4	PRE-TINPLATED	PH.BRONZE	216329-4
100015-3	SILVERPLATED	PH.BRONZE	216329-3
100015-2	TINPLATED	PH.BRONZE	216329-2
100015-1	UNPLATED	PH.BRONZE	216329-1
LOOSE PIECE NR.	FINISH	MATERIAL	PARTNUMBER

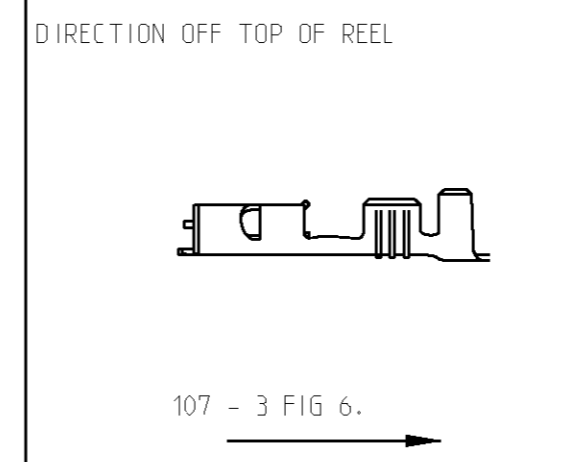

tyco Electronics TYCO ELECTRONICS AMP ESPAÑOLA S.A. BARCELONA ESPAÑA

THIS DRAWING IS UNPUBLISHED CUSTOMER DRAWING

FOR REFERENCE ONLY WILL NOT BE UPDATED

© COPYRIGHT 2002 - BY AMP-SPAIN ALL INTERNATIONAL RIGHTS RESERVED. AMP PRODUCTS MAY BE COVERED BY U.S. AND FOREIGN PATENTS AND/OR PATENTS PENDING.

DR. R.v.Lokven	DATE 24.04.89	WIRE RANGE 0.5-1.0mm?	NAME .250 L.I.F AUTOMOTIVE POS LOCK REC MKII.	REV. DATE D M Y
CHK. R.v.Lokven	DATE 24.04.89	INSUL.RANGE 1.4-2.3 DIA		17 12 09
APP. L.v.Soest	DATE 26-11-89	SIZE A2	SHEET 1 OF 1	DWG. No. C-216329

REV.LTR. K1