



ON Semiconductor®

<http://onsemi.com>

LC72725KV

CMOS IC

RDS(RBDS) Demodulation IC

Overview

The LC72725KV is IC that implement the signal processing required by the European Broadcasting Union RDS (Radio Data System) standard and by the US NRSC (National Radio System Committee) RBDS (Radio Broadcast Data System) standard. This IC include band-pass filter, demodulator, and data buffer on chip. RDS data can be read out from this on-chip memory by external clock input in slave operation mode.

Functions

- Bandpass filter: Switched capacitor filter (SCF)
- RDS Demodulation: 57KHz carrier and RDS data clock regeneration, biphase decode, differential decode.
- Buffer: 128 bit (about 100ms) can be restored in the on-chip data buffer RAM.
- Data output: Master or slave output mode can be selected.
- RDS-ID: Detect RDS signal which can be reset by RST signal input.
- Standby control: Crystal oscillator can be stopped.
- Fully adjustment free
- Low Voltage

Specifications

Absolute Maximum Ratings at Ta = 25°C, VSSd = VSSa = 0V

Parameter	Symbol	Pin Name	Conditions	Ratings	Unit
Maximum supply voltage	V _{DD} max	V _{DDd} , V _{DDa} *	V _{DDa} ≤ V _{DDd} + 0.3V	-0.3 to +6.5	V
Maximum input voltage	V _{IN1} max	TEST, MODE, XIN, RDCL, RST		-0.3 to V _{DDd} + 0.3	V
	V _{IN2} max	MPXIN, CIN		-0.3 to V _{DDa} + 0.3	V
Maximum output voltage	V _{O1} max	RDS-ID(READY)		-0.3 to +6.5	V
	V _{O2} max	XOUT, RDDA, RDCL		-0.3 to V _{DDd} + 0.3	V
	V _{O3} max	FLOUT		-0.3 to V _{DDa} + 0.3	V
Maximum output current	I _{O1} max	XOUT, FLOUT, RDDA, RDCL		+2.0	mA
	I _{O2} max	RDS-ID(READY)		+8.0	mA

* V_{DDa} ≤ V_{DDd} + 0.3V

Continued on next page.

LC72725KV

Continued from preceding page.

Parameter	Symbol	Pin Name	Conditions	Ratings	Unit
Allowable power dissipation	Pd max		Ta ≤ 85°C	100	mW
Operating temperature	Topr1		VDD = 2.7V to 5.5V	-20 to +70	°C
	Topr2		VDD = 3.0V to 5.5V	-40 to +85	°C
Storage temperature	Tstg			-40 to +125	°C

Stresses exceeding Maximum Ratings may damage the device. Maximum Ratings are stress ratings only. Functional operation above the Recommended Operating Conditions is not implied. Extended exposure to stresses above the Recommended Operating Conditions may affect device reliability.

Allowable Operating Ranges at Ta = -20 to +70°C, VSSd = VSSa = 0V, VDDd = VDDa = 2.7V to 5.5V
 Ta = -40 to +85°C, VSSd = VSSa = 0V, VDDd = VDDa = 3.0V to 5.5V

Parameter	Symbol	Pin Name	Conditions	Ratings			unit
				min	typ	max	
Supply voltage	VDD1	VDDd, VDDa	Ta = -20 to +70°C	2.7		5.5	V
	VDD2	VDDd, VDDa	Ta = -40 to +85°C	3.0		5.5	
Input high-level voltage	VIH1	TEST, MODE, RST		0.7VDDd		6.5	V
	VIH2	RDCL		0.7VDDd		VDDd	V
Input low-level voltage	VIL	TEST, MODE, RST, RDCL		0		0.3VDDd	V
Output voltage	VO1	RDDA, RDCL				VDDd	V
	VO2	RDS-ID(READY)				6.5	V
Input amplitude	VIN	MPXIN	f = 57±2kHz	1.6		50	mVrms
	VXIN	XIN		400		1500	mVrms
Guaranteed crystal oscillator frequencies	Xtal	XIN, XOUT	Cl ≤ 120Ω		4.332		MHz
Crystal oscillator operating range	TXtal	XIN, XOUT	Fo = 4.332MHz			±100	ppm
RDCL setup time	tCS	RDCL, RDDA		0			μs
RDCL high-level time	tCH	RDCL		0.75			μs
RDCL low-level time	tCL	RDCL		0.75			μs
Data output time	tDC	RDCL, RDDA				0.75	μs
READY output time	tRC	RDCL, READY				0.75	μs
READY low-level time	tRL	READY				107	ms

LC72725KV

Electrical Characteristics for the Allowable Operating Ranges

Parameter	Symbol	Pin Name	Conditions	Ratings			unit
				min	typ	max	
Input resistance	Rmpxin	MPXIN-VSSa	f = 57kHz		100		kΩ
	Rcin	CIN-VSSa	f = 57kHz		100		kΩ
Internal feedback resistance	Rf	XIN			1.0		MΩ
Center frequency	fc	FLOUT		56.5	57.0	57.5	kHz
-3dB band width	BW-3dB	FLOUT		2.5	3.0	3.5	kHz
Gain	Gain	MPXIN-FLOUT	f = 57kHz	28	31	34	dB
Stop band attenuation	Att1	FLOUT	$\Delta f = \pm 7\text{kHz}$	30			dB
	Att2	FLOUT	F < 45kHz, f > 70kHz	40			dB
	Att3	FLOUT	F < 20kHz	50			dB
Reference voltage output	Vref	Vref	VDDa = 3V		1.5		V
Hysteresis	VHIS	TEST, MODE, RST, RDCL			0.1VDDd		V
Output low-level voltage	VOL1	RDDA, RDCL	I = 2mA			0.4	V
	VOL2	RDS-ID(READY)	I = 8mA			0.4	V
Output high-level voltage	VOH	RDDA, RDCL	I = 2mA	VDDd-0.4			V
Input high-level current	I _{IH1}	TEST, MODE, RST, RDCL	V _I = 6.5V			5.0	μA
	I _{IH2}	XIN	V _I = VDDd	2.0		11	μA
Input low-level current	I _{IL1}	TEST, MODE, RST, RDCL	V _I = 0V			5.0	μA
	I _{IL2}	XIN	V _I = 0V	2.0		11	μA
Output off leakage current	IOFF	RDS-ID(READY)	V _O = 6.5V			5.0	μA
Current drain	I _{DD}	VDDd+VDDa	VDDd+VDDa (VDDd = VDDa = 3V)		5		mA

Package Dimensions

unit : mm (typ)

3178B

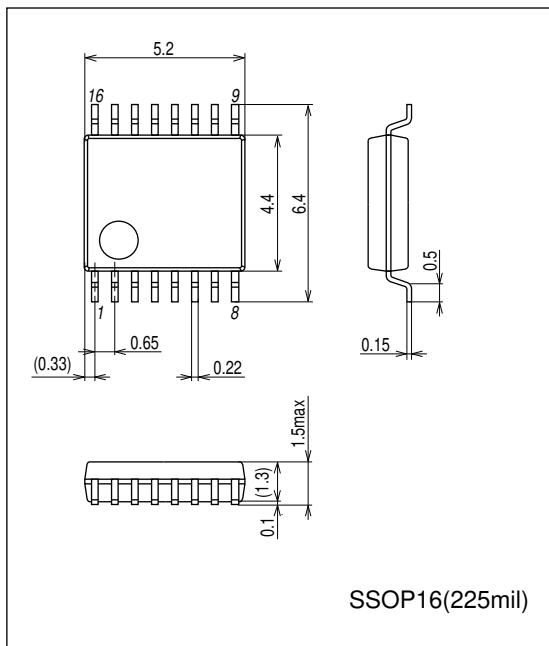

LC72725KV

Pin Assignment

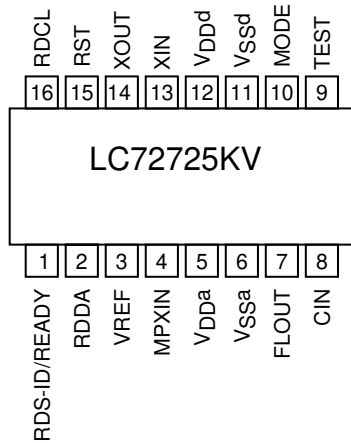

Top view

Block Diagram

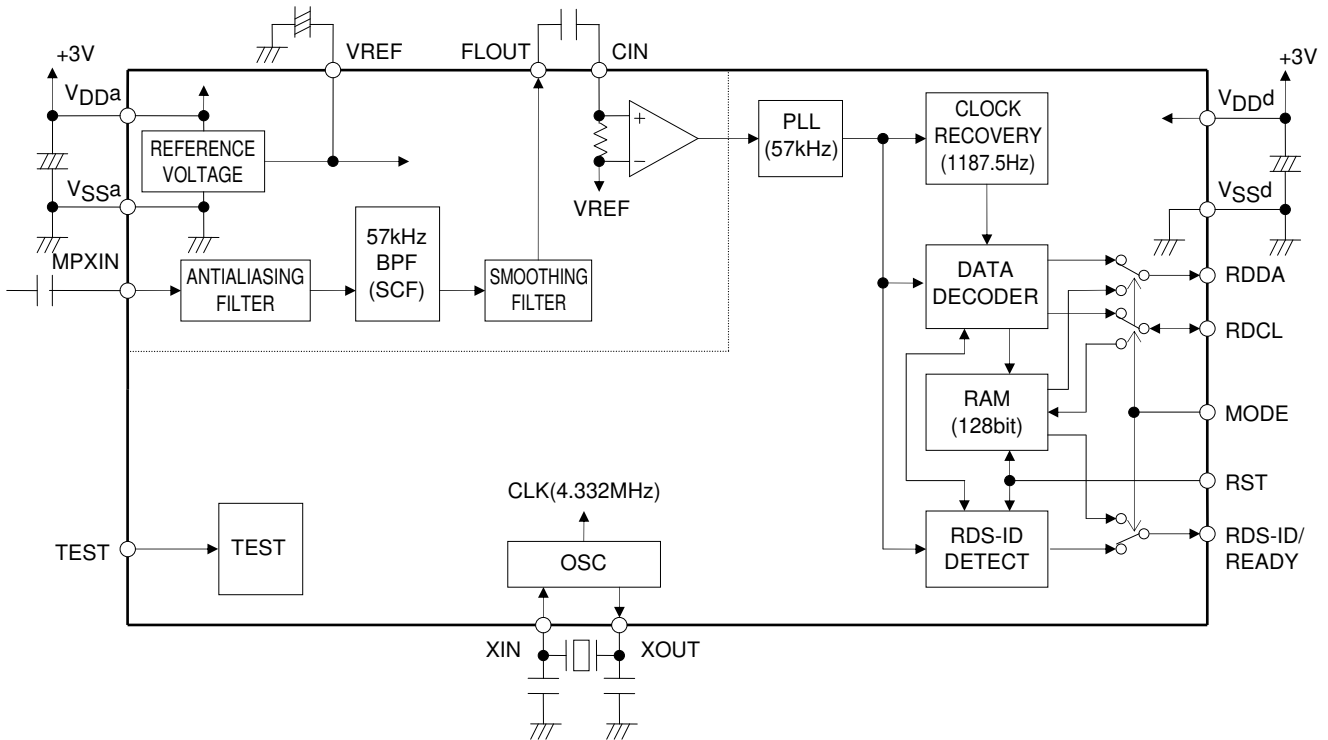

LC72725KV

Pin Descriptions

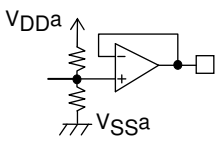
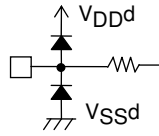
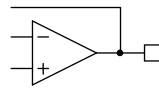
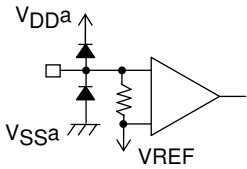
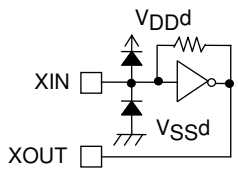
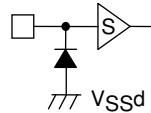
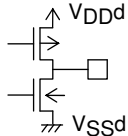
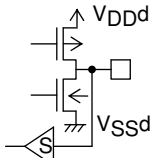
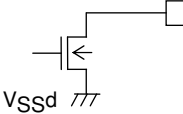
Pin No.	Pin Name	I/O	Function	Pin Circuit
3	VREF	Output	Reference voltage output ($V_{DDa}/2$)	
4	MPXIN	Input	Baseband (multiplexed) signal input	
7	FLOUT	Output	Subcarrier output (filter output)	
8	CIN	Input	Subcarrier input (comparator input)	
5	V_{DDa}	-	Analog system power supply (+3V)	
6	V_{SSa}	-	Analog system ground	
14	XOUT	Output	Crystal oscillator output (4.332MHz)	
13	XIN	Input	Crystal oscillator input (external reference signal input)	
9	TEST		Test input	
10	MODE		Read out mode (0:master, 1:slave)	
15	RST		RDS-ID/RAM reset (active high)	
2	RDDA	Output	RDS data output	
16	RDCL	I/O	RDS clock output (master mode) / RDS read out clock input (slave mode)	
1	RDS-ID/ READY	Output	RDS reliability data output (High: data with high RDS reliability Low: data with low RDS reliability) READY output (active high)	
12	V_{DDd}	-	Digital system power supply (+3V)	
11	V_{SSd}	-	Digital system ground	

LC72725KV

Input/Output Data Format

TEST	MODE	Circuit Operation Mode	RDCL Pin	RDS-ID/READY Pin
0	0	Master read out mode	Clock output	RDS-ID output
0	1	Slave read out mode	Clock input	READY output
1	0	Standby mode (crystal oscillator stopped)	-	-
1	1	IC test mode which is not available to user applications.	-	-

RST Pin	
RST = 0	Normal operation
RST = 1	RDS-ID • demodulation circuit clear + READY • memory clear (when slave mode)

RDS-ID/READY Pin	
Master mode	RDS-ID output (Active-high)
Slave mode	READY output (Active-high)

Note: RDS-ID(READY) pin is an n-channel open-drain output, and requires an external pull-up resistor to output data.

RDCL/RDDA Output Timing in Master Mode

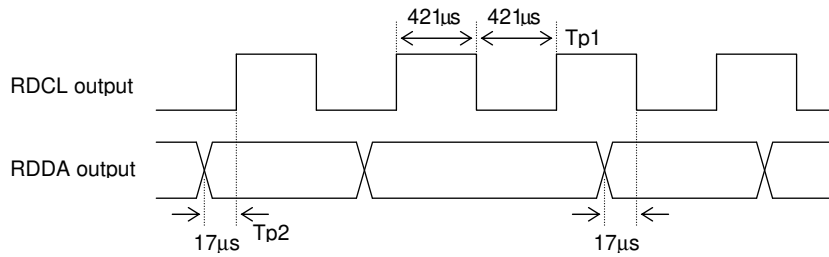

RDS-ID Output Timing

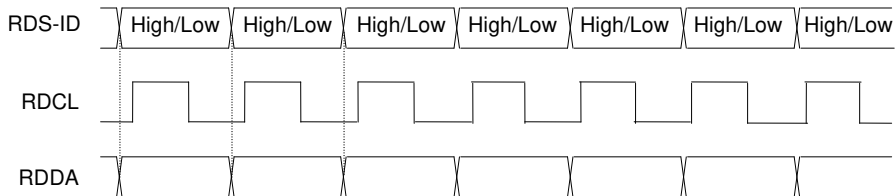

Note: RDS-ID is High: data with high RDS reliability, Low: data with low RDS reliability

RST Operation in Master Mode

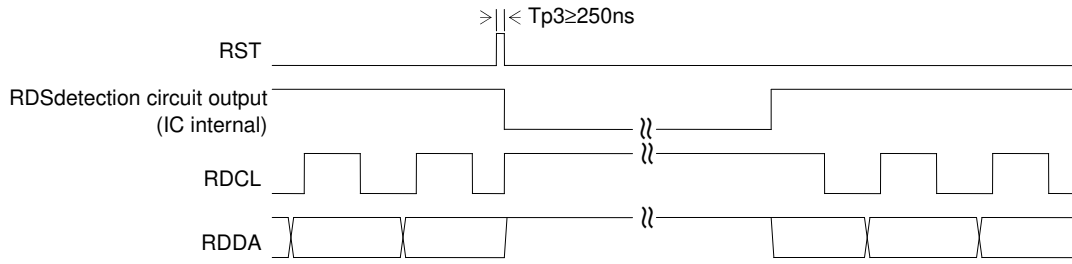

Note: RDCL and RDDA outputs keep high level after input of RST until RDS detection circuit output is detected.

RDCL Operation in Slave Mode

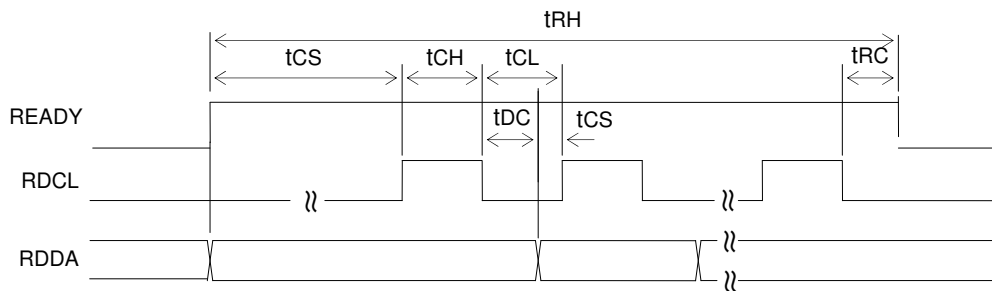

Parameter	Symbol	Pin Name	Conditions	Ratings			unit
				min	typ	max	
RDCL setup time	tCS	RDCL,RDDA		0			μs
RDCL high-level time	tCH	RDCL		0.75			μs
RDCL low-level time	tCL	RDCL		0.75			μs
Data output time	tDC	RDCL,RDDA				0.75	μs
READY output time	tRC	RDCL,READY				0.75	μs
READY high-level time	tRH	READY				107	ms

LC72725KV

- Notes: 1. RDCL input must be started after READY signal goes high. When READY signal is low, RDCL must be low level.
2. READY status must be checked after t_{RC} time from RDCL is set low. If the READY status is high, then next read cycle can be continued. If the READY status is low, next RDCL clock input must be stopped.
3. If the above condition is satisfied, RDS data (RDDA) can be read out at both rising and falling edge of RDCL.
4. READY signal goes low after the last data is read out from on-chip memory. If one RDS data is stored in the memory, READY signal goes high again.
5. When the reception channel is changed, a memory and READY reset must be applied using RST input. If a reset is not applied, reception data from the previous channel may remain in memory. If RST input is applied, reception data is not stored in memory until the first RDS-ID is detected, and READY output goes high after the first RDS-ID is detected. After the first RDS-ID is detected, reception data is stored even if RDS-ID is not detected.
6. The readout mode may be switched between master and slave modes during readout.
Applications must observe the following points to assure data continuity during this operation.
- 1) Data acquisition timing in master made
Data must be read on the falling edge of RDCL
 - 2) Timing of the switch from master mode to slave mode
After the RDCL output goes low and the RDDA data has been acquired, the application must set MODE high immediately.
Then, the microcontroller starts output by setting the RDCL signal low.
The microcontroller RDCL output must start within $840\mu s$ (t_{ms}) after RDCL went low.
In this case, if the last data read in master mode was data item n , then data starting with item $n+1$ will be written to memory.
 - 3) Timing of the switch from slave mode to master mode
After all data has been read from memory and READY has gone high, the application must then wait until READY goes low once again the next time (timing A in the figure), immediately read out one bit of data and input the RDCL clock.
Then, at the point READY goes high, the microcontroller must terminate RDCL output and then set MODE low.
The application must switch MODE to low within $840\mu s$ (t_{ms}) after READY goes low (timing A in the figure).

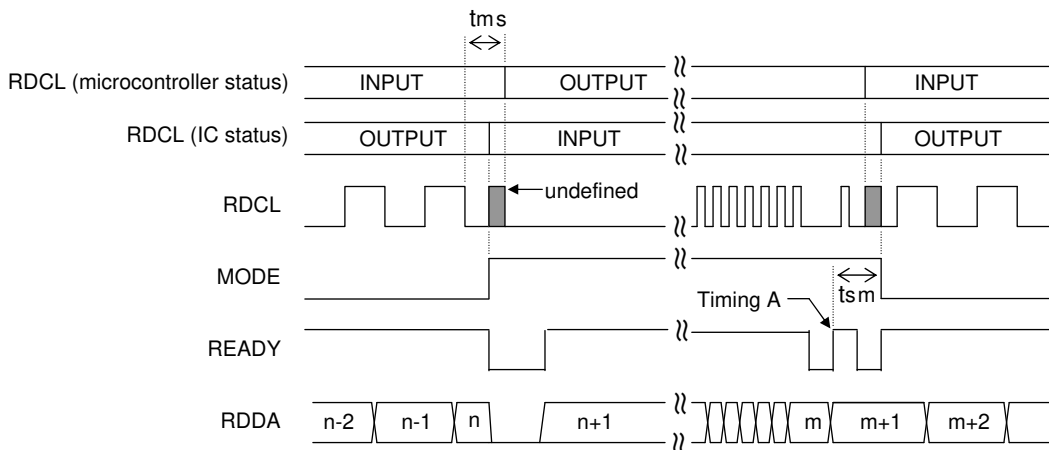

LC72725KV

Sample Application Connection Circuit (for master mode operation)

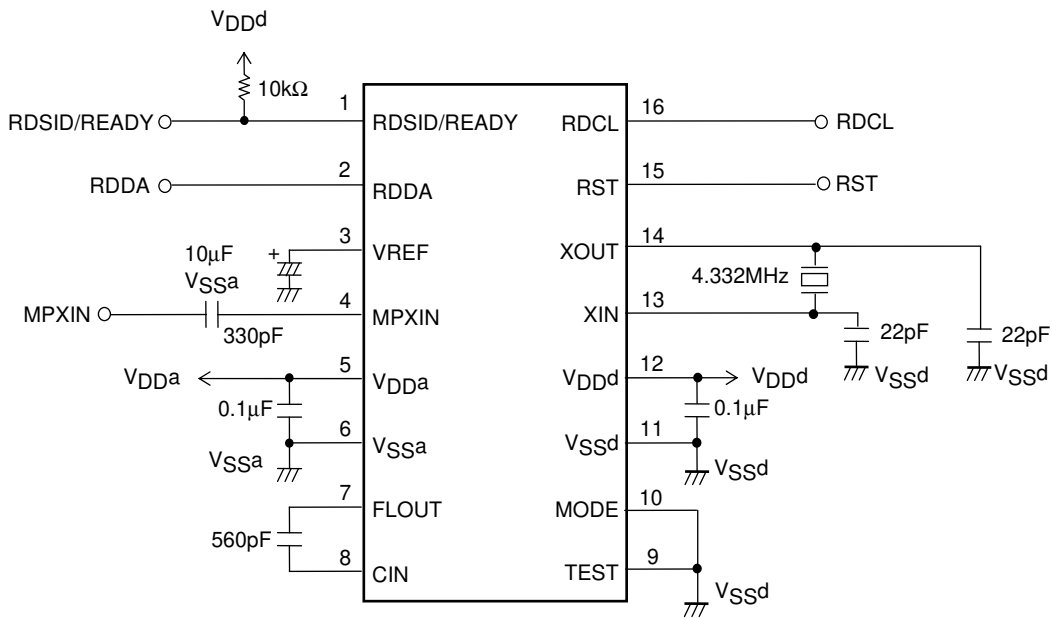

Note: If the RST pin is unused, it must be connected to ground.

ON Semiconductor and the ON logo are registered trademarks of Semiconductor Components Industries, LLC (SCILLC). SCILLC owns the rights to a number of patents, trademarks, copyrights, trade secrets, and other intellectual property. A listing of SCILLC's product/patent coverage may be accessed at www.onsemi.com/site/pdf/Patent-Marking.pdf. SCILLC reserves the right to make changes without further notice to any products herein. SCILLC makes no warranty, representation or guarantee regarding the suitability of its products for any particular purpose, nor does SCILLC assume any liability arising out of the application or use of any product or circuit, and specifically disclaims any and all liability, including without limitation special, consequential or incidental damages. "Typical" parameters which may be provided in SCILLC data sheets and/or specifications can and do vary in different applications and actual performance may vary over time. All operating parameters, including "Typicals" must be validated for each customer application by customer's technical experts. SCILLC does not convey any license under its patent rights nor the rights of others. SCILLC products are not designed, intended, or authorized for use as components in systems intended for surgical implant into the body, or other applications intended to support or sustain life, or for any other application in which the failure of the SCILLC product could create a situation where personal injury or death may occur. Should Buyer purchase or use SCILLC products for any such unintended or unauthorized application, Buyer shall indemnify and hold SCILLC and its officers, employees, subsidiaries, affiliates, and distributors harmless against all claims, costs, damages, and expenses, and reasonable attorney fees arising out of, directly or indirectly, any claim of personal injury or death associated with such unintended or unauthorized use, even if such claim alleges that SCILLC was negligent regarding the design or manufacture of the part. SCILLC is an Equal Opportunity/Affirmative Action Employer. This literature is subject to all applicable copyright laws and is not for resale in any manner.