

5301-AQM1 and 5301-AQM2 Air Quality Monitors

PM, CO₂, Temperature, RH, and TVOC

- Industry's highest concentration of up to 27,000,000 particles/ft³ @ 10% coincidence loss
- Ideal for use in research, industrial health and safety, indoor air quality, and cleanroom applications
- Industry's first Sleep Mode and Power Conservation Mode with Intelligent Battery
- The most comprehensive internal self-diagnostics of any handheld particle counter
- Real-Time Meter detects particle contamination sources with visual and audible indication
- Internet of Things (IoT) communication allows for network or cloud-based data options



The Particles Plus® 5301-AQM1 and 5301-AQM2 Remote Air Quality Monitor measures and displays particle mass concentrations for PM_{1.0}, PM_{2.5}, PM_{5.0} and PM₁₀ including temperature, relative humidity, CO₂ (and TVOC in the 5301-AQM2). This wall-mounted instrument is the most versatile remote air quality monitor available for fixed installations. The advanced power management and the industry's first sleep mode, allows for long intervals between samples over extended and unattended operations. The AQM Series can easily integrate into a building automation and facility monitoring system via Ethernet, USB or (optional) Wireless 802.11 b/g, RS485 or RS232.

The AQMs report and display 6 user-selectable particle size channels, as well as carbon dioxide (CO₂), temperature, and relative humidity. The model 5301-AQM2 includes a PID Sensor for TVOC. The instrument monitors PM_{1.0}, PM_{2.5}, PM_{5.0}, PM₁₀ and TPM. An easy-to-use Channel Management control panel allows user defined channel sizes.

Features and Benefits

- Measures 0.3 µm to 25.0 µm
- 0.1 CFM (2.83 LPM) or 1.2 LPM flow rate
- Large easy-to-use icon driven color touch screen display
- Approximates mass concentration in µg/m³ with density and refractive index corrections
- User-selectable, adjustable particle channel sizes
- 5301-AQM1 measures CO₂, temperature and humidity. The 5301-AQM2 includes TVOC.
- Stores up to 45,000 sample records
- Connect using Ethernet, USB or (optional) Wireless 802.11 b/g, RS485 or RS232
- Static or dynamic IP address (DHCP) connects to a local network or the Internet
- Seamless integration into a facility monitoring system with MODBUS RTU, ASCII or TCP
- Internet of Things JSON output allows for cloud based data storage and retrieval
- Included software permits remote operations, data management, diagnostics and more
- Displays and externally prints information with optional printer
- Internal audible alarm with user selectable thresholds for all environmental parameters
- Easy configuration and transferable from instrument to instrument
- User friendly field calibration with single or dual point offsets for all sensors
- Remote diagnostics allows for remote service investigation through the Internet
- User-selectable channel sizes
- Long life laser diode technology
- Lightweight high-impact injection molded plastic enclosure
- 2 year limited warranty. Extended warranties available.

Specifications

Model	5301-AQM1 and 5301-AQM2
Size Range	0.3 to 25 μm
Size Channels	Factory calibrated at 0.3, 0.5, 1.0, 2.5, 5.0, 10.0 μm variable binning
Flow rates / Accuracy	0.1 CFM (2.83 LPM) / $\pm 3\%$ or 1.2 LPM $\pm 3\%$
Aerosol Concentration Range	0.01 to 20,000 $\mu\text{g}/\text{m}^3$
Light Source	Long life laser diode
Resolution	0.00003 $\mu\text{g}/\text{m}^3$
Zero Stability	No appreciable drift
Count Modes	Real-Time Meter and graph, cumulative/differential count/ m^3 and count/ ft^3 , and mass concentration (PM)
Log Interval	Minimum 1 second with no hold time, maximum 99 hours
Calibration	NIST traceable
Display	4.3" (10.9 cm) WQVGA (480x272) color touch screen
Printer	(Optional) External thermal printer available
Vacuum Source	Internal pump with automatic flow control
Filtered Exhaust	Internal HEPA filter
Number of Channels	6
Custom Size Channels	Calibration for custom size channels available
Audible Alarm	Adjustable built-in alarm
Communication Modes	Ethernet, USB. (Optional) Wireless 802.11 b/g, RS485 or RS232.
Environmental Sensors	Includes NDIR CO ₂ (0-5000 ppm, resolution 1 ppm, accuracy $\pm 1\%$ FS, Response rate 20 seconds), temperature and relative humidity probe 32° to 122°F (0° to 50°C) $\pm 1^\circ\text{F}$ (0.5°C), 15-90% $\pm 2\%$ RH
5301-AQM1	
Environmental Sensors	Includes all sensors in the 5301-AQM1 and TVOC PID (standard on the 5301-AQM2), 0-50 ppm / minimum detection level 5 ppb, accuracy $\pm 1.5\%$, Response rate <3 seconds
5301-AQM2	
Alarm	Alarms on counts for all particle sizes, low battery, sensor failure, environmental sensors and flow
Standards	ISO 21501-4 and JIS B9921
Instrument Calibration	Recommended minimum once per year. Gases, temperature and humidity sensors field calibratable.
External Surface	Lightweight high-impact injection molded plastic enclosure
Dimensions (L x W x H)	5.22" x 2.25" x 9.13" (13.3 cm x 5.7 cm x 23.2 cm) includes barb fittings
Weight	4 lb (1.8 kg)
Accessories	Operating manual and IMS software on USB flash drive, isokinetic probe, temperature relative humidity sensor, purge filter, battery, data download software, USB cable, power supply and cable
Optional Accessories	Printed manual, carrying case, spare battery, external battery charger, external printer and isokinetic probes, barbed fittings, IMS-RT monitoring system
Data Storage	45,000 sample records (rotating buffer) including particle count data, environmental data, locations, annotations, and times. Scrollable on screen or printout.times. Scrollable on screen or printout
Sample Time	1 second to 99 hours
Power	110 to 240 VAC 50/60 Hz universal in-line power supply
Operating Conditions	41° to 104°F (5° to 40°C) / 20% to 95% non-condensing
Storage Conditions	32° to 122°F (0° to 50°C) / Up to 98% non-condensing
Warranty	2 Years. Extended warranties available.

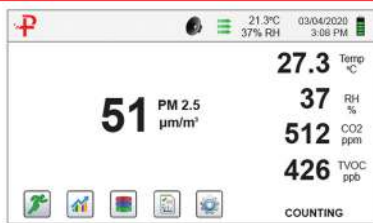

Configurable Environmental Sensor Display

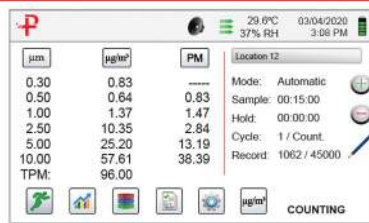

Simultaneous Display of Multiple PM Sizes

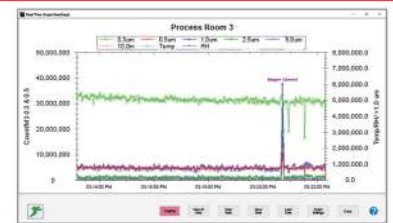

Control and Manage Remotely with IMS

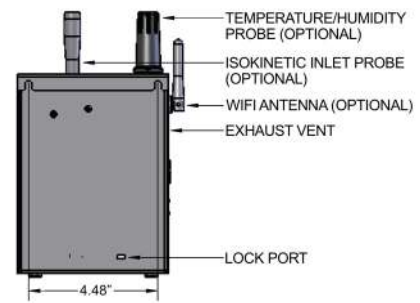
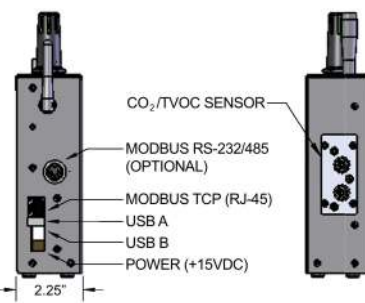
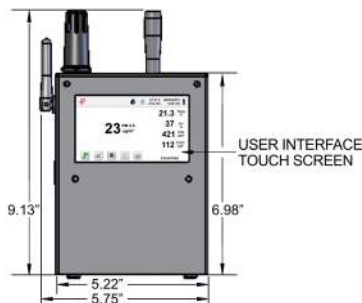

PAT. <https://particlepatents.com/> Additional Patents Pending.
 Particles Plus, Inc. reserves the right to change specifications without notice.
 Contact hello@particlesplus.com or your local distributor for more details.
 Particles Plus and the Particles Plus logo are trademarks of Particles Plus, Inc.
 ©2022 Particles Plus, Inc. All rights reserved.

REV 20230331-8501-AQM1/5301-AQM2



31 Tosca Drive
 Stoughton, MA 02072 U.S.A.
 +1-781-341-6898
www.particlesplus.com