

# LCD Backlight Lamp Driver with Contrast

## GENERAL DESCRIPTION

The ML4876 is an ideal solution for driving small cold cathode fluorescent tubes (CCFL) used in liquid crystal display (LCD) backlight applications. It provides the dimming ballast control and the contrast control for the LCD display.

By utilizing differential drive the ML4876 can deliver the same light output with significantly less input power compared to existing single ended drive schemes. Improvements as high as 30% can be realized when using low power lamps and advanced LCD screen housings. This increased light output is achieved because the differential drive configuration is much less sensitive, and therefore less power is wasted in the capacitive parasitics that exist in the backlight housing. An additional benefit of this configuration is an even distribution of light.

The ML4876 is optimized for portable applications where high efficiency is critical to maximize battery life. The high efficiency is achieved by a resonant scheme with zero voltage switching.

## FEATURES

- Backlight lamp driver with differential drive
- Up to 30% lower power for same light output
- Low standby current (< 10µA)
- Improved efficiency (≈95%)
- Allows all N-channel MOSFET drive
- Low switching losses
- Resonant threshold detection
- Buck regulator uses synchronous rectification

\* THIS PART IS END OF LIFE AS OF JULY 1, 2000

## BLOCK DIAGRAM

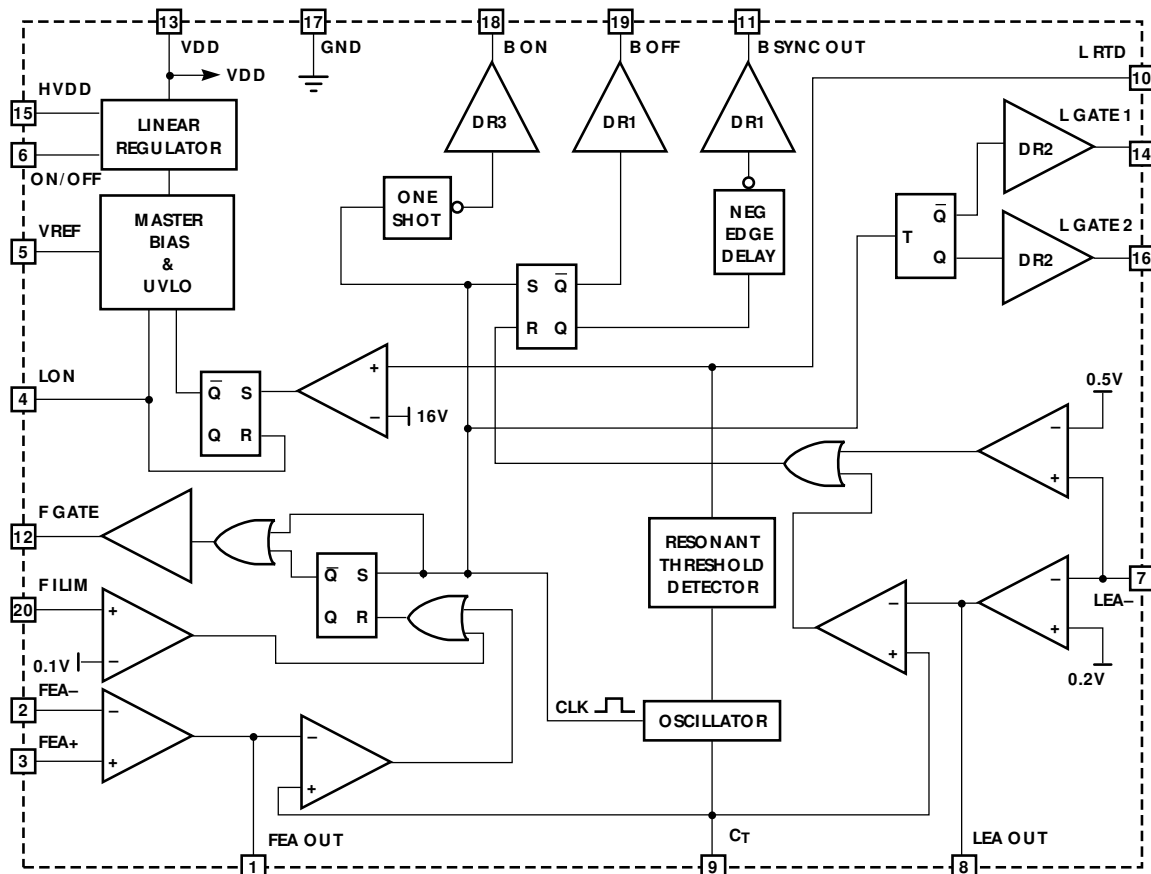

## PIN CONFIGURATION

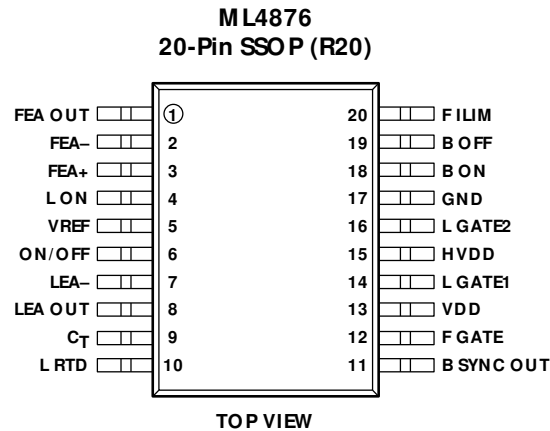

## PIN DESCRIPTION

PIN	NAME	DESCRIPTION	PIN	NAME	DESCRIPTION
1	FEA OUT	Output of flyback (contrast) error amplifier	11	B SYNC OUT	Output of MOSFET driver. Connects to gate of synchronous FET catch diode.
2	FEA-	Negative input of flyback (contrast) error amplifier	12	F GATE	Connects to gate of MOSFET in primary side of contrast control
3	FEA+	Positive input of flyback (contrast) error amplifier	13	VDD	Output of linear regulator. Positive power for IC.
4	L ON	Logic input. A "0" on this pin disables the lamp driver section only	14	L GATE1	Output of MOSFET driver. Connection to gate of one side of inverter FET drive pair
5	VREF	Voltage reference output	15	HVDD	Battery power input to linear regulator
6	ON/OFF	Logic input. A "0" on this pin disables the linear regulator	16	L GATE2	Output of MOSFET driver. Connection to gate of one side of inverter FET drive pair
7	LEA-	Negative input for lamp error amplifier	17	GND	Ground
8	LEAOUT	Output of lamp error amplifier	18	B ON	Connection to primary side of gate pulse transformer
9	C <sub>T</sub>	Oscillator timing capacitor	19	B OFF	Output of MOSFET driver. Connection to gate of FET that disables the input power.
10	L RTD	Input to resonant threshold detector	20	F ILIM	Input to current limit comparator

## ABSOLUTE MAXIMUM RATINGS

Absolute maximum ratings are those values beyond which the device could be permanently damaged. Absolute maximum ratings are stress ratings only and functional device operation is not implied.

Supply Current ( $I_{CC}$ ) .....	75mA
Output Current, Source or Sink .....	250mA
Voltage on HVDD .....	20V
Current into L RTD .....	$\pm 10$ mA
Transient Voltage on B ON .....	9V

Voltage on Any Other Pin .....	-0.3V to VDD +0.3V
Junction Temperature .....	150°C
Storage Temperature Range .....	-65°C to 150°C
Lead Temperature (Soldering 10 sec.) .....	260°C
Thermal Resistance ( $q_{jA}$ ) Plastic SSOP .....	100°C/W

## OPERATING CONDITIONS

Temperature Range	
ML4876C .....	0°C to 70°C
ML4876E .....	-20°C to 70°C

## ELECTRICAL CHARACTERISTICS

Unless otherwise specified, VDD = 5V  $\pm 5\%$ ,  $C_T = 47$ pF,  $T_A$  = Operating Temperature Range (Note 1)

SYMBOL	PARAMETER	CONDITIONS	MIN	TYP	MAX	UNITS
--------	-----------	------------	-----	-----	-----	-------

### CURRENT REGULATOR

#### Error Amplifier

	Open Loop Gain		60	70		dB
	Bias Point	Closed loop	0.18	0.2	0.22	V
	Output High	$I_{LOAD} = 5\mu A$	2.8	3.0		V
	Output Low	$I_{LOAD} = 25\mu A$		0.4	0.7	V
	Bandwidth (-3dB)			1		MHz
	Input Voltage Range		-0.3	0.2	VREF	V
	Input Bias Current			50	100	nA

#### Current Limit Comparator

	Current Threshold		450	500	550	mV
	Input Bias Current	$V_{LILIM} = 0.1V$		50	100	nA
	Propagation Delay	(Note 2)		30		ns

#### Output Drivers

	Output High - B SYNC OUT, B OFF	VDD = 5V, $I_{LOAD} = 12mA$	4.625	4.8		V
	Output Low - B SYNC OUT, B OFF	$I_{LOAD} = 12mA$		0.2	0.375	V
	Rise & Fall time - B SYNC OUT, B OFF	$C_{LOAD} = 100pF$		20	50	ns
	Output High - B ON	VDD = 5V, $I_{LOAD} = 12mA$	4.625	4.8		V
	Output Low - B ON	$I_{LOAD} = 50mA$		0.2	0.375	V
	Fall Time - B ON	$C_{LOAD} = 2400pF$ (Note 2)		45	80	ns
	ONE SHOT Pulse Width		100	150	200	ns
	DELAY TIMER Delay Time		20	35	55	ns

### FLYBACKREGULATOR

#### Error Amplifier

	Open Loop Gain		60	70		dB
	Offset Voltage		-15		15	mV
	Output High	$I_{LOAD} = 5\mu A$	2.8	3.0		V
	Output Low	$I_{LOAD} = 25\mu A$		0.4	0.7	V

# ML4876

## ELECTRICAL CHARACTERISTICS (Continued)

SYMBOL	PARAMETER	CONDITIONS	MIN	TYP	MAX	UNITS
--------	-----------	------------	-----	-----	-----	-------

### FLYBACK REGULATOR (Continued)

#### Current Limit Comparator

	Threshold		70	100	130	mV
	Input Bias Current	$V_{LILIM} = 0.1V$		50	100	nA
	Propagation Delay			125	250	ns

#### Output Drivers

	Output High - F Gate	$V_{DD} = 5V, I_{LOAD} = 12mA$	4.625	4.8		V
	Output Low - F Gate	$I_{LOAD} = 50mA$		0.2	0.375	V
	Rise & Fall Time	$C_{LOAD} = 1000pF$		20	50	ns

### HIGH VOLTAGE INVERTER

#### Oscillator

	Nominal Frequency		59	70	81	kHz
	Discharge Current	$V_{CT} = 2V$	500	700	900	$\mu A$
	Peak Voltage		2.3	2.5	2.7	V
	Valley Voltage		0.8	1	1.2	V
	Output Drivers					
	Output High - L GATE 1, 2	$V_{DD} = 5V, I_{LOAD} = 12mA$	4.625	4.8		V
	Output Low - L GATE 1, 2	$I_{LOAD} = 50mA$		0.2	0.375	V
	Rise & Fall Time - L GATE 1, 2	$C_{LOAD} = 1000pF$		20	50	ns

#### Resonant threshold Detector

	Threshold		0.75	1.1	1.45	V
	Hysteresis		250	500	750	mV

#### Lamp Out Detect

	Threshold		16	18	20	V
--	-----------	--	----	----	----	---

#### Under Voltage Detector

	Start Up Threshold		3.8	4.1	4.4	V
	Hysteresis		150	300	450	mV

#### Logic Interface (On/Off, L ON)

	$V_{IH}$		2.6			V
	$V_{IL}$				0.5	V
	Input Bias Current	$V_I = 3V$		10	25	$\mu A$

#### Linear Regulator

	Regulator Voltage (VDD)	$HV_{DD} = 12V$	4.75	5.0	5.35	V
	Regulator Source Current	External to device		10		mA
	Drop Out Voltage	$I_{HV_{DD}} = 1mA$		30	90	mV
	Drop Out Voltage	$I_{HV_{DD}} = 5mA$		125	275	mA
	$HV_{DD}$ Input Voltage Range		5		18	V

**ELECTRICAL CHARACTERISTICS** (Continued)

SYMBOL	PARAMETER	CONDITIONS	MIN	TYP	MAX	UNITS
<b>SUPPLY</b>						
	VDD Supply Current (No Load)	On/Off = 3V, L <sub>ON</sub> = 3V		0.45	0.6	mA
	VDD Supply Current	On/Off = 3V, L <sub>ON</sub> = 0V		200	350	μA
	VDD Supply Current	On/Off = "0", HVDD = 12V			10	μA
	VREF Output Voltage	T <sub>A</sub> = 25°C	2.47	2.5	2.53	V
	VREF Load Regulation	I <sub>VREF</sub> = 25μA		10	20	mV
	VREF Line Regulation			20	30	mV
	VREF Line, Load, Temp		2.465	2.5	2.535	V

**Note 1:** Limits are guaranteed by 100% testing, sampling, or correlation with worst case test conditions.

**Note 2:** Actual load is 1200pF. The 2:1 transformer reflects an effective 2400pF.

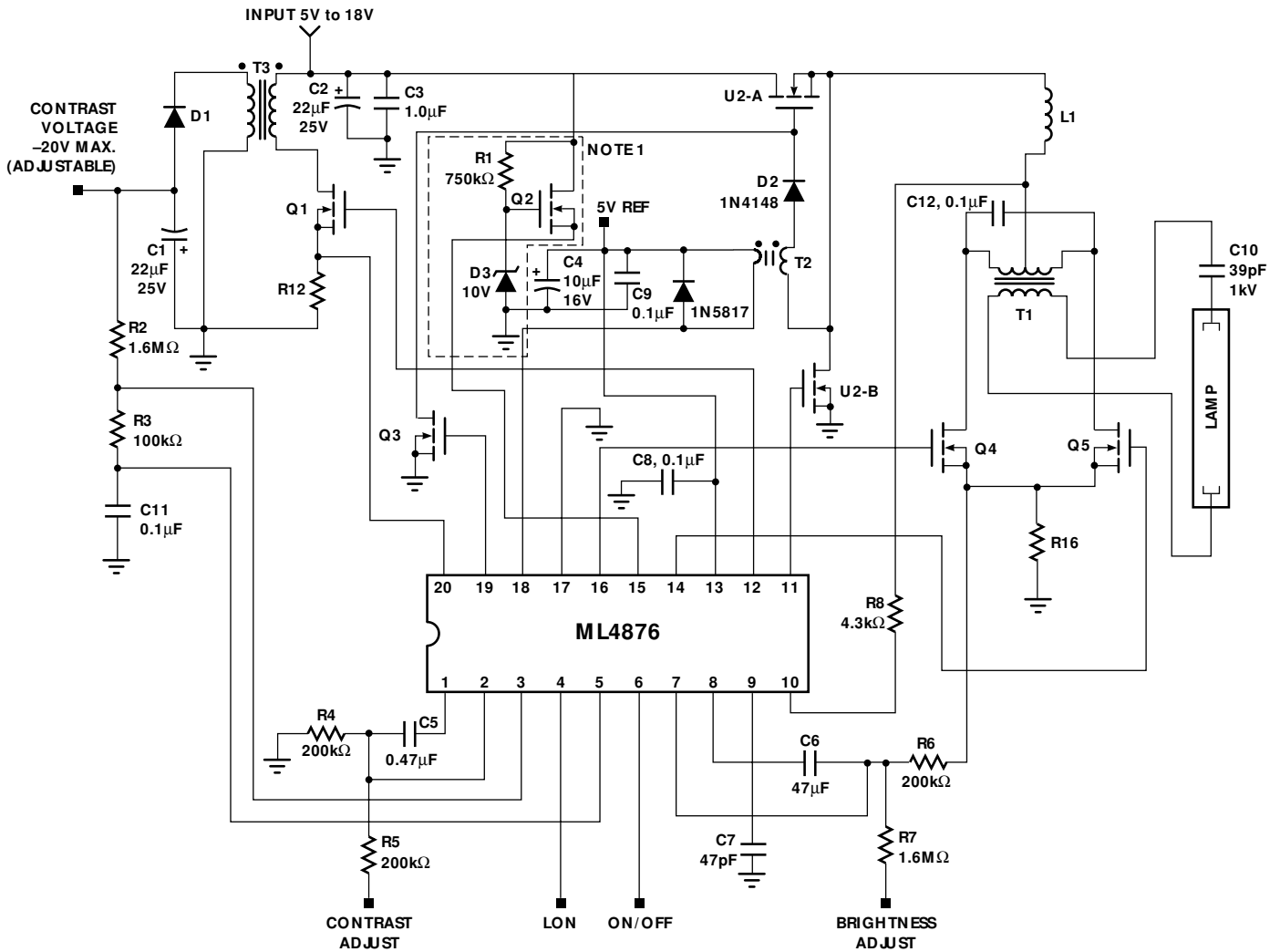

Figure 1. ML4876 Typical Application Schematic

## FUNCTIONAL DESCRIPTION

The ML4876 consists of a PWM regulator, a lamp driver/inverter, a linear regulator, a flyback regulator, and control circuits. This IC, in conjunction with external components, converts a DC battery voltage into the high voltage and high frequency ac signal required to start and drive miniature cold cathode fluorescent lamps. In addition it generates the DC voltage for the contrast requirements of LCD screens. A typical application circuit is shown in Figure 1. Please refer to Application Note 32 for detailed application information beyond what is presented here.

**Note:** Please read the Power Sequencing section below prior to using the ML4876.

### LAMP DRIVER

The lamp driver, sometimes referred to as a lamp inverter, is comprised of a PWM regulator and a Royer type inverter circuit to drive the lamp. The PWM regulator, in a buck configuration, controls the magnitude of the lamp current to provide the dimming capability. Figure 2 shows a simplified circuit to more easily illustrate the operation of the circuit.

Due to the presence of the buck inductor, L1, the circuit shown in Figure 2 is essentially a current fed parallel loaded resonant circuit.  $L_m$  is the primary inductance of the output transformer, T1, which tunes with the resonant capacitor  $C_R$  to set the resonant frequency of the inverter. The oscillator frequency is always set lower than the natural resonant frequency to ensure synchronization. The current source IC models the current through the buck inductor L1.

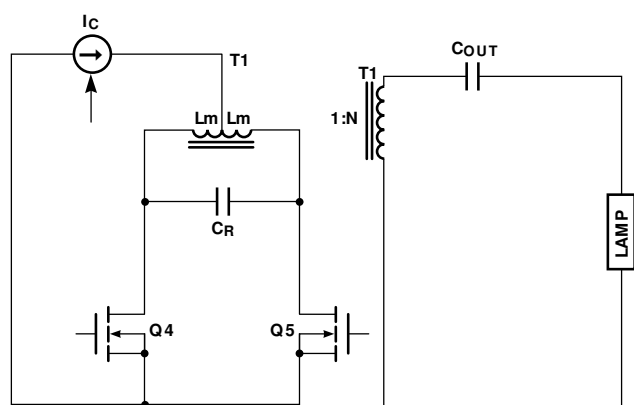

Figure 2. Simplified Lamp Driver Circuit

The MOSFETs (Q4 and Q5) are alternately turned on with a constant 50% duty cycle signal (L GATE1, L GATE2) at one-half the frequency of the oscillator. In this way each transistor pulses, or excites, the resonant tank on each half cycle. The combination of these two signals appear across the primary winding of the output transformer as a sinusoidal waveform. This voltage is multiplied by the step-up turns ratio of the output transformer and impressed across the lamp.

The output transitions are controlled by feedback through the L RTD pin by sensing the voltage at the center tap of the output transformer. Each time this signal reaches the minimum resonant threshold detection point an internal clock pulse is generated to keep the system synchronized. Figure 3 shows some of these representative waveforms at the important nodes of the circuit.

The PWM regulator is comprised of a MOSFET (U2-A), inductor L1, and the gate control and drive circuitry as shown in Figure 1. A signal with a constant pulse width of 150ns is applied to the primary of the 2:1 pulse transformer T2, rectified by diode D2, and used to charge the gate capacitance of U2-A, thereby turning it on. The turn off is controlled by discharging this capacitance through MOSFET U2-B. The pulse width of the signal on the gate of U2-B (B OFF) varies according to the amplitude of the feedback signal on LEA-, which is proportional to the AC current flowing in the lamp. This feedback signal is developed by monitoring the current through resistor R6 in the common source connection of the inverter MOSFETs (Q4 and Q5). The lamp current, and therefore brightness, is adjusted by varying the voltage applied to R7 at the brightness adjust control point. Increasing this voltage decreases the brightness.

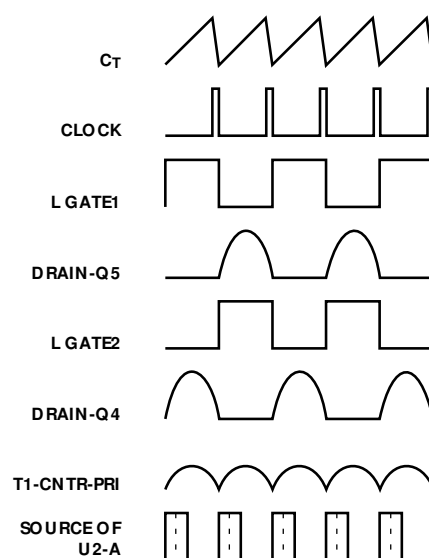

Figure 3. Operating Waveforms of the Lamp Driver Section

## FUNCTIONAL DESCRIPTION (Continued)

### CONTRAST CONTROL GENERATOR

The contrast voltage generator is a separate regulator in a flyback configuration. In conjunction with the external transformer (T3), MOSFET (Q1), diode (D1), and assorted capacitors and resistors, it provides an adjustable DC output contrast voltage necessary to drive LCD screens. The voltage is adjusted by controlling the voltage applied to R5 at the contrast adjustment point.

The contrast voltage can be made either positive or negative simply by changing the connection of the external components. The schematic shown in Figure 1 is connected for a negative voltage. Please refer to Application Note 32 for the circuit connection for a positive output voltage.

### OSCILLATOR

The frequency of the oscillator in the ML4876 is set by selecting the value of  $C_T$ .

Figure 4 shows the oscillator frequency versus the value of  $C_T$ . This nomograph may be used to select the appropriate value of  $C_T$  to achieve the desired oscillator frequency.

### LINEAR REGULATOR

A linear voltage regulator is provided to power the low voltage and low current control circuitry on the ML4876. This is typically used when there is no separate 5V supply available at the inverter board. For operation up to 18V the linear regulator is used by connecting HVDD to the input battery voltage. For operation over 18V, a MOSFET and a resistor (Q2 and R1, Figure 1) are connected as shown. The MOSFET is required to stand off the high voltage.

### LAMP OUT DETECT

In those cases when there is no lamp connected, or the connection is faulty, the output voltage of the lamp driver circuit will tend to rise to a high level in an attempt to start the nonexistent lamp. The lamp out detect circuit on the ML4876 will detect this condition by sensing the center tap voltage on the primary of the output transformer (T1) on the L RTD pin. When this voltage exceeds 16V, an internal latch is set and the lamp driver goes into a shutdown mode. The logic control pin L ON must be cycled low, then high to reset the latch and return the lamp driver to the normal state.

### LOGIC CONTROL

The ML4876 is controlled by a two logic inputs, L ON and ON/OFF. A logic level high on the L ON pin enables just the lamp driver. A logic zero on the L ON pin disable the lamp driver only. A logic level high on the ON/OFF pin enable the complete circuit. A logic level low on the ON/OFF pin puts the circuit into a very low power state.

### POWER SEQUENCING

It is important to observe correct power and logic input sequencing when powering up the ML4876. The following procedure must be observed to avoid damaging the device.

1. Apply the battery power to HVDD
2. Apply the VDD voltage (if HVDD is not used). With HVDD connected this voltage is supplied by the internal regulator on the ML4876.
3. Apply a logic high to the ON/OFF input. This will enable the internal linear regulator to ensure the VDD supply is on (when HVDD is used).
4. Apply a logic high to the L ON input.

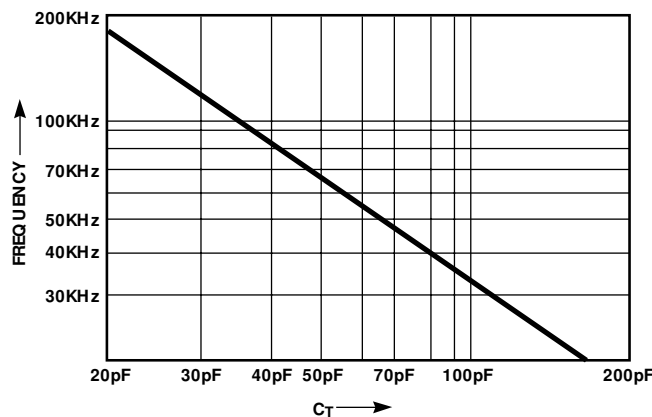
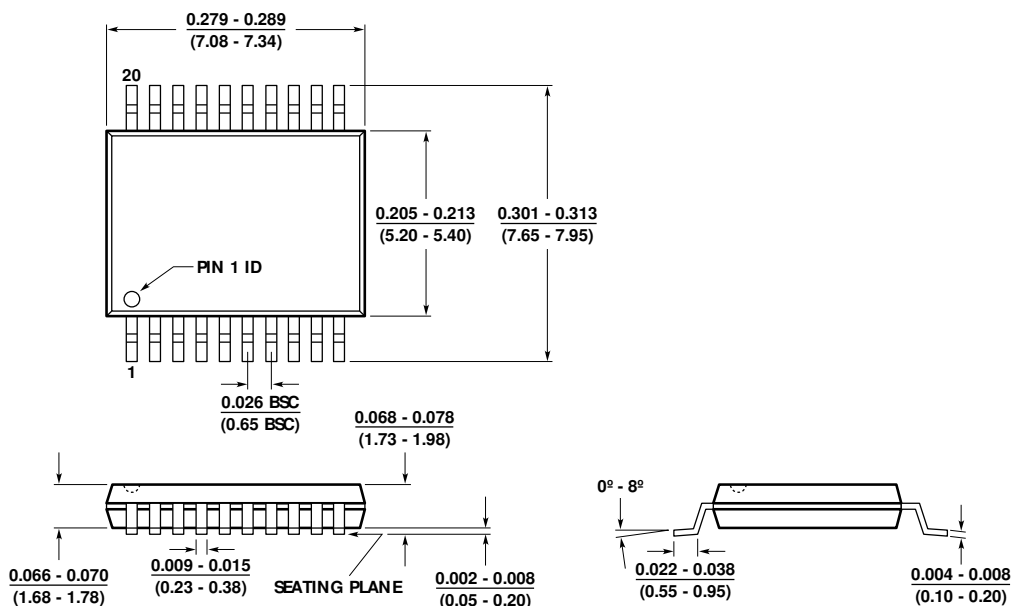

Figure 4. Frequency vs.  $C_T$



## PHYSICAL DIMENSIONS inches (millimeters)

Package: R20  
20-Pin SSOP



## ORDERING INFORMATION

PART NUMBER	TEMPERATURE RANGE	PACKAGE
ML4876CR (END OF LIFE)	0°C to 70°C	20-Pin Molded SSOP (R20)
ML4876ER (OBSOLETE)	-20°C to 70°C	20-Pin Molded SSOP (R20)

### DISCLAIMER

FAIRCHILD SEMICONDUCTOR RESERVES THE RIGHT TO MAKE CHANGES WITHOUT FURTHER NOTICE TO ANY PRODUCTS HEREIN TO IMPROVE RELIABILITY, FUNCTION OR DESIGN. FAIRCHILD DOES NOT ASSUME ANY LIABILITY ARISING OUT OF THE APPLICATION OR USE OF ANY PRODUCT OR CIRCUIT DESCRIBED HEREIN; NEITHER DOES IT CONVEY ANY LICENSE UNDER ITS PATENT RIGHTS, NOR THE RIGHTS OF OTHERS.

### LIFE SUPPORT POLICY

FAIRCHILD'S PRODUCTS ARE NOT AUTHORIZED FOR USE AS CRITICAL COMPONENTS IN LIFE SUPPORT DEVICES OR SYSTEMS WITHOUT THE EXPRESS WRITTEN APPROVAL OF THE PRESIDENT OF FAIRCHILD SEMICONDUCTOR CORPORATION. As used herein:

- Life support devices or systems are devices or systems which, (a) are intended for surgical implant into the body, or (b) support or sustain life, and (c) whose failure to perform when properly used in accordance with instructions for use provided in the labeling, can be reasonably expected to result in a significant injury of the user.
- A critical component in any component of a life support device or system whose failure to perform can be reasonably expected to cause the failure of the life support device or system, or to affect its safety or effectiveness.