

2.5 A bipolar stepper motor drive module

Features

- Wide supply voltage range
- Full/half step drive capability
- Logic signals TTL/CMOS compatible
- Programmable motor phase current and chopper frequency
- Selectable slow/fast current decay
- Synchronization for multi-motor applications
- Remote shutdown
- Home position indication

Description

The SPMD250STP is a drive module that directly interface a microprocessor to a two phase, bipolar, permanent magnet stepper motors.

The phase current is chopper controlled, and the internal phase sequence generation reduces the burden of the controller and it simplifies software development. The SPMD250STP has Power MOSFET outputs to significantly reduce both commutation and conduction losses. A further benefit offered by the SPMD250STP is the complete protection of the outputs against any type of shorts.

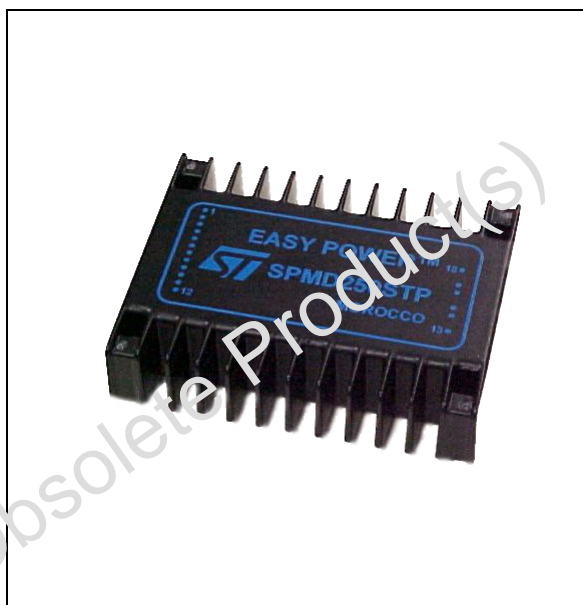

Table 1. Device summary

Order code
SPMD250STP

Contents

1	Electrical data	3
1.1	Absolute maximum ratings	3
2	Electrical characteristics	4
3	Signal timing and block diagram	5
4	Pin connection	7
5	Bipolar stepper motor basics	9
5.1	One-phase-on or wave drive	9
5.2	Two-phase-on or normal drive	9
5.3	Half step drive	10
6	Phase sequence generation inside the device	12
7	RESET, ENABLE and HOME signals	14
8	Motor current regulation	14
9	User notes	16
9.1	Supply voltage	16
9.2	Case grounding	16
9.3	Thermal characteristics	16
9.4	Supply line impedance	16
9.5	Module protections	17
9.6	Motor connection	17
9.7	Unused inputs	17
9.8	Phase current programming	17
9.9	Chopper frequency programming	18
10	Multi modules application	20
11	Thermal operating conditions	22

12	Package mechanical data	25
13	Revision history	27

Obsolete Product(s) - Obsolete Product(s)

1 Electrical data

1.1 Absolute maximum ratings

Table 2. Absolute maximum ratings

Symbol	Parameter	Value	Unit
V_S	DC supply voltage (pin 18)	42	V
V_{SS}	DC logic supply voltage (pin 12)	7	V
Tstg	Storage temperature range	- 40 to +105	°C
Tcop	Operating case temperature range	- 40 to +85	°C

2 Electrical characteristics

$T_A = 25\text{ °C}$ and $V_S = 24\text{ V}$ unless otherwise specified

Table 3. Electrical characteristics

Symbol	Parameter	Test conditions	Value			Unit
			Min	Typ	Max	
Vs	DC supply voltage		12		40	V
Vss	DC logic supply voltage			5		V
Is	Quiescent supply current	Pin 18			20	mA
Iss	Quiescent logic supply current	Pin 12 Vss = 5 V		60		mA
Vi	Input voltage	Pin 3,4,6,7,10,11	Low		0.8	V
			High	2	Vss	V
Ii	Input current	Pin 3,4,6,7,10,11	Vi = Low	0.6		mA
			Vi = High	10		μA
Vsat	Source/sink saturation voltage	Pin 14,15,16,17			1.8	V
Io	Phase current				2.5	A
IoL	Current limit intervention		5			A
fc	Chopper frequency			17		kHz
tclk	Step ckl width	Pin 6 (<i>Figure 1 on page 6</i>)	0.5			μs
ts	Set up time	"	1			μs
th	Hold time	"	1			μs
tr	Reset width	"	1			μs
trclk	Reset to clock set up time	"	1			μs

3 Signal timing and block diagram

Figure 1. Signals timing

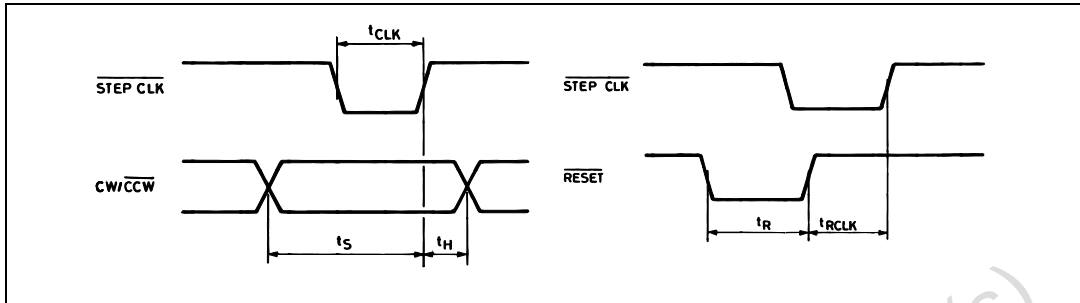

Figure 2. Block diagram

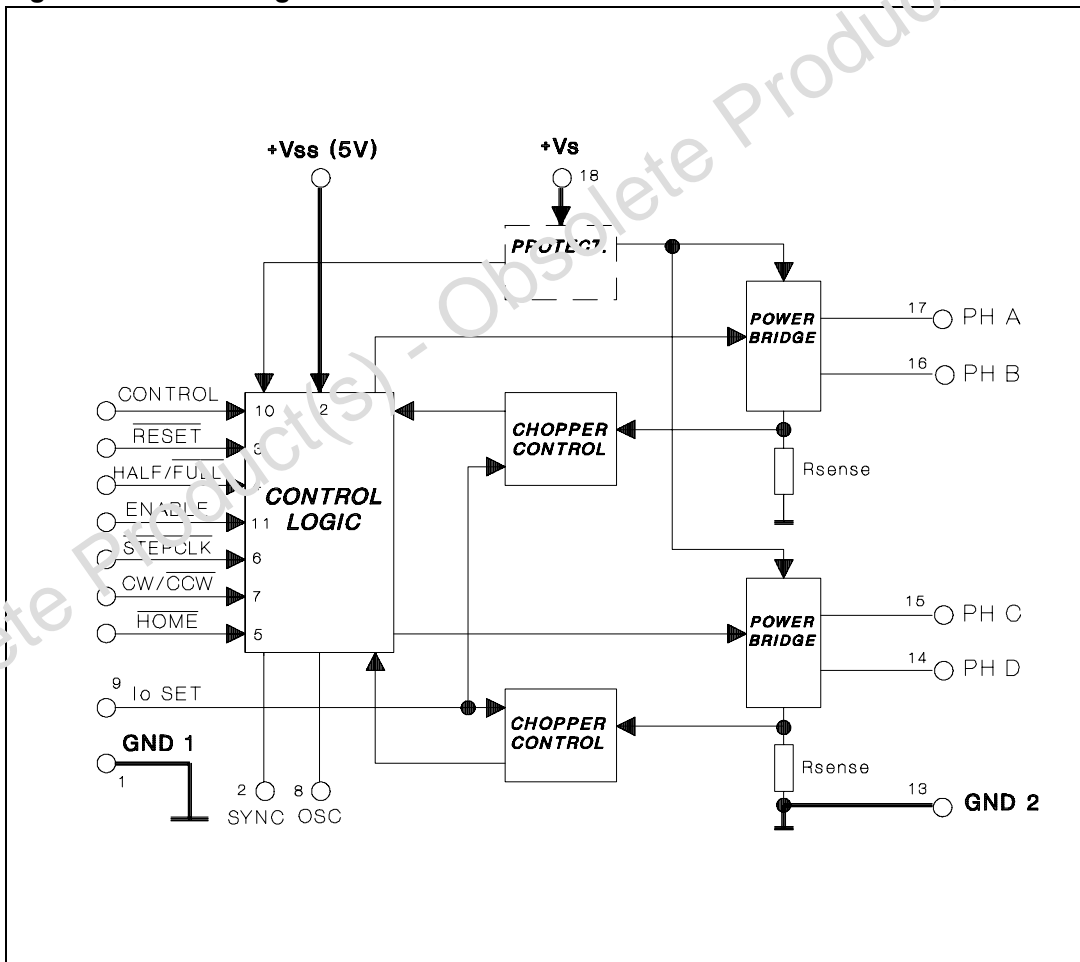
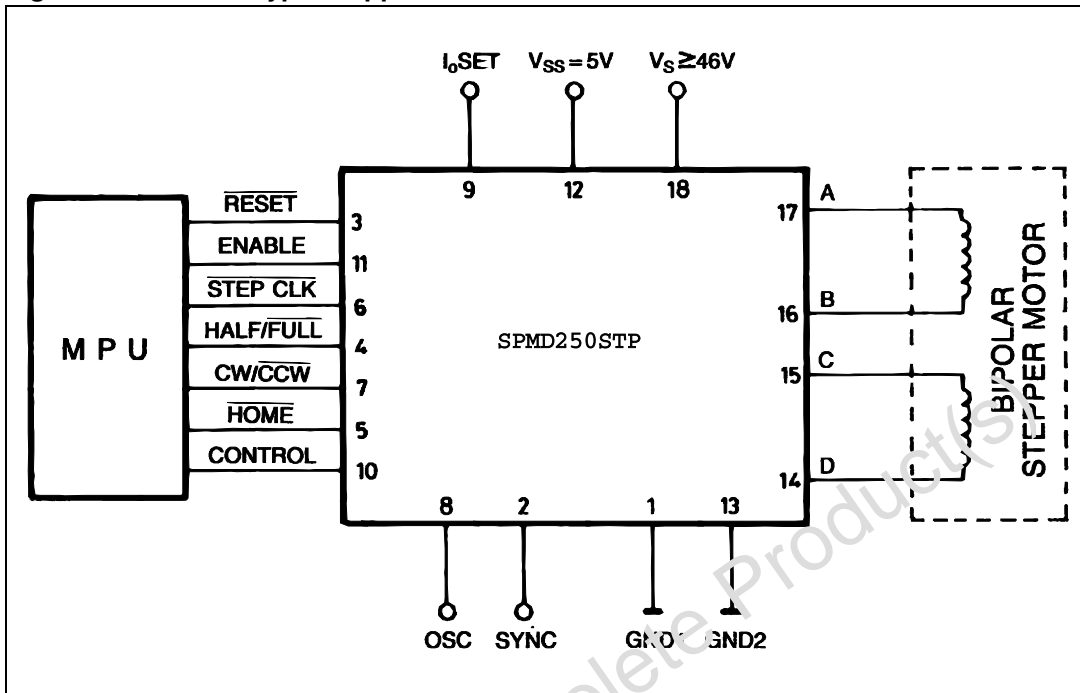

Figure 3. Module typical application



Obsolete Product(s) - Obsolete Product(s)

4 Pin connection

Figure 4. Connection diagram (top view)

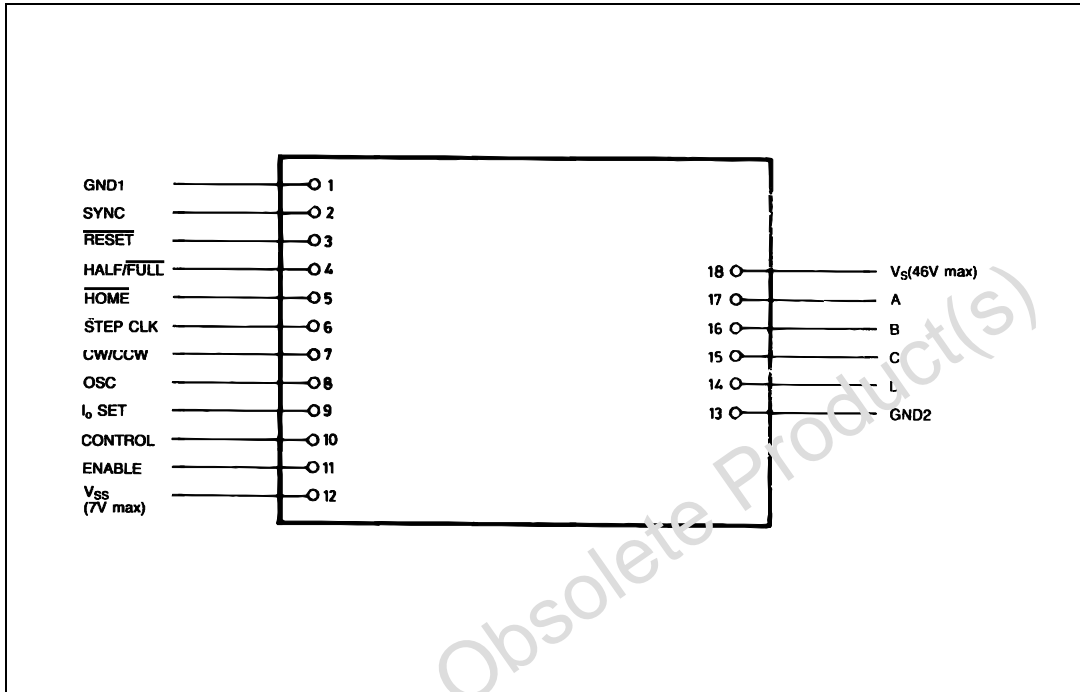

Table 4. Pin description

N°	Name	Function
1	GND1	Return path for the logic signals and 5 V supply.
2	Sync	Chopper oscillator output. Several modules can be synchronized by connecting together all Sync pins. This pin can be used as the input for an external clock source.
3	Reset	Asynchronous reset input. An active low pulse on this input preset the internal logic to the initial state (ABCD = 0101).
4	Half/Full	Half/full step selection input. When high or unconnected the half step operation is selected.
5	Home	When high, this output indicates that the internal counter is in its initial state (ABCD = 0101). This signal may be used in conjunction with a mechanical switch to ground or with open collector output of an optical detector to be used as a system home detector.
6	Stepcl	The motor is moved one step on the rising edge of this signal.
7	CW/CCW	Direction control input. When high or unconnected clockwise rotation is selected. Physical direction of motor rotation depends also on windings connection.
8	Oscillator	The chopper oscillator timing, internally fixed at 17 kHz, can be modified by connecting a resistor between this pin and Vss or a capacitor between this pin and Gnd1. The oscillator input must be grounded when the unit is externally synchronized.
9	Ioset	Phase current setting input. A resistor connected between this pin and Gnd1 or Vss, allows the factory set phase current value (2 A for SPMD250STP) to be changed.
10	Control	Logic input that allows the phase current decay mode selection. When high or unconnected the slow decay is selected.
11	Enable	Module enable input. When low this input floats the outputs enabling the manual positioning of the motor. Must be LOW during power-up and down sequence, HIGH during normal operation.
12	Vss	5 V supply input. Maximum voltage must not exceed 7 V.
13	GND2	Return path for the power section.
14	D	D output.
15	C	C output.
16	B	B output.
17	A	A output.
18	Vs	Module and motor supply voltage. Maximum voltage must not exceed the specified values.

5 Bipolar stepper motor basics

Simplified to the bare essentials, a bipolar permanent magnet motor consists of a rotating permanent magnet surrounded by stator poles carrying the windings (*Figure 5*).

Figure 5. Simplified bipolar two phase motor

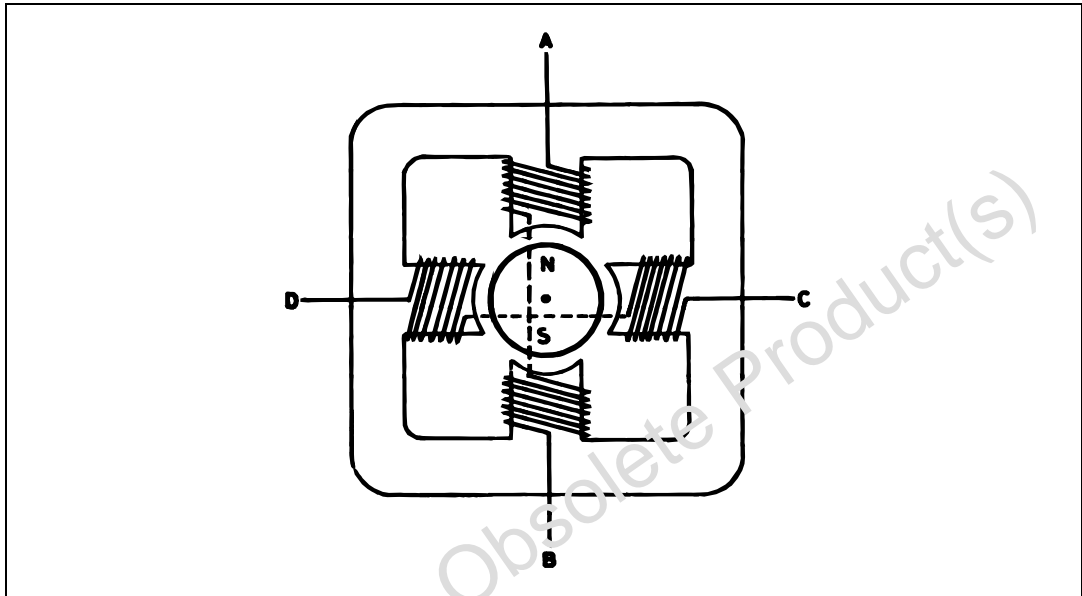

Bidirectional drive current is imposed on windings A-B and C-D and the motor is stepped by commutating the voltage applied to the windings in sequence. For a motor of this type there are three possible drive sequences.

5.1 One-phase-on or wave drive

Only one winding is energized at any given time according to the sequence :

AB - CD - BA - DC

(BA means that the current is flowing from B to A).

Figure 6 shows the sequence for a clockwise rotation and the corresponding rotor position.

5.2 Two-phase-on or normal drive

This mode gives the highest torque since two windings are energized at any given time according to the sequence (for clockwise rotation).

AB & CD ; CD & BA ; BA & DC ; DC & AB

Figure 7 shows the sequence and the corresponding position of the rotor.

5.3 Half step drive

This sequence halves the effective step angle of the motor but gives a less regular torque being one winding or two windings alternatively energized.

Eight steps are required for a complete revolution of the rotor.

The sequence is:

AB ; AB & CD ; CD ; CD & BA ; BA ; BA & DC ; DC ; DC & AB

as shown in *Figure 8*.

By the configurations of *Figure 6, 7, 8* the motor would have a step angle of 90 ° (or 45 ° in half step). Real motors have multiple poles pairs to reduce the step angle to a few degrees but the number of windings (two) and the drive sequence are unchanged.

Figure 6. One-phase-on (wave mode) drive

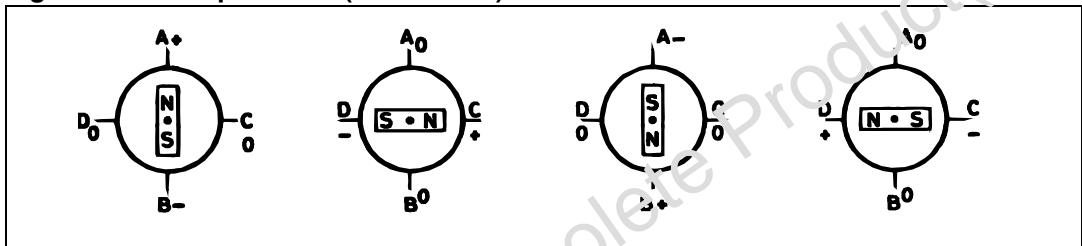

Figure 7. Two-phase-on (normal mode) drive

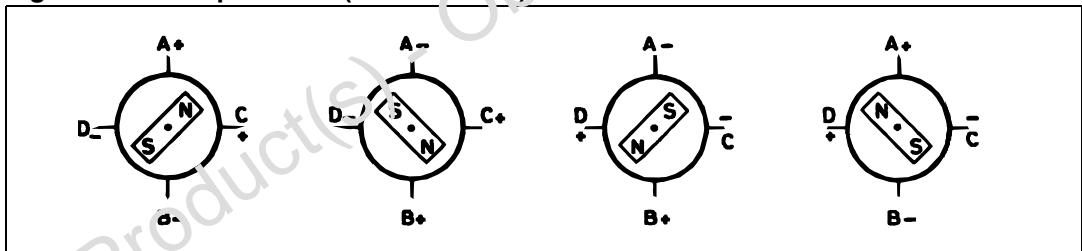
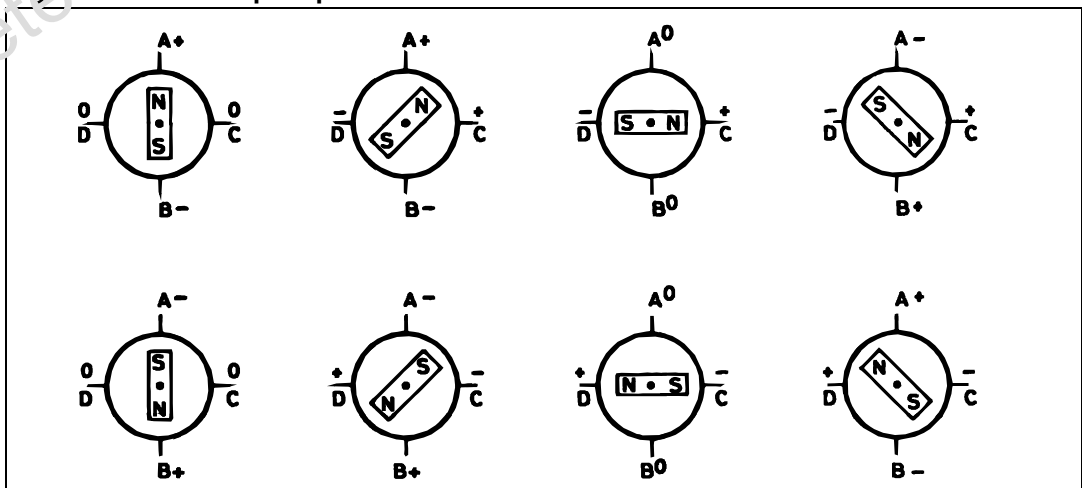

Figure 8. Half step sequence



6 Phase sequence generation inside the device

The module contains a three bit counter plus some combinational logic which generate suitable phase sequences for half step, wave and normal full step drive. This 3 bit counter generates a basic eight-step gray code master sequence as shown

in [Figure 9](#). To select this sequence, that corresponds to half step mode, the HALF/FULL input (pin 4) must be kept high or unconnected.

The full step mode (normal and wave drive) are both obtained from the eight step master sequence by skipping alternate states. This is achieved by forcing the step clock to bypass the first stage of the 3 bit counter. The least significant bit of this counter is not affected and therefore the generated sequence depends on the state of the counter when full step mode is selected by forcing pin 4 (HALF/FULL) low. If full step is selected when the counter is at any odd-numbered state, the twophase-on (normal mode) is implemented (see [Figure 10](#)).

On the contrary, if the full mode is selected when the counter is at an even-numbered state, the one-phase-on (wave drive) is implemented (see [Figure 11](#)).

Figure 9. The eight step master sequence corresponding to half step mode

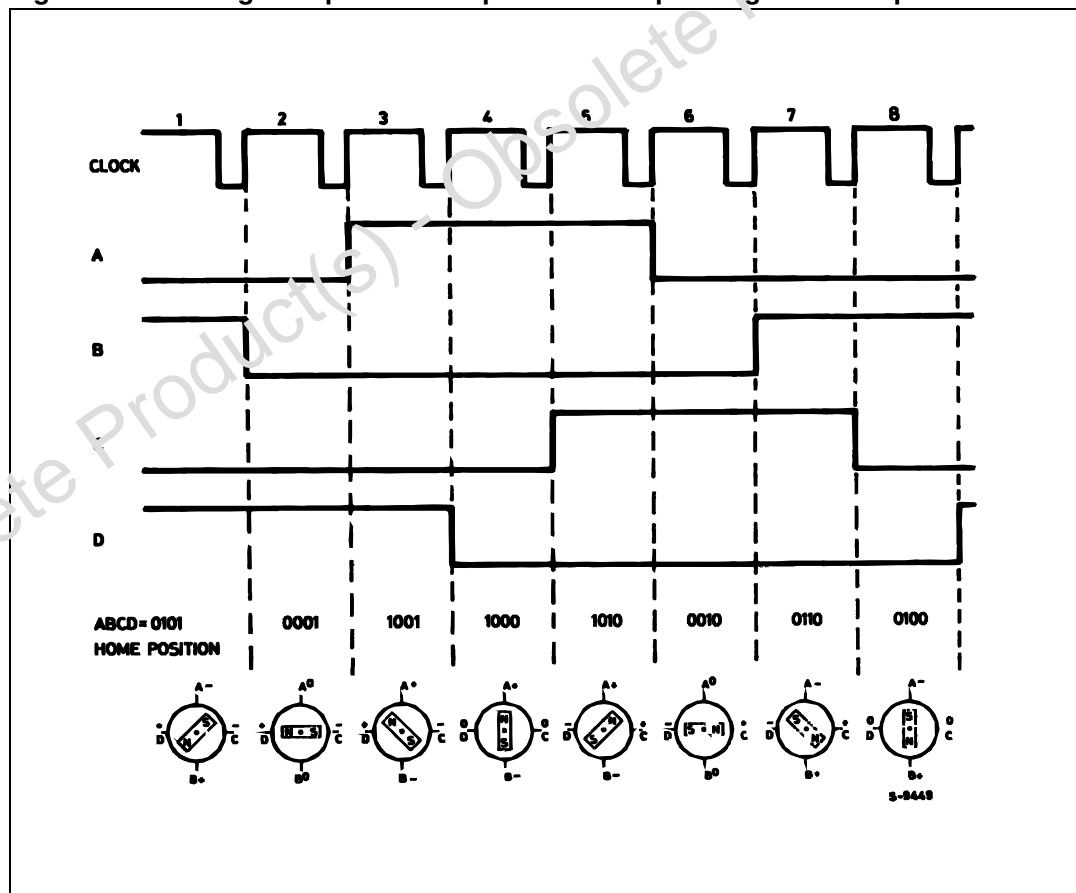
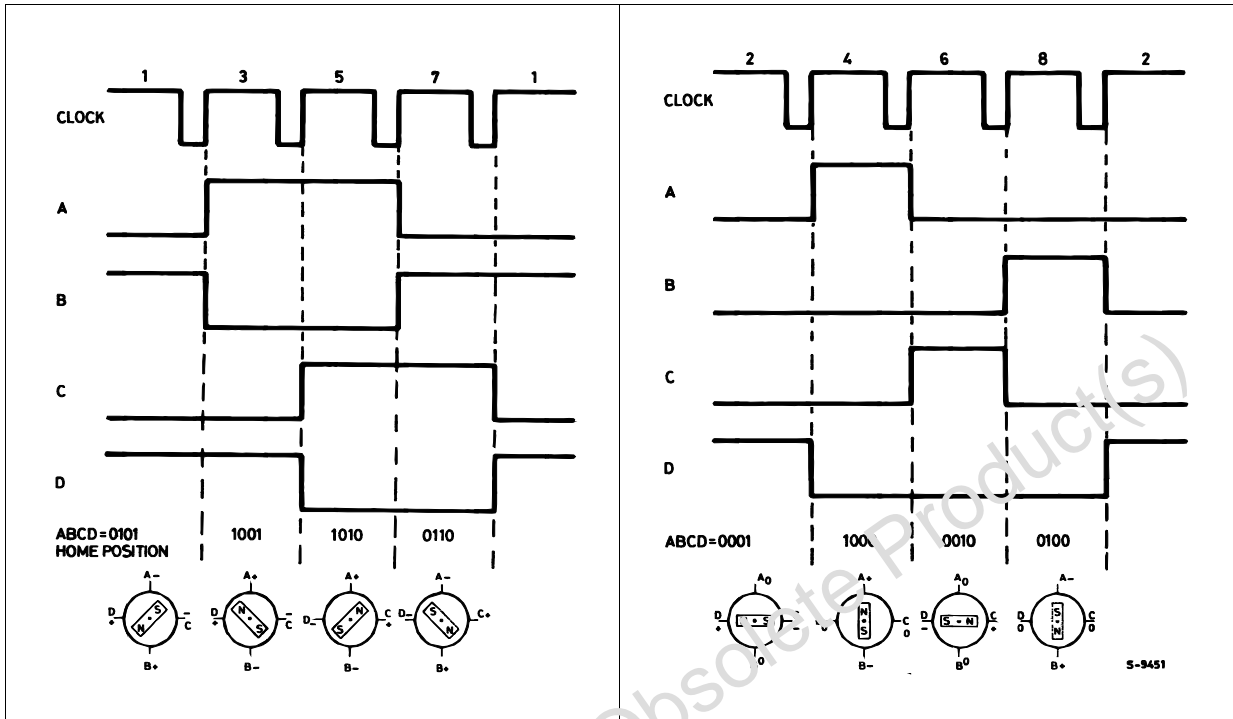

Figure 10. Two-phase-on (normal mode) drive Figure 11. One-phase-on (wave mode) drive



7 RESET, ENABLE and HOME signals

The RESET is an asynchronous reset input which restores the module to the home position (state 1 : ABCD = 0101). Reset is active when low.

The HOME output signals this condition and it is intended to be ANDed with the output of a mechanical home position sensor.

The ENABLE input is used to start up the module after the system initialization. ENABLE is active when high or unconnected.

8 Motor current regulation

The two bipolar winding currents are controlled by two internal choppers in a PWM mode to obtain good speed and torque characteristics.

An internal oscillator supplies pulses at the chopper frequency to both choppers.

When the outputs are enabled, the current through the windings raises until a peak value set by I_{set} and R_{sense} (see the equivalent block diagram) is reached. At this moment the outputs are disabled and the current decays until the next oscillator pulse arrives.

The decay time of the current can be selected by the CONTROL input (pin 10). If the CONTROL input is kept high or open the decay is slow, as shown in [Figure 12](#), where the equivalent power stage and the voltages on A and B are shown as well as the current waveform on winding AB.

When the CONTROL input is forced low, the decay is fast as shown in [fig. 13](#).

The CONTROL input is provided on SPMD250STP to allow maximum flexibility in application.

If the module must drive a large motor that does not store much energy in the windings, the chopper frequency must be decreased: this is easily obtained by connecting an external capacitor between OSC pin and GND1.

In these conditions a fast decay (CONTROL LOW) would impose a low average current and the torque could be inadequate. By selecting CONTROL HIGH, the average current is increased thanks to the slow decay.

When the module is used in the fast-decay mode it is recommended to connect external fast recovery, low drop diodes between each phase output and the supply return (GND). The slow-decay should be the preferred operating recirculation mode because of the lower power dissipation and low noise operations.

Figure 12. Chopper control with slow decay

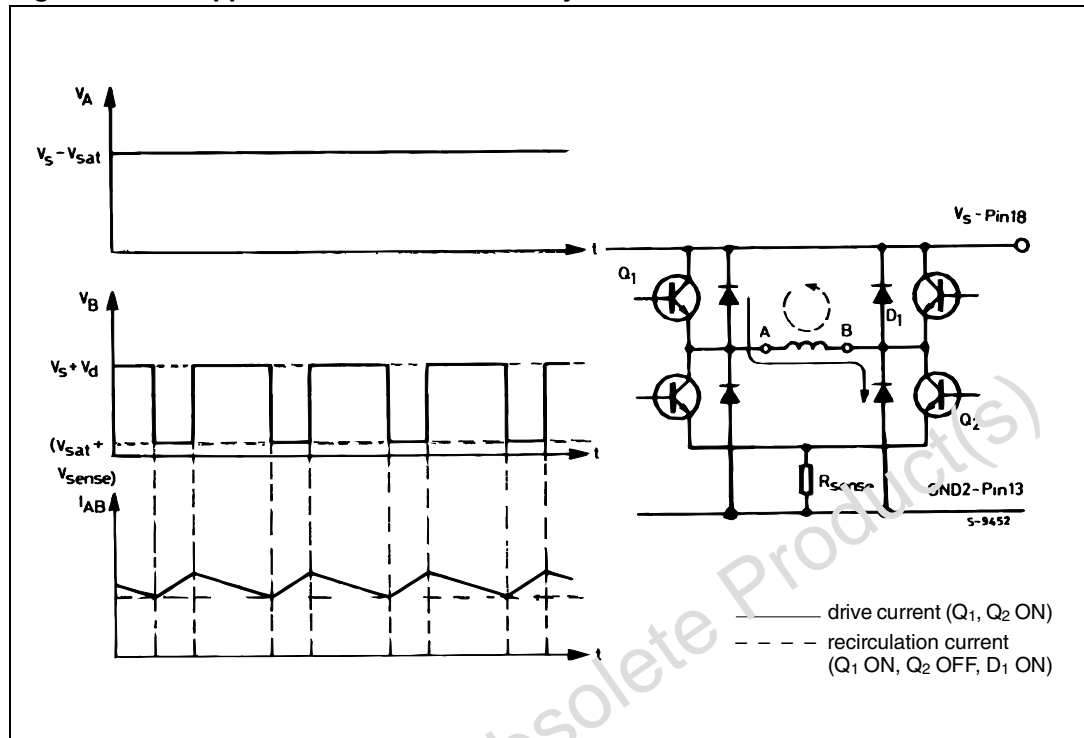
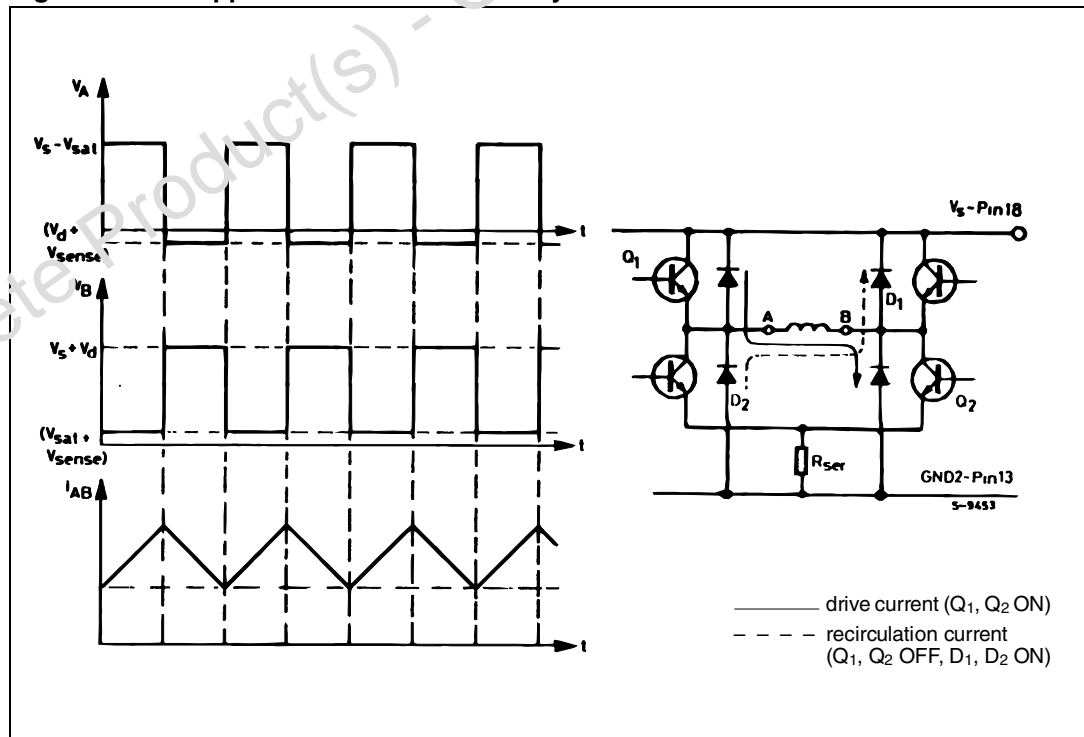

Figure 13. Chopper control with fast decay



9 User notes

9.1 Supply voltage

The recommended operating maximum supply voltage must include the ripple voltage for the Vs rail, and a 5 V \pm 5% for the Vss line is required.

The two supply voltages must to be correctly sequenced to avoid any possible erroneous positioning of the power stages. The correct power-up and power-down sequences are:

- Power-up
 1. Vss (5 V) is applied with enable = Low
 2. Vs (the motor supply voltage) is applied
 3. Enable is brought high
- Power-down
 1. Enable is brought low
 2. Vs is switched off
 3. Vss is switched off.

9.2 Case grounding

The module case is electrically floating. To have a right case grounding, connect module pin 13 (GND2) to the nearest case fixing pin (see [Figure 4](#), [Figure 19](#) and [Figure 20](#)). To obtain additional effective EMI shield, the PCB area below the module can be used as an effective sixth side shield.

9.3 Thermal characteristics

The case-to-ambient thermal resistance is 5 °C/W. This produces a 50 °C temperature increase of the module surface for 10 W of internal dissipation.

According to ambient temperature and/or to power dissipation, an additional heatsink or forced ventilation may be required. (See derating curves [Figure 16](#)).

9.4 Supply line impedance

The module has an internal capacitor connected across the supply pins (18 and 13) to assure the circuit stability. This capacitor cannot handle high values of current ripple, and would be permanently damaged if the primary energy source impedance is not adequate.

The use of a low ESR, high ripple current 470 μ F capacitor located as close to the module as possible is recommended.

When space is a limitation, a 22 μ F ceramic multi-layer capacitor connected across the module input pins must be used.

9.5 Module protections

The SPMD250STP outputs are protected against short circuits to Gnd, Vs and to another output. When the current exceeds the maximum value, the output is automatically disabled.

The module protection is of the latching type, i.e. when an overload condition is detected the unit outputs are disabled. To restart the operations it is necessary to disable the unit (pin 11 = Low) or to switch off the supply voltage for at least 100 ms.

9.6 Motor connection

The motor is normally quite far from the module and long cables are needed for connection. The use of a twisted pair cable with appropriate cross section for each motor phase is recommended to minimize DC losses and RFI problems.

9.7 Unused inputs

All the SPMD250STP logic inputs have an internal pull-up, and they are high when unconnected.

9.8 Phase current programming

The output current is factory set to a standard 2 A value.

The phase current value can be changed by connecting an appropriate resistor between pin 9 and ground or Vss (see [Figure 14](#)). In the first case the phase current will decrease, in the latter it will increase.

The maximum phase current must be limited to 2.5 A, to avoid permanent damage to the module.

SPMD250STP phase current programming:

Equation 1

$$I > 2A \quad R_i = \frac{10 - 0.33 \cdot I}{0.473 \cdot I - 1} = k\Omega \quad R_i \geq 50k\Omega$$

Equation 2

$$I < 2A \quad R_d = \frac{I}{3.03 - 1.43 \cdot I} = k\Omega$$

Figure 14. Phase current programming

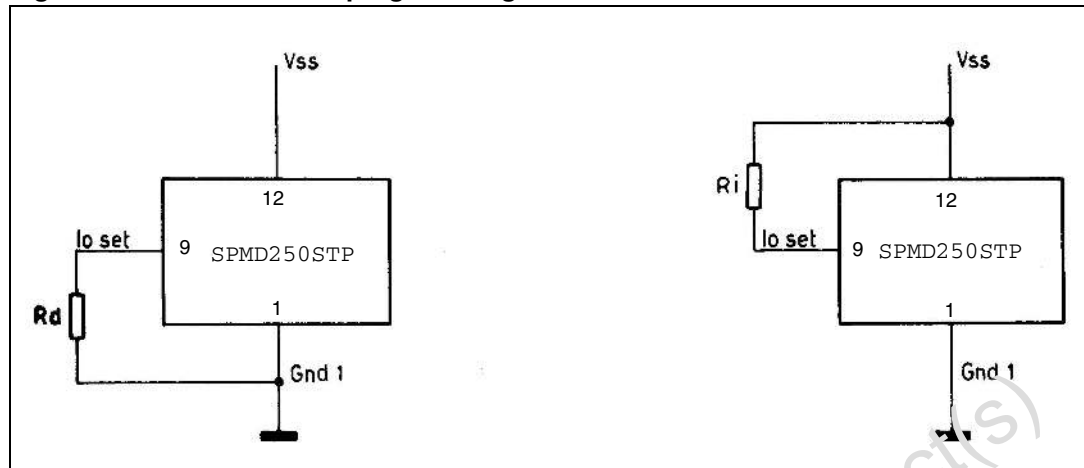

9.9 Chopper frequency programming

The chopper frequency is internally set to 17 kHz, and it can be changed by addition of external components as follows. To increase the chopper frequency a resistor must be connected between oscillator (pin 8) and Vss (pin 12, see [Figure 15](#)). The resistor value is calculated according to the formula:

Equation 3

$$R_f = \frac{306}{f_c - 17} = k\Omega \quad \text{where} \quad f_c = \text{kHz} \quad R_f \geq 18k\Omega$$

To decrease the chopper frequency a capacitor must be connected between oscillator (pin 8) and Gnd1 (pin 1). The capacitor value is calculated according to the formula:

Equation 4

$$C_f = \frac{80.5 - 4.7f_c}{f_c} = \text{nF} \quad \text{where} \quad f_c = \text{kHz}$$

Figure 15. Chopper frequency programming

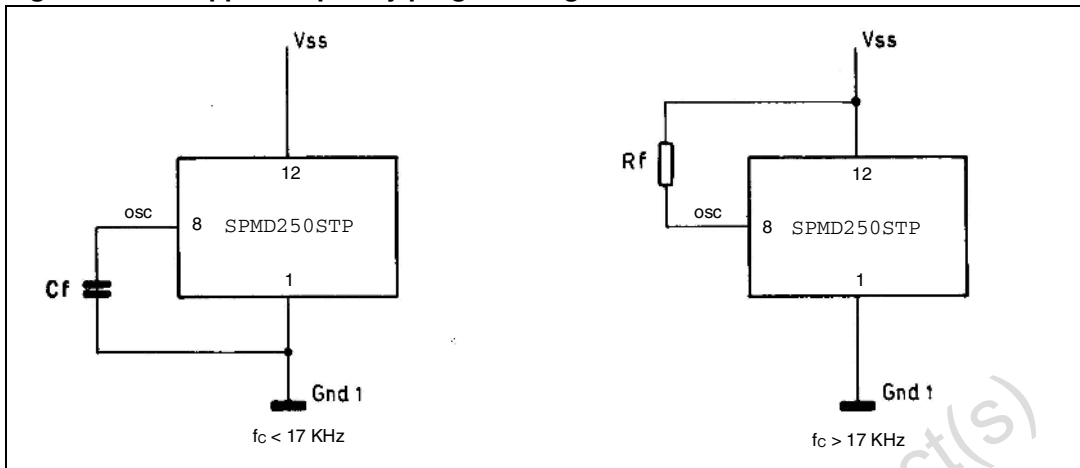
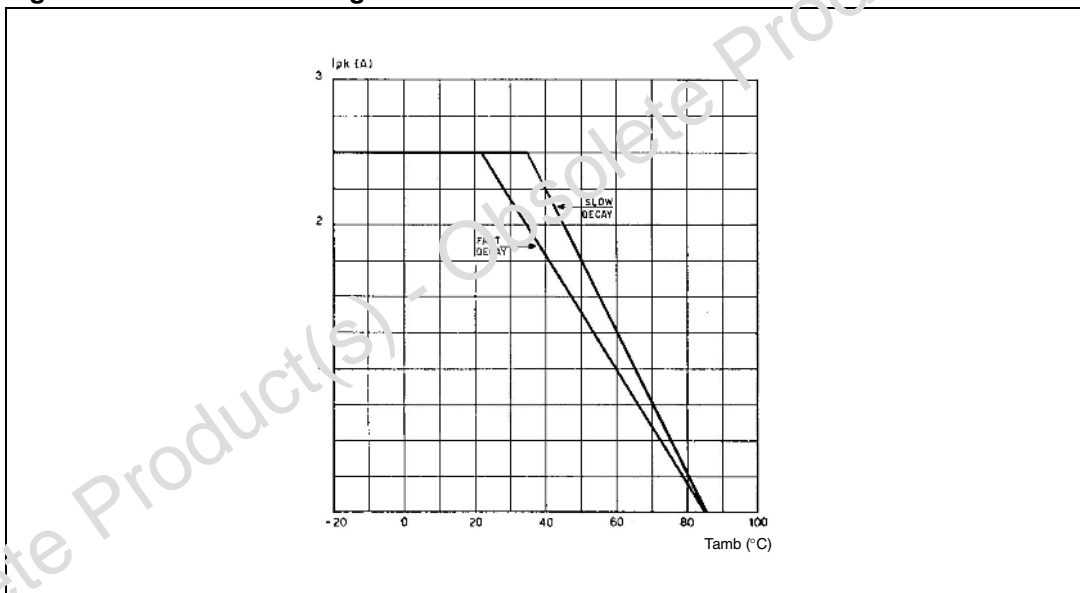

Figure 16. Free air derating curve



10 Multi modules application

In complex systems, many motors must be controlled and driven. In such a case more than one SPMD250STP must be used.

To avoid chopper frequencies noise and beats, all the modules should be synchronized.

If all the motors are relatively small, the fast decay may be used, the chopper frequency does not need any adjustment and [Figure 17](#) shows how to synchronize several modules.

When at least one motor is relatively large a lower chopper frequency and a slow decay may be required: In such a case the overall system chopper frequency is determined by the largest motor in the system as shown in [Figure 18](#).

Figure 17. Multi-motor synchronization, small motor and fast current decay

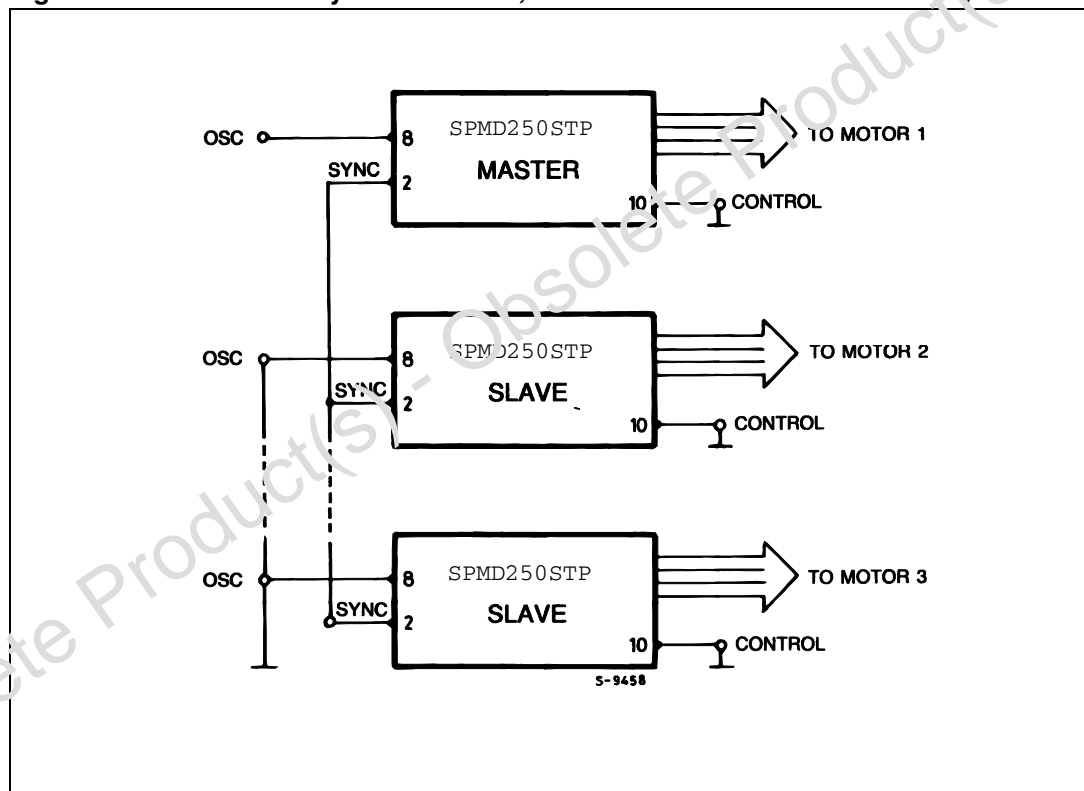
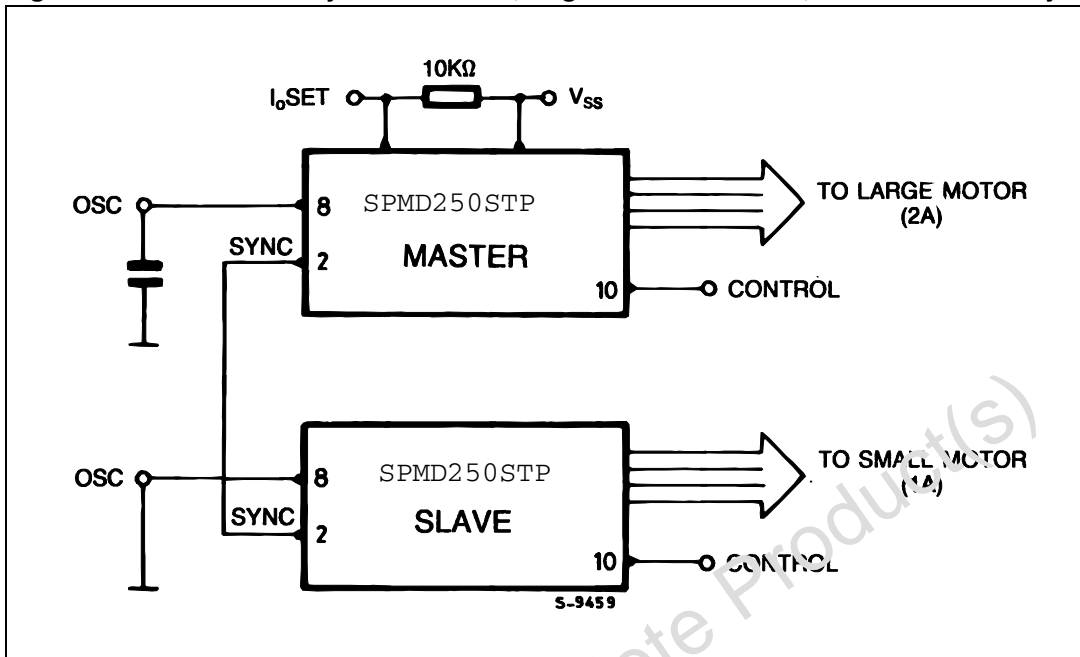

Figure 18. Multi-motor synchronization, large and small motor, slow current decay



Obsolete Product(s) - Obsolete Product(s)

11 Thermal operating conditions

In many cases the modules do not require any additional cooling because the dimensions and the shape of the metal box are studied to offer the minimum possible thermal resistance case-to-ambient for a given volume.

It should be remembered that these modules are a power device and, depending on ambient temperature, an additional heat-sink or forced ventilation or both may be required to keep the unit within safe temperature range. ($T_{casemax} < 85\text{ °C}$ during operation).

The concept of maximum operating ambient temperature is totally meaningless when dealing with power components because the maximum operating ambient temperature depends on how a power device is used.

What can be unambiguously defined is the case temperature of the module.

To calculate the maximum case temperature of the module in a particular applicative environment the designer must know the following data:

- Input voltage
- Motor phase current
- Motor phase resistance
- Maximum ambient temperature

From these data it is easy to determine whether an additional heat-sink is required or not, and the relevant size i.e. the thermal resistance.

The step by step calculation is shown for the following example.

$V_{in} = 40\text{ V}$, $I_{phase} = 1\text{ A}$, R_{ph} phase resistance = $10\ \Omega$, max. $T_A = 50\text{ °C}$

- Calculate the power dissipated from the indexer logic and the level shifter (see electrical characteristics):
 $P_{logic} = (5\text{ V} \times 60\text{ mA}) + (40\text{ V} \times 20\text{ mA}) = 1.1\text{ W}$
- Calculate the average voltage across the winding resistance:
 $V_{out} = (R_{ph} \times I_{out}) = 10\ \Omega \rightarrow 1\text{ A} = 10\text{ V}$
- Calculate the required ON duty cycle (D.C.) of the output stage to obtain the average voltage (this D.C. is automatically adjusted by the SPMD250STP):
 $DC = \frac{V_{OUT}}{V_{IN}} = \frac{10}{40} = 0.25$
- Calculate the power dissipation of the SPMD250STP output power stage. The power dissipation depends on two main factors:
 - The selected operating mode (FAST or SLOW DECAY)
 - The selected drive sequence (WAVE, NORMAL, HALF STEP)

FAST DECAY. For this mode of operation, the internal voltage drop is $V_{satsource} + V_{satsink}$ during the ON period i.e. for 25% of the time.

During the recirculation period (75% of the time), the current recirculates on two internal diodes that have a voltage drop $V_d = 1\text{ V}$, and the internal sense resistor ($0.5\ \Omega$). For this example, by assuming maximum values for conservative calculations, the power dissipation during one cycle is:

$$P_{pw} = 1.1 \times [2 V_{sat} \times I_{ph} \times D.C. + 2 V_d \times I_{ph} \times (1 - D.C.) + 0.5 \times I_{ph}]$$

$$P_{pw} = 1.1 \times [2 \times 1.8 \times 1 \times 0.25 + 2 \times 1 \times 1 \times 0.75 + 0.5 \times 1]$$

$$P_{pw} = 1.1 \times [0.9 + 1.5 + 0.5] = 3.19 \text{ W}$$

The factor 1.1 takes into account the power dissipation during the switching transient.

SLOW DECAY. The power dissipation during the ON period is the same. The RECIRCULATION is made internally through a power transistor (Vsatsink) and a diode. The power dissipation is, therefore:

$$P_{pw} = 1.1 \times [2 \text{ Vsat} \times I_{ph} \times D.C. + (\text{Vsat} + V_d) \times I_{ph} \times (1 - D.C.)]$$

$$P_{pw} = 1.1 \times [2 \times 1.8 \times 1 \times 0.25 + (1.8 + 1) \times 1 \times 0.75]$$

$$P_{pw} = 1.1 \times [0.9 + 2.1] = 3.3 \text{ W}$$

WAVE MODE. When operating in this mode the power dissipation is given by values of FAST and SLOW DECAY mode, because one phase is energized at any given time.

NORMAL MODE. At any given time, two windings are always energized. The power dissipation of the power output stage is therefore multiplied by a factor 2.

HALF STEP. The power sequence, one-phase-on, two-phase-on forces the power dissipation to be 1.5 times higher than in WAVE MODE when the motor is running. In stall condition the worst case for power dissipation is with two phase-on i.e. a power dissipation as in NORMAL MODE.

The following table summarizes the power dissipations of the output power stage of the SPMD250STP when running for this example:

Table 5. Power dissipations

	Wave	Normal	Half step
Fast Decay	3.19 W	6.38 W	6.38 W
Slow Decay	3.30 W	6.60 W	6.60 W

- Calculate the total power dissipation for the SPMD250STP :
 $P_{tot} = P_{logic} + P_{pw}$

In this example, for slow decay and normal mode

$$P_{tot} = 1.1 + 6.6 = 7.7 \text{ W}$$

- The case temperature can now be calculated:

$$T_{case} = T_{amb} + (P_{tot} \times R_{th}) = 55 + (7.7 \times 5) = 93.5 \text{ }^\circ\text{C}$$

- If the calculated case temperature exceeds the maximum allowed case temperature, as in this example, an external heat-sink is required and the thermal resistance can be calculated according to:

Equation 5

$$R_{th_{tot}} = \frac{T_{cmax} - T_{amb}}{P_{tot}} = \frac{85 - 55}{7.7} = 3.9^\circ\text{C}$$

Equation 6

$$R_{th_{hs}} = \frac{R_{th} \cdot R_{th_{tot}}}{R_{th} - R_{th_{tot}}} = \frac{5 \cdot 3.9}{5 - 3.9} = 17.7^{\circ}\text{C}$$

The following table gives the thermal resistance of some commercially available heath-sinks that fit on the SPMD250STP module.

Table 6. Thermal resistance

Manufacturer	Part number	Rth (°C/W)	Mounting
Thermalloy	6177	3	Horizontal
Thermalloy	6152	4	Vertical
Thermalloy	6111	10	Vertical
Fischer	SK18	3	Vertical
Assman	V5440	4	Vertical
Assman	V5382	4	Horizontal

12 Package mechanical data

In order to meet environmental requirements, ST offers these devices in different grades of ECOPACK® packages, depending on their level of environmental compliance. ECOPACK® specifications, grade definitions and product status are available at: www.st.com. ECOPACK® is an ST trademark.

Figure 19. Mechanical data

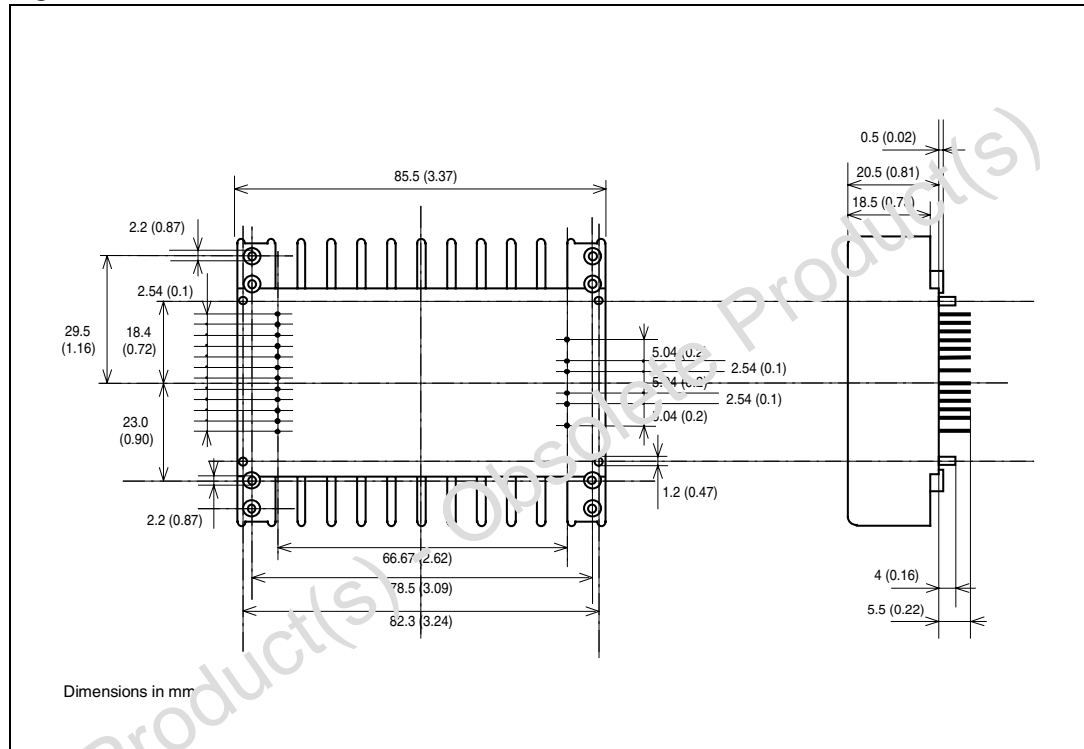
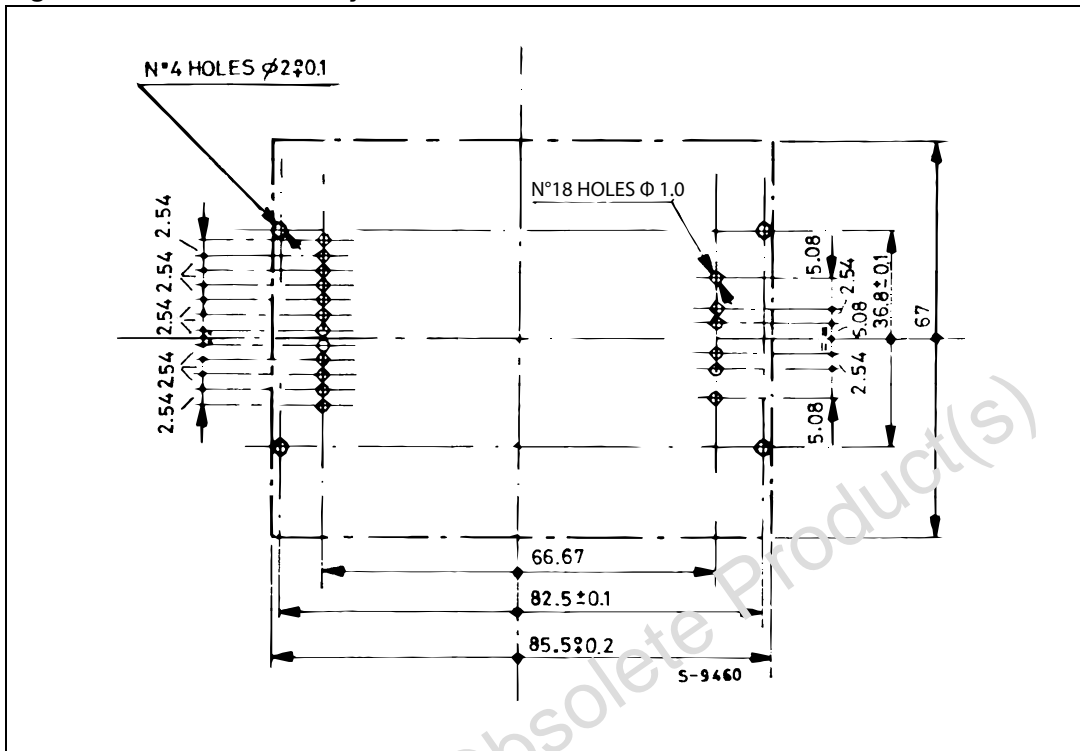

Figure 20. Motherboard layout



Obsolete Product(s) - Obsolete Product(s)

13 Revision history

Table 7. Document revision history

Date	Revision	Changes
23-Jan-2007	1	First release
19-May-2009	2	Updated: Section 9.2 on page 16 , Figure 19 and Figure 20 on page 26

Obsolete Product(s) - Obsolete Product(s)

Please Read Carefully:

Information in this document is provided solely in connection with ST products. STMicroelectronics NV and its subsidiaries ("ST") reserve the right to make changes, corrections, modifications or improvements, to this document, and the products and services described herein at any time, without notice.

All ST products are sold pursuant to ST's terms and conditions of sale.

Purchasers are solely responsible for the choice, selection and use of the ST products and services described herein, and ST assumes no liability whatsoever relating to the choice, selection or use of the ST products and services described herein.

No license, express or implied, by estoppel or otherwise, to any intellectual property rights is granted under this document. If any part of this document refers to any third party products or services it shall not be deemed a license grant by ST for the use of such third party products or services, or any intellectual property contained therein or considered as a warranty covering the use in any manner whatsoever of such third party products or services or any intellectual property contained therein.

UNLESS OTHERWISE SET FORTH IN ST'S TERMS AND CONDITIONS OF SALE ST DISCLAIMS ANY EXPRESS OR IMPLIED WARRANTY WITH RESPECT TO THE USE AND/OR SALE OF ST PRODUCTS INCLUDING WITHOUT LIMITATION IMPLIED WARRANTIES OF MERCHANTABILITY, FITNESS FOR A PARTICULAR PURPOSE (AND THEIR EQUIVALENTS UNDER THE LAWS OF ANY JURISDICTION), OR INFRINGEMENT OF ANY PATENT, COPYRIGHT OR OTHER INTELLECTUAL PROPERTY RIGHT.

UNLESS EXPRESSLY APPROVED IN WRITING BY AN AUTHORIZED ST REPRESENTATIVE, ST PRODUCTS ARE NOT RECOMMENDED, AUTHORIZED OR WARRANTED FOR USE IN MILITARY, AIR CRAFT, SPACE, LIFE SAVING, OR LIFE SUSTAINING APPLICATIONS, NOR IN PRODUCTS OR SYSTEMS WHERE FAILURE OR MALFUNCTION MAY RESULT IN PERSONAL INJURY, DEATH, OR SEVERE PROPERTY OR ENVIRONMENTAL DAMAGE. ST PRODUCTS WHICH ARE NOT SPECIFIED AS "AUTOMOTIVE GRADE" MAY ONLY BE USED IN AUTOMOTIVE APPLICATIONS AT USER'S OWN RISK.

Resale of ST products with provisions different from the statements and/or technical features set forth in this document shall immediately void any warranty granted by ST for the ST product or service described herein and shall not create or extend in any manner whatsoever, any liability of ST.

ST and the ST logo are trademarks or registered trademarks of ST in various countries.

Information in this document supersedes and replaces all information previously supplied.

The ST logo is a registered trademark of STMicroelectronics. All other names are the property of their respective owners.

© 2009 STMicroelectronics - All rights reserved

STMicroelectronics group of companies

Australia - Belgium - Brazil - Canada - China - Czech Republic - Finland - France - Germany - Hong Kong - India - Israel - Italy - Japan - Malaysia - Malta - Morocco - Philippines - Singapore - Spain - Sweden - Switzerland - United Kingdom - United States of America

www.st.com