

General Description

The AOZ6134 is a high performance single-pole double-throw (SPDT), low power, TTL-compatible bus switch.

The AOZ6134 will accept analog and digital signals. Signals with voltages up to V_{CC} (1.65 V to 5.5 V) can be transmitted in either direction.

When the Select pin is LOW, B_0 is connected to the output A pin. When the Select pin is HIGH, B_1 is connected to the output A pin. The path that is open will have a high-impedance state with respect to the output. Break-before-make is guaranteed.

Features

- DFN 1.2 mm x 1.0 mm x 0.55 mm 6-Lead Package
- 1.65 V to 5.5 V V_{CC} operation
- $1\ \Omega$ connection between ports
- Break-before-make switching



Typical Application

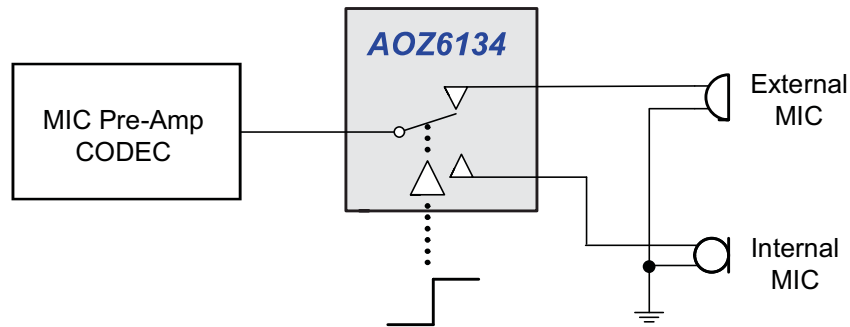

Ordering Information

Part Number	Ambient Temperature Range	Package	Environmental
AOZ6134DI	-40 °C to +85 °C	DFN 1.2 mm x 1.0 mm, 6L	RoHS Compliant Green Product



AOS Green Products use reduced levels of Halogens, and are also RoHS compliant.
Please visit www.aosmd.com/web/quality/rohs_compliant.jsp for additional information.

Pin Configuration

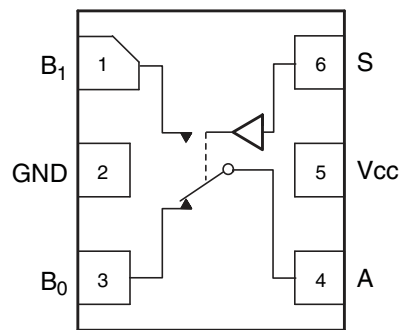

DFN-6
(Top Thru View)

Truth Table

Logic S Input	Function
0	B ₀ Connected to A
1	B ₁ Connected to A

Absolute Maximum Ratings

Exceeding the Absolute Maximum ratings may damage the device.

Symbol	Parameter	Rating
V _{CC}	Supply Voltage	-0.5 V to +6 V
V _S	Switch Voltage ⁽¹⁾	-0.5 V to V _{CC}
V _{IN}	Input Voltage ⁽¹⁾	-0.5 V to V _{CC}
I _{IK}	Minimum Input Diode Current ⁽²⁾	-50 mA
I _{SW}	Switch Current	200 mA
I _{SWPEAK}	Peak Switch Current (Pulsed at 1 ms, < 10% Duty Cycle)	400 mA
T _{STG}	Storage Temperature Range	-65 °C to +150 °C
T _J	Maximum Junction Temperature	+150 °C
P _D	DFN-6 Power Dissipation at 85 °C ⁽³⁾	560 mW
ESD	Human Body Model (JEDEC22A-114E)	8000 V

Recommend Operating Ratings

The device is not guaranteed to operate beyond the Maximum Operating Ratings.

Symbol	Parameter	Rating
V _{CC}	Supply Voltage	1.65 V to +5.5 V
V _{IN}	Control Input Voltage ⁽⁴⁾	0 V to V _{CC}
V _{SW}	Switch Input Voltage	0 V to V _{CC}
T _A	Operating Temperature	-40 °C to +85 °C

Notes:

1. Signals on A, or B or S exceeding V+ will be clamped by internal diodes. Limit forward diode current to maximum current ratings.
2. Negative current should not exceed minimum negative value.
3. All leads welded or soldered to PC Board.
4. Unused inputs must be held HIGH or LOW. They may not float.

Electrical Characteristics

Unless otherwise indicated, specifications indicate a temperature range of -40 °C to +85 °C. All typical values are at 25 °C unless otherwise specified.

Symbol	Parameter	Test Conditions	V _{CC} (V)	Min.	Typ.	Max.	Units
DC CHARACTERISTICS							
V _{IH}	Input Voltage High		1.65 to 2.7	1.0			V
			2.7 to 3.6	1.5			
			4.5 to 5.5	2.0			
V _{IL}	Input Voltage Low		1.65 to 2.7			0.4	V
			2.7 to 3.6			0.6	
			4.5 to 5.5			0.8	
R _{ON}	On Resistance	I _{OUT} = 100 mA, B0 or B1 = 0 V, 1.5 V, 2.5 V, 3.5 V, 3.75 V, or 4.5 V	4.5		0.6	1.2	Ω
		I _{OUT} = 100 mA, B0 or B1 = 0 V, 1.5 V, 2 V, or 2.7 V	2.7		1.0	1.5	
		I _{OUT} = 100 mA, B0 or B1 = 0 V, 1.25 V, 1.5 V, or 1.8 V	1.8		3.0	6.0	
R _{FLAT}	On Resistance Flatness	I _{OUT} = 100 mA, B0 or B1 = 0 V to V _{CC}	4.5		0.2		Ω
			2.7		0.4		
			1.8		2.5		
ΔR _{ON}	On Resistance Matching Between Channels	I _{OUT} = 100 mA, B0 or B1 = 1.5 V	4.5		0.03	0.15	Ω
		I _{OUT} = 100 mA, B0 or B1 = 3.5 V					
I _{IN}	Input Leakage Current	V _{IN} = 0 V or V _{CC}	1.95 to 5.5			±1.0	μA
I _{B(off)}	Off Stage Switch Leakage	A = 1 V, 4.5 V, B0 or B1 = 4.5 V, 1 V	1.95 to 5.5			±30	nA
I _{A(on)}	On State Switch Leakage	A = 1 V, 4.5 V, B0 or B1 = 4.5 V, 1 V or floating	1.95 to 5.5			±40	nA
POWER SUPPLY							
V _{CC}	Power Supply Range		1.65 to 5.5	1.65		5.5	V
I _{CCQ}	Quiescent Supply Current	V _{IN} = 0 V or V _{CC} , I _{OUT} = 0 V	5.5			0.5	μA
I _{CCT}	Increase in I _{CC} per Input	V _{IN} = 1.8 V	5.5		30	40	μA
		V _{IN} = 2.6 V			18	25	

Electrical Characteristics (Continued)

Unless otherwise indicated, specifications indicate a temperature range of -40 °C to +85 °C. All typical values are at 25 °C unless otherwise specified.

Symbol	Parameter	Test Conditions	V _{CC} (V)	Min.	Typ.	Max.	Units
AC CHARACTERISTICS							
t _{ON}	Turn-On Time	B ₀ or B ₁ = 1.5 V, R _L = 50 Ω, C _L = 35 pF	2.7 to 3.6			70 65	ns
			4.5 to 5.5			55 55	
t _{OFF}	Turn-Off Time	B ₀ or B ₁ = 1.5 V, R _L = 50 Ω, C _L = 35 pF	2.7 to 3.6			50 45	ns
			4.5 to 5.5			45 45	
t _{BBM}	Break-Before-Make Time		1.65 to 1.95		20		ns
			2.3 to 2.7		15		
			3.0 to 3.65		10		
			4.5 to 5.5		10		
Q	Charge Injection ⁽²⁾	C _L = 1.0 nF, V _{GE} = 0 V, R _{GEN} = 0 Ω	4.5 to 5.5		90		pC
			2.7 to 3.6		50		
ANALOG SWITCH CHARACTERISTICS⁽²⁾							
OIRR	Off Isolation	R _L = 50 Ω, f = 1 MHz	2.7 to 5.5		-60		dB
X _{TALK}	Crosstalk	R _L = 50 Ω, f = 1 MHz	2.7 to 5.5		-60		dB
BW	-3 dB Bandwidth	R _L = 50 Ω	2.7 to 5.5		180		MHz
THD	Total Harmonic Distortion	V _{IN} = 2 V _{pk-pk} , f = 20 Hz to 20 kHz	2.7 to 5.5		0.002		%
CAPACITANCE⁽³⁾							
C _{IN}	Control Pin Capacitance	f = 1 MHz, V _{bias} = 1.5 V	4.5		3.0		pF
C _{OFF}	B Port Off Capacitance	f = 1 MHz, V _{bias} = 1.5 V	4.5		7.0		pF
C _{ON}	A Port Capacitance When Switch Enable	f = 1 MHz, V _{bias} = 1.5 V	4.5		40.0		pF

Notes:

1. Typical values are for design aid only, not guaranteed nor subject to production testing.
2. T_A = +25 °C, parameters are characterized but not tested in production and guaranteed by design.
3. T_A = +25 °C, f = 1 MHz, capacitance is characterized but not tested in production.

AC Loading and Waveforms

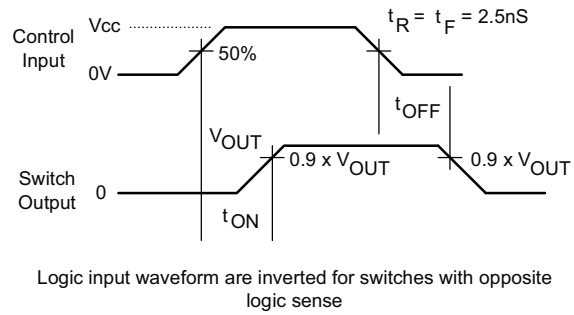
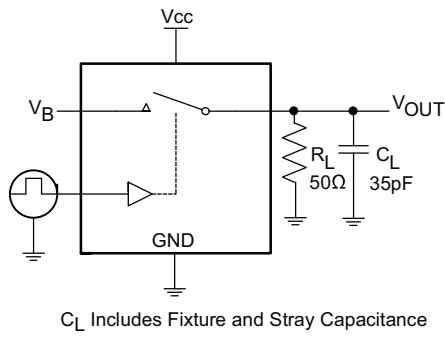

Figure 1. Turn-On/Turn-Off Timing

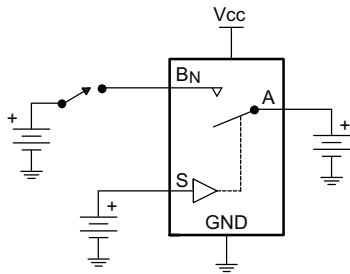

Figure 2. Off State Leakage Current

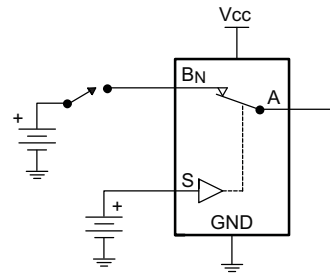

Figure 3. On State Leakage Current

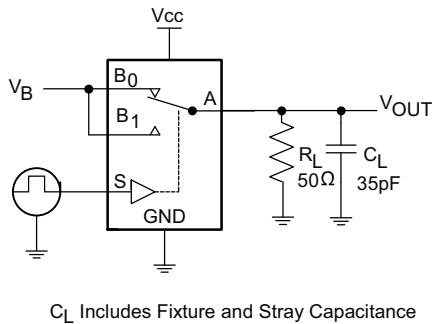

Figure 4. Break-Before-Make Timing

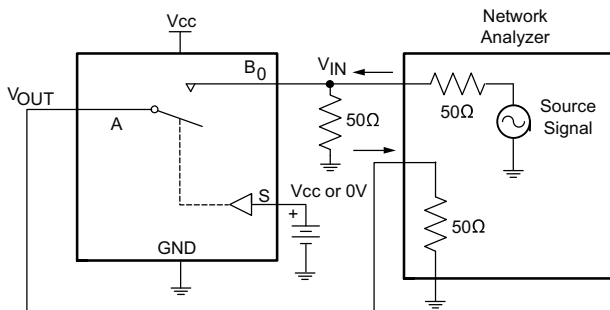
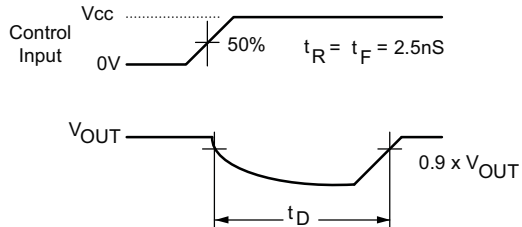

Figure 5. Off Isolation

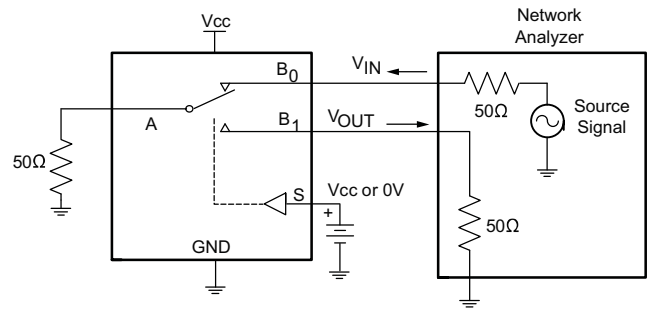

Figure 6. Crosstalk

AC Loading and Waveforms (Continued)

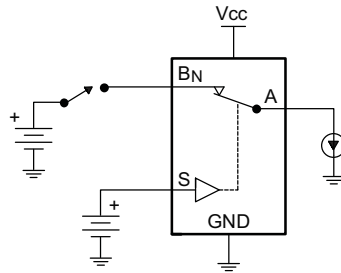

Figure 7. On State Resistance

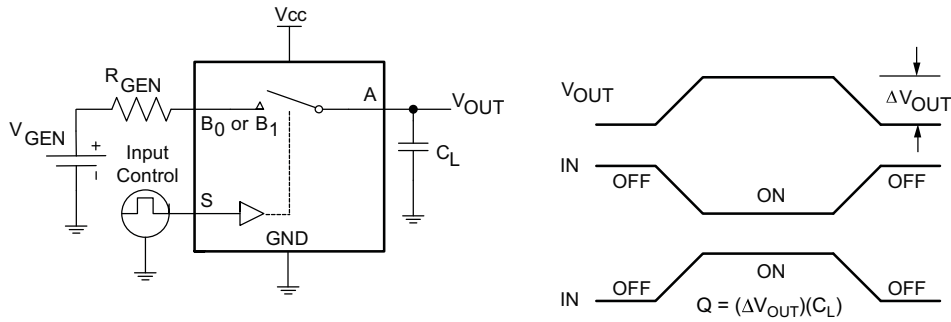

Figure 8. Charge Injection

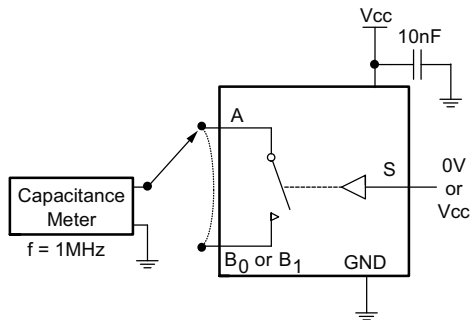

Figure 9. ON/Off Capacitance Measurement

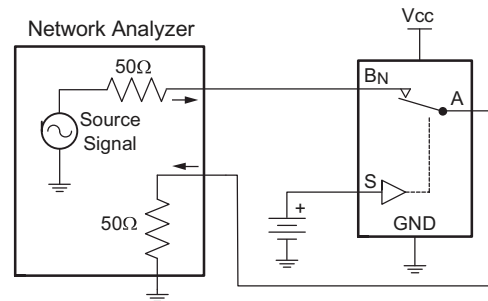

Figure 10. Bandwidth

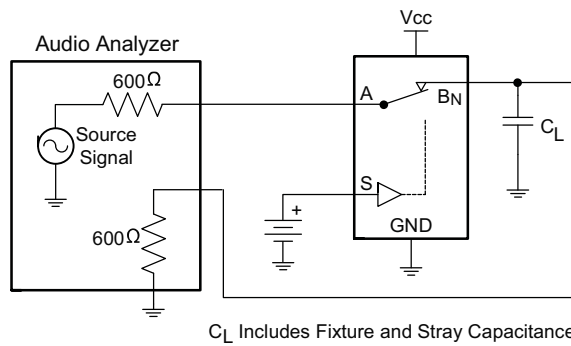
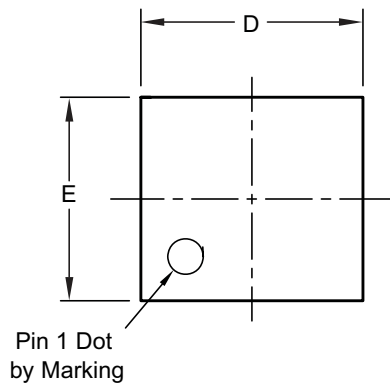
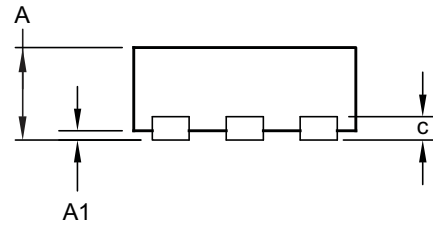

Figure 11. Harmonic Distortion

Package Dimensions, DFN 1.2 mm x 1.0 mm, 6L



TOP VIEW



SIDE VIEW

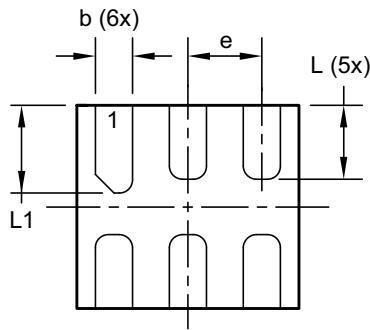

BOTTOM VIEW

RECOMMENDED LAND PATTERN

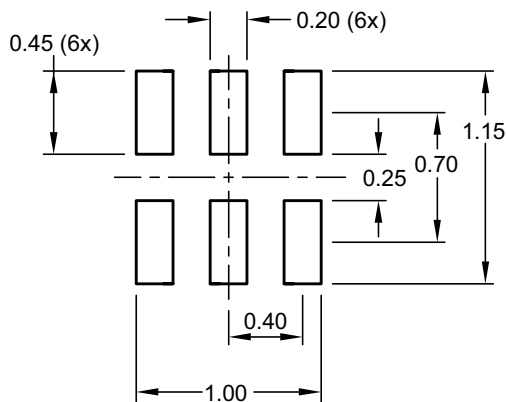

UNIT: mm

Dimensions in millimeters

Symbols	Min.	Nom.	Max.
A	0.50	0.55	0.60
A1	0.00	—	0.05
b	0.15	0.20	0.25
c	0.152 Ref.		
D	1.05		1.25
E	0.95		1.15
e	0.40 BSC		
L	0.30	0.40	0.50
L1	0.375	0.475	0.575

Dimensions in inches

Symbols	Min.	Nom.	Max.
A	0.020	0.022	0.024
A1	0.000	—	0.002
b	0.006	0.008	0.010
c	0.006 Ref.		
D	0.045	0.047	0.049
E	0.041	0.043	0.045
e	0.016 BSC		
L	0.012	0.016	0.020
L1	0.015	0.019	0.023

Note:

- Controlling dimension is millimeter, converted inch dimensions are not necessarily exact.

Part Marking

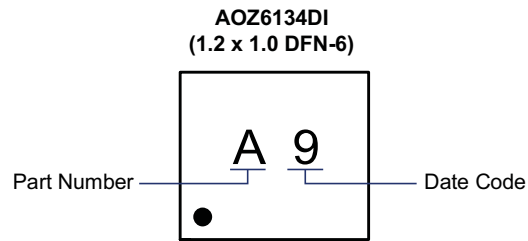

This datasheet contains preliminary data; supplementary data may be published at a later date. Alpha & Omega Semiconductor reserves the right to make changes at any time without notice.

LIFE SUPPORT POLICY

ALPHA & OMEGA SEMICONDUCTOR PRODUCTS ARE NOT AUTHORIZED FOR USE AS CRITICAL COMPONENTS IN LIFE SUPPORT DEVICES OR SYSTEMS.

As used herein:

- | | |
|---|---|
| <p>1. Life support devices or systems are devices or systems which, (a) are intended for surgical implant into the body or (b) support or sustain life, and (c) whose failure to perform when properly used in accordance with instructions for use provided in the labeling, can be reasonably expected to result in a significant injury of the user.</p> | <p>2. A critical component in any component of a life support, device, or system whose failure to perform can be reasonably expected to cause the failure of the life support device or system, or to affect its safety or effectiveness.</p> |
|---|---|