

RN41XV & RN42XV Bluetooth Module

Features:

- Fully qualified Bluetooth® version 2.1 Class 1 (RN41XV) and Class 2 (RN42XV) data module, supports version 2.1 + Enhanced Data Rate (EDR)
- Backwards-compatible with Bluetooth version 2.0, 1.2, and 1.1
- Pin compatible with widely used 2 x 10 2-mm socket typically used by 802.15.4 applications
- RN42XV: 26 µA sleep, 3 mA connected, 30 mA transmit
- RN41XV: 30 mA connected, < 10 mA sniff mode
- UART data connection interface
- Supports secure simple pairing (SPP)
- Sustained data rates: 240 Kbps (slave), 300 Kbps (master)
- Embedded Bluetooth stack profiles: SPP and HID profile support as well as GAP, SDP, RFCOMM, and L2CAP protocols
- Bluetooth SIG certified
- Certifications: FCC, IC, CE
- Environmentally friendly, RoHS compliant

Applications:

- Bluetooth replacement for 802.15.4 modules
- Cable replacement
- Barcode scanners/readers
- Measurement and monitoring systems
- Industrial sensors and controls
- Medical devices
- Computer accessories
- Asset tracking



1.0 DESCRIPTION

The RN41XV and RN42XV are small form factor, low-power Bluetooth radio modules offering plug-in compatibility for the widely used 2 x 10 (2-mm) socket typically used by 802.15.4 radio modules.

Based on the popular 2 x 10 (2-mm) socket footprint often found in embedded applications, the Roving Networks' RN41XV and RN42XV modules provide Bluetooth connectivity in legacy and existing designs that may have been based upon the 802.15.4 standard.

The RN41XV Class 1 Bluetooth module is based on the RN41, and the RN42XV Class 2 Bluetooth module is based on the RN42. These modules are simple to design in and are fully certified, making them a complete embedded Bluetooth solution. The RN42 is functionally compatible with the RN41.

The Class 1 RN41 module has a range up to 100 meters. The Class 2 RN42 module has a range up to 20 meters.

2.0 OVERVIEW

- Pin compatible with 2 x 10 (2-mm) socket
- Baud rate speeds: 1,200 bps up to 921 Kbps, non-standard baud rates can be programmed
- RN41XV: Class 1 radio, 330 feet (100 m) range, +16 dBm output transmitter, -80 dBm typical receive sensitivity
- RN42XV: Class 2 radio, 60 feet (20 m) distance, +4 dBm output transmitter, -80 dBm typical receive sensitivity
- Frequency 2,402 ~ 2,480 MHz
- FHSS/GFSK modulation, 79 channels at 1-MHz intervals
- Secure communications, 128-bit encryption
- Error correction for guaranteed packet delivery
- Configuration via the local UART and over-the-air RF
- Auto-connect master, I/O pin (DTR), and character-based trigger modes

The module's moisture sensitivity level (MSL) is 1. [Table 2-1](#) shows the module's size and weight.

TABLE 2-1: MODULE SIZE & WEIGHT

Parameter	RN41XVC RN42XVP	RN41XVU RN42XVU	Units
Size	24.4 x 29.9	24.4 x 29.0	In.
Weight	5.5	5.5	g

[Table 2-2](#), [Table 2-3](#), [Table 2-4](#), [Table 2-5](#), [Table 2-6](#), and [Table 2-7](#) provide detailed specifications for the module.

TABLE 2-2: ENVIRONMENTAL CONDITIONS

Parameter	Value
Temperature Range (Operating)	-40° C ~ 85° C
Temperature Range (Storage)	-40° C ~ 85° C
Relative Humidity (Operating)	≤ 90%
Relative Humidity (Storage)	≤ 90%

TABLE 2-3: RN41XV & RN42XV DIGITAL I/O CHARACTERISTICS

3.0 V ≤ VDD ≤ 3.3 V	Min.	Typ.	Max.	Units
Input Logic Level Low	-0.4	-	+0.8	V
Input Logic Level High	0.7 VDD	-	VDD + 0.4	V
Output Logic Level Low	-	-	0.2	V
Output Logic Level High	VDD - 0.2	-	-	V
All I/O pins (Except Reset) Default to Weak Pull Down	+0.2	+1.0	+5.0	μA

TABLE 2-4: RN41XV ELECTRICAL CHARACTERISTICS

Parameter	Min.	Typ.	Max.	Units
Supply Voltage (DC)	3.0	3.3	3.6	V
RX Supply Current		35	60	mA
TX Supply Current		65	100	mA
Average Power Consumption				
Standby/Idle (Default Settings)		25		mA
Connected (Normal Mode)		30		mA
Connected (Low-Power Sniff)		8		mA
Standby/Idle (Deep Sleep Enabled)	250	2.5		mA

TABLE 2-5: RN42XV ELECTRICAL CHARACTERISTICS

Parameter	Min.	Typ.	Max.	Units
Supply Voltage (DC)	3.0	3.3	3.6	V
Average Power Consumption				
Radio On (Discovery or Inquiry Window Time), <i>Note 1</i>		40		mA
Connected Idle (No Sniff)		25		mA
Connected Idle (Sniff 100 ms)		12		mA
Connected with Data Transfer	40	45	50	mA
Deep Sleep Idle Mode		26		μ A

Note 1: In slave mode, there are bursts of radio on time that vary with the inquiry windows. The average current depends on how you set the inquiry window.

TABLE 2-6: RN41XV RADIO CHARACTERISTICS

Parameter	Frequency (GHz)	Min.	Typ.	Max.	Bluetooth Specification	Units
Sensitivity at 0.1% BER	2.402	-	-80	-86	≤ -70	dBm
	2.441	-	-80	-86		dBm
	2.480	-	-80	-86		dBm
RF Transmit Power	2.402	15.0	16.0		≤ 20	dBm
	2.441	15.0	16.0			dBm
	2.480	15.0	16.0			dBm
Initial Carrier Frequency Tolerance	2.402	-	5	75	75	kHz
	2.441	-	5	75		kHz
	2.480	-	5	75		kHz
20 dB Bandwidth for Modulated Carrier		-	900	1,000	$\leq 1,000$	kHz
Drift (Five Slots Packet)		-	15	-	40	kHz
Drift Rate		-	13	-	20	kHz
$\Delta f_{1_{avg}}$ Maximum Modulation	2.402	140	165	175	> 140	kHz
	2.441	140	165	175		kHz
	2.480	140	165	175		kHz
$\Delta f_{2_{avg}}$ Minimum Modulation	2.402	140	190	-	115	kHz
	2.441	140	190	-		kHz
	2.480	140	190	-		kHz

TABLE 2-7: RN42XV RADIO CHARACTERISTICS

Parameter	Frequency (GHz)	Min.	Typ.	Max.	Bluetooth Specification	Units
Sensitivity at 0.1% BER	2.402	-	-80	-86	≤ -70	dBm
	2.441	-	-80	-86		dBm
	2.480	-	-80	-86		dBm
RF Transmit Power	2.402	0	2	4	≤ 4	dBm
	2.441	0	2	4		dBm
	2.480	0	2	4		dBm
Initial Carrier Frequency Tolerance	2.402	-	5	75	75	kHz
	2.441	-	5	75		kHz
	2.480	-	5	75		kHz
20 dB Bandwidth for Modulated Carrier		-	900	1,000	≤ 1,000	kHz
Drift (Five Slots Packet)		-	15	-	40	kHz
Drift Rate		-	13	-	20	kHz
$\Delta f_{1\text{avg}}$ Maximum Modulation	2.402	140	165	175	> 140	kHz
	2.441	140	165	175		kHz
	2.480	140	165	175		kHz
$\Delta f_{2\text{avg}}$ Minimum Modulation	2.402	140	190	-	115	kHz
	2.441	140	190	-		kHz
	2.480	140	190	-		kHz

Figure 2-1 shows the module's dimensions and Table 2-8 describes the pins.

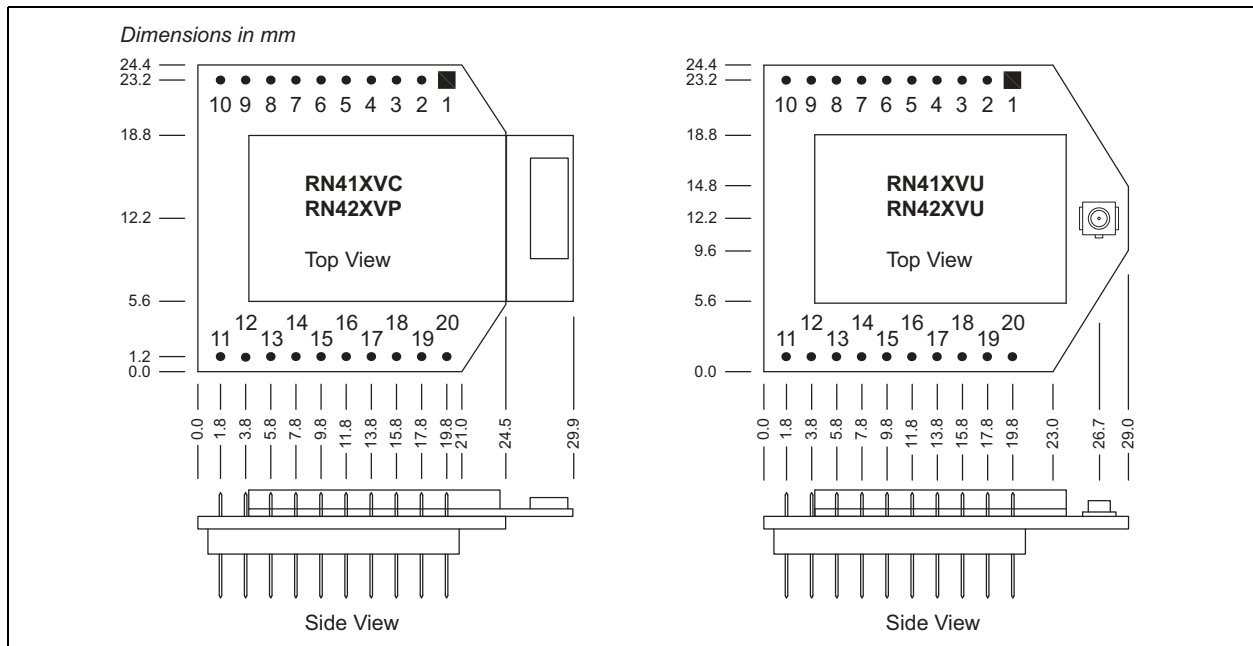
FIGURE 2-1: RN41XV & RN42XV DIMENSIONS

TABLE 2-8: PIN DESCRIPTION (PART 1 OF 2)

Pin Number	Signal Name	Description	Optional Function	Direction
1	VDD_3V3	3.3 V regulated power input to the module.		Power
2	TXD	UART TX, 8 mA drive, 3.3-V tolerant.		From module
3	RXD	UART RX, 3.3 V tolerant.		To module
4	GPIO7	GPIO, 24 mA drive, 3.3 V tolerant/ADC input.		I/O
5	RESET_N	<i>Optional</i> module reset signal (active low), 100 k pull up, apply pulse of at least 160 μ s, 3.3 V tolerant.		Input
6	GPIO6	GPIO, 24 mA drive, 3.3-V tolerant/ADC input.	Data TX/RX	From module
7	GPIO9	GPIO, 24 mA drive, 3.3-V tolerant/ADC input.		I/O
8	GPIO4	GPIO, 24 mA drive, 3.3 V tolerant/ADC input.		I/O
9	GPIO11	GPIO, 8 mA drive, 3.3 V tolerant.		I/O
10	GND	Ground.		Ground
11	GPIO8	GPIO, 8 mA drive, 3.3-V tolerant. The RN41XV and RN42XV drive GPIO8 high on powerup, which overrides software configured powerup values, on GPIO8.		I/O
12	RTS	UART RTS flow control, 8 mA drive, 3.3 V tolerant.		From module
13	GPIO2	GPIO, 24 mA drive, 3.3 V tolerant/ADC input.		I/O
14	Not Used	No connect.		No Connect
15	GPIO5	GPIO, 24 mA drive, 3.3 V tolerant/ADC input.		I/O

TABLE 2-8: PIN DESCRIPTION (PART 2 OF 2)

Pin Number	Signal Name	Description	Optional Function	Direction
16	CTS	UART CTS flow control, 3.3 V tolerant.		To module
17	GPIO3	GPIO, 24 mA drive, 3.3 V tolerant/ADC input.		I/O
18	GPIO7	GPIO, 24 mA drive, 3.3 V tolerant/ADC input.		I/O
19	AIO0			
20	AIO1			

3.0 TYPICAL APPLICATION SCHEMATIC

Figure 3-12 shows a typical application schematic. Because the RN41XV and RN42XV are functionally compatible, this diagram applies to both modules. The

RN-XV-EK evaluation kit is shown as a reference. The RN-XV-EK evaluation board provides a 2 x 10 (2-mm) socket for both the RN41XV and RN41XV modules. The design offers USB/serial connection to the on-board UART, a reset switch (pin 5), and switch to control GPIO4 (pin 8).

FIGURE 3-1: APPLICATION SCHEMATIC, Note 1

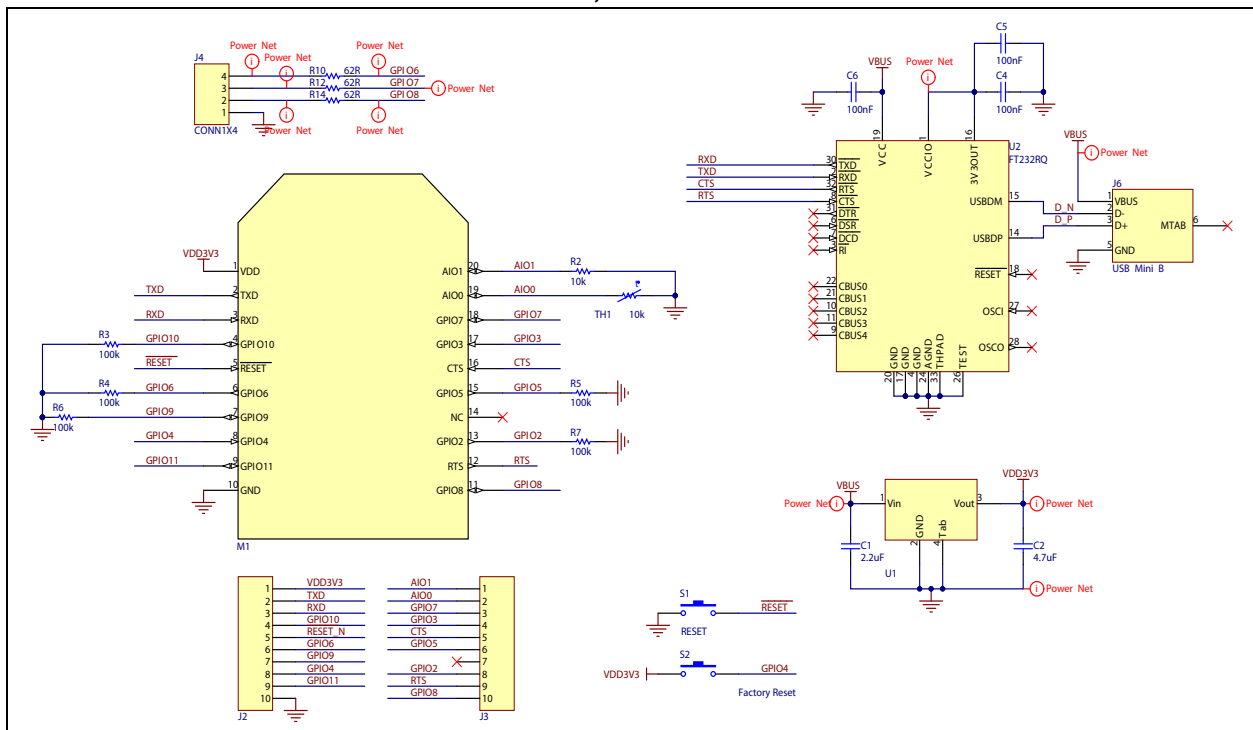

Note 1: The RN-XV-EK evaluation kit is shown as a reference.

4.0 DESIGN CONCERNS

The following sections provide information on designing with the RN41XV and RN42XV module, including radio interference, factory reset, connection status, etc.

4.1 Powering the Module

Apply ONLY 3.3 V \pm 10% regulated power to pin 1 (VDD) and pin 10 (ground). The module does not have an on-board voltage regulator and MUST be powered from a regulated 3.3 V power supply.

4.2 Reset Circuit

The RN41XV and RN42XV modules contain a 1k Ω pull-up to VCC, and the reset polarity is active low. The module's reset pin has an optional power-on-reset circuit with a delay, which should only be required if the input power supply has a very slow ramp or tends to bounce or have instability on power up. Often a micro-controller or embedded CPU I/O is available to gener-

ate the reset once power is stable. If not, designers can use one of the many low-cost power supervisor chips currently available, such as the MCP809, MCP102/121, and Torex XC61F.

4.3 Factory Reset Using GPIO4

Roving Networks recommends that designers connect GPIO4 (pin 8) to a switch, jumper, or resistor so it can be accessed. This pin can be used to reset the module to its factory default settings, which is critical in situations where the module has been misconfigured. To reset the module to the factory defaults, GPIO4 should be high on power-up and then toggle low, high, low, high with a 1 second wait between the transitions.

4.4 Connection Status

The RN41XV and RN42XV modules have an on-board green LED to indicate the connection status. The connection status LED is located in the lower right corner of the module.

TABLE 4-1: CONNECTION STATUS LED

LED Status	Description
Blink at 1 Hz	The module is discoverable and waiting for a connection.
Blink at 10 Hz	The module is in command mode.
Solid	The module is connected to another device over Bluetooth.

5.0 COMPLIANCE INFORMATION

Table 5-1 and Table 5-2 describe the RN41XV and RN42XV module's compliance information, respectively.

TABLE 5-1: RN41XV COMPLIANCE INFORMATION

Category	Country	Standard
Radio	USA FCC ID:	FCC CFR47 Part 15 C, para 15.247
		T9J-R41-1
	Europe	EN 300 328-1
		EN 300 328-2 2.4GHz
	Canada IC Canada ID:	IC RSS-210 low power comm. device
		6514A-RN411
EMC	USA	FCC CFR47 Part 15 subclass B
	Europe	EN 55022 Class B radiated
		EN61000-4-2 ESD immunity
		EN61000-4-3 radiated field
		EN61000-4-6 RF immunity
		EN61000-4-8 power magnetic immunity
Bluetooth	LISTED	B013180
Environmental	RoHS	RoHS compliant

TABLE 5-2: RN42XV COMPLIANCE INFORMATION

Category	Country	Standard
Radio	USA	FCC Part 15 Subpart B: 2008 Class B
		FCC CRF Title 47 Part 15 Subpart C
	FCC ID:	T9J-RN42
	Europe	ETSI EN 301 489-1 V1.8.1
		ETSI EN 301 489-17 V2.1.1
		ETSI EN 300 328 V1.7.1
	Canada	IC RSS-210 low power comm. device
Certification Number:	6514A-RN42	
EMC	USA	FCC CFR47 Part 15 subclass B
	Europe	EN 55022 Class B radiated
		EN61000-4-2 ESD immunity
		EN61000-4-3 radiated field
		EN61000-4-6 RF immunity
		EN61000-4-8 power magnetic immunity
Bluetooth	BQB LISTED	B014867- SPP and DUN profiles
Environmental	RoHS	RoHS compliant

6.0 ORDERING INFORMATION

Table 6-1 provides ordering information.

TABLE 6-1: ORDERING INFORMATION

Part Number	Description
RN41XVC-I/RM	RN41 XV footprint, chip antenna.
RN41XVU-I/RM	RN41 XV footprint, U.FL. antenna.
RN42XVP-I/RM	RN42 XV footprint, PCB antenna.
RN42XVU-I/RM	RN42 XV footprint, U.FL. antenna.
For other configurations, contact Roving Networks directly.	

Go to <http://www.rovingnetworks.com> for current pricing and a list of distributors carrying Roving Networks products.

Table 6-2 provides information on related products that work with the RN41XV and RN42XV.

TABLE 6-2: RELATED PRODUCTS

Part Number	Description
RN-XV-EK	Evaluation platform for the RN41XV or RN42XV module. Used for learning and demonstrating WiFly commands and Roving Networks hardware capabilities.
RN-XV-RD2	Evaluation platform for the RN41XV or RN42XV module. Contains 2 10-amp, 250 V relays.

Copyright © 2012 Roving Networks. All rights reserved. Roving Networks is a registered trademark of Roving Networks. Apple Inc., iPhone, iPad, iTunes, Made for iPhone are registered trademarks of Apple Computer.

Roving Networks reserves the right to make corrections, modifications, and other changes to its products, documentation and services at any time. Customers should obtain the latest relevant information before placing orders and should verify that such information is current and complete.

Roving Networks assumes no liability for applications assistance or customer's product design. Customers are responsible for their products and applications that use Roving Networks components. To minimize customer product risks, customers should provide adequate design and operating safeguards.

Roving Networks products are not authorized for use in safety-critical applications (such as life support) where a failure of the Roving Networks product would reasonably be expected to cause severe personal injury or death, unless officers of the parties have executed an agreement specifically governing such use.

Roving Networks, Inc.
102 Cooper Court
Los Gatos, CA 95032
+1 (408) 395-5300
www.rovingnetworks.com