

PRODUCT DATA DRAWING

REVISION HISTORY			
REV	DESCRIPTION	DATE	APPROVED
01	PRELIMINARY	08/11	FED
-	REL. NRN 41940	11/27/17	STW

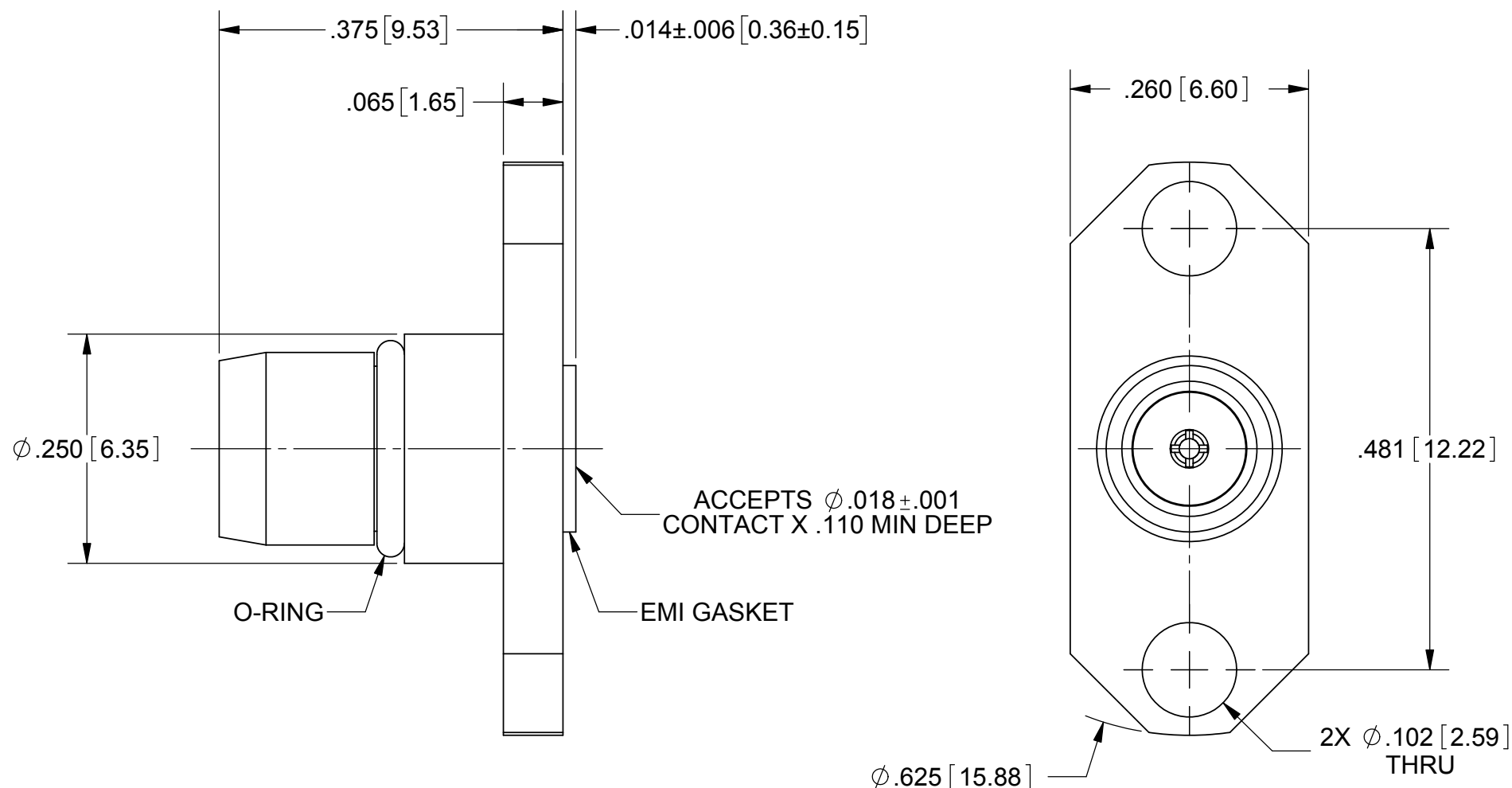

MATERIAL:

- BODY:** STAINLESS STEEL PER AMS-5640, ALLOY UNS S30300, TYPE 1 OR ASTM A582, TYPE 303, CONDITION A.
- CONTACT:** BERYLLIUM COPPER PER ASTM B196, ALLOY No. UNS C17300, TD04.
- INSULATOR:** PTFE PER ASTM D1710, TYPE I, GRADE 1, CLASS B
- O-RING:** FLUOROSILICONE RUBBER PER SAE-AMS-R-25988, CLASS 1, TYPE I.
- EMI GASKET:** CONDUCTIVE SILVER/SILICONE ELASTOMER PER MIL-DTL-83528.

FINISH:

- BODY:** PASSIVATED PER AMS 2700.
- CONTACT:** GOLD PER ASTM B488, TYPE II, CODE C, CLASS 1.27, OVER NICKEL PER AMS-QQ-N-290, CLASS 1, .00005" MIN.

PERFORMANCE:

- IMPEDANCE:** 50 OHMS
- FREQ. RANGE:** DC TO 18.0 GHz
- VSWR:** 1.04+.006*F (F IN GHz) DC TO 18.0 GHz
- INSERTION LOSS:** .03 X SQRT(F(F IN GHz))

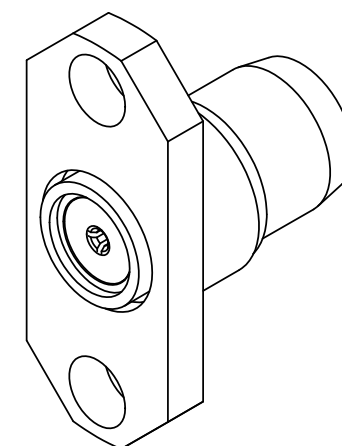

MATERIAL: SEE NOTES	DIMENSIONS ARE IN INCHES TOLERANCES: FRACTIONAL: ±1/64 ANGULAR: X° ±1'0" X"X' ±15'	UNLESS OTHERWISE SPECIFIED 1) ALL DIMENSIONS ARE IN INCHES (MILLIMETERS) 2) ALL DIMENSIONS ARE AFTER PLATING. 3) BREAK CORNERS & EDGES .005 R. MAX. 4) CHAM. 1ST & LAST THREADS. 5) SURFACE ROUGHNESS 63-MIL-STD-10. 6) DIA.'S ON COMMON CENTERS TO BE CONCENTRIC WITHIN .005 T.I.R. 7) REMOVE ALL BURRS	SV Microwave, Inc. 2400 Centrepark West Drive, Suite 100 West Palm Beach, FL 33409
FINISH: SEE NOTES	DECIMAL: X ±.030 .XX ±.010 .XXX ±.005	INTERPRET DIMENSIONS AND TOLERANCES PER ASME Y14.5M - 1994	TITLE: BMA 2-HOLE FLANGE MOUNT PLUG RECEPTACLE ACCEPTS Ø.018±.001 PIN
SURFACE AREA: N/A	THIRD ANGLE PROJECTION	DRAWN: FED 08/19/11 CHECKED: JMC 11/22/17 APPROVED: STW 11/27/17	SIZE: B CAGE CODE: 95077 DWG. NO.: SF1711-60013
<p>PROPRIETARY</p> <p>THE INFORMATION CONTAINED IN THIS DRAWING IS THE SOLE PROPERTY OF SV MICROWAVE, INC. ANY REPRODUCTION IN PART OR AS A WHOLE WITHOUT THE WRITTEN PERMISSION OF SV MICROWAVE, INC IS PROHIBITED.</p>		SCALE: 6:1	SHEET 1 OF 1