

THIS DRAWING IS UNPUBLISHED. RELEASED FOR PUBLICATION  
 © COPYRIGHT BY TYCO ELECTRONICS CORPORATION. ALL RIGHTS RESERVED.

| LOC |     | DIST                      |         | REVISIONS |      |  |  |
|-----|-----|---------------------------|---------|-----------|------|--|--|
| P   | LTR | DESCRIPTION               | DATE    | DWN       | APVD |  |  |
| GP  | 00  |                           |         |           |      |  |  |
|     | 01  | REVISED PER ECO-07-008008 | 10APR07 | JDP       | CWR  |  |  |

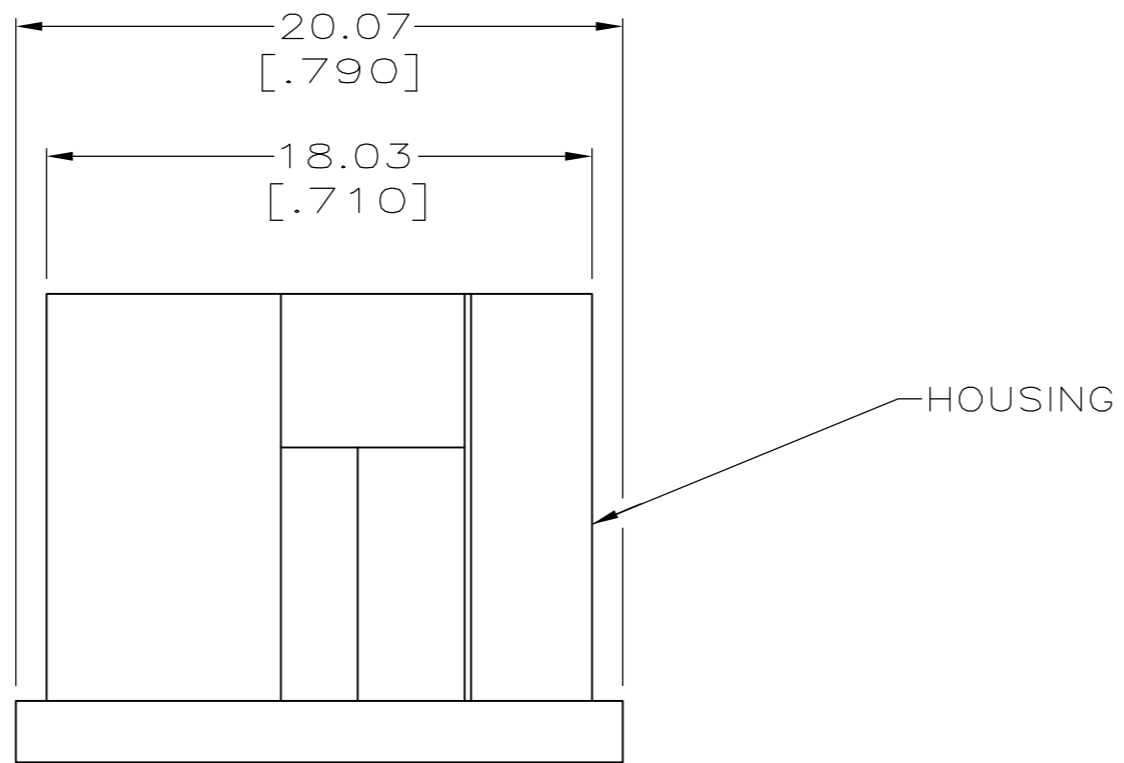

- ① HOUSING: NYLON, UL 94V-0 RATED, BLACK.
- ② CONTACTS & GROUND CONTACT: 2.54μm [.000100] MIN TIN OVER 1.27μm [.000050] MIN NICKEL.
- ③ ACCEPTS #2 SELF-TAPPING SCREW, .250 LONG REF.
- ④ CONTACT AND GROUND CONTACT: BRASS.

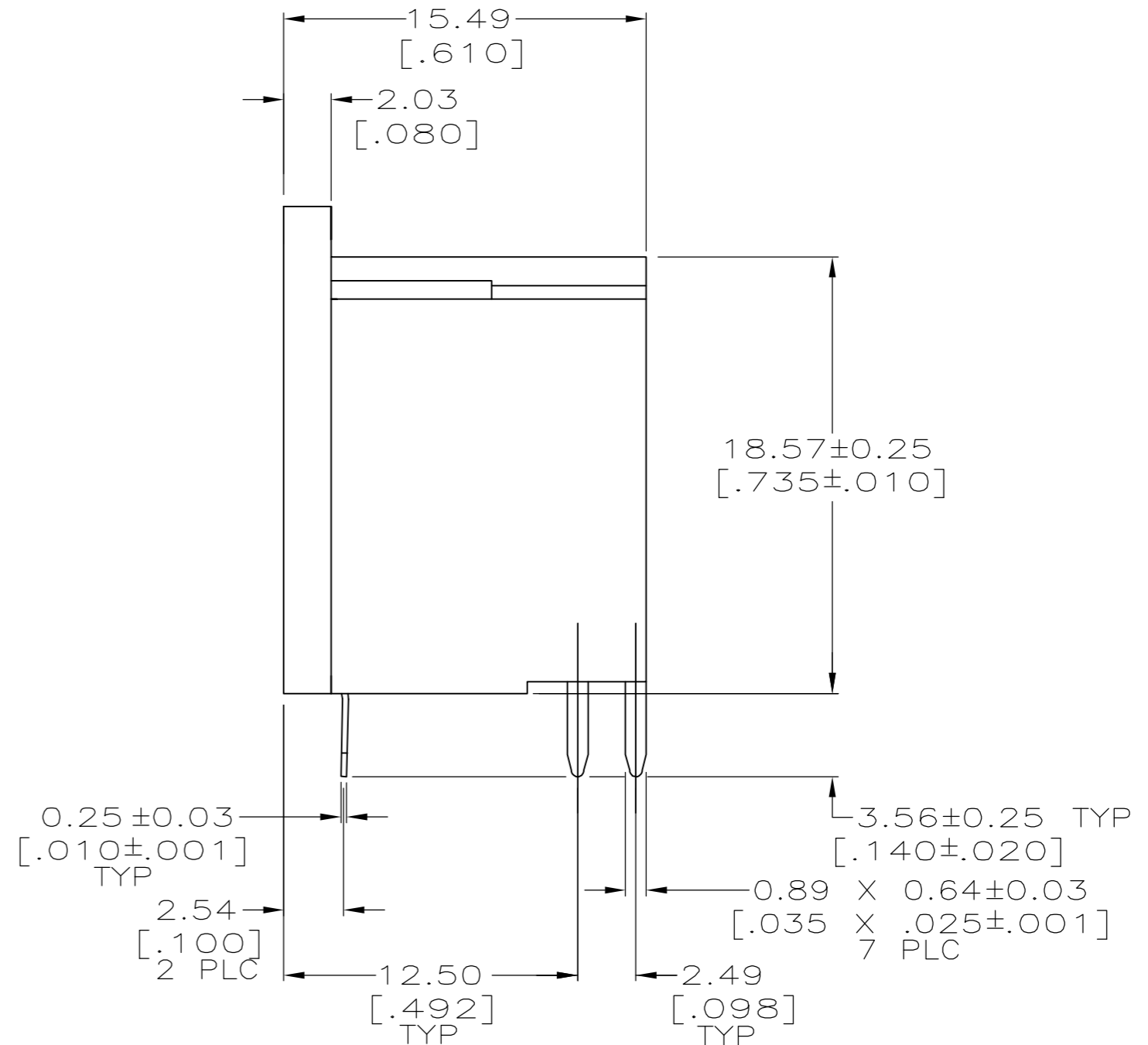
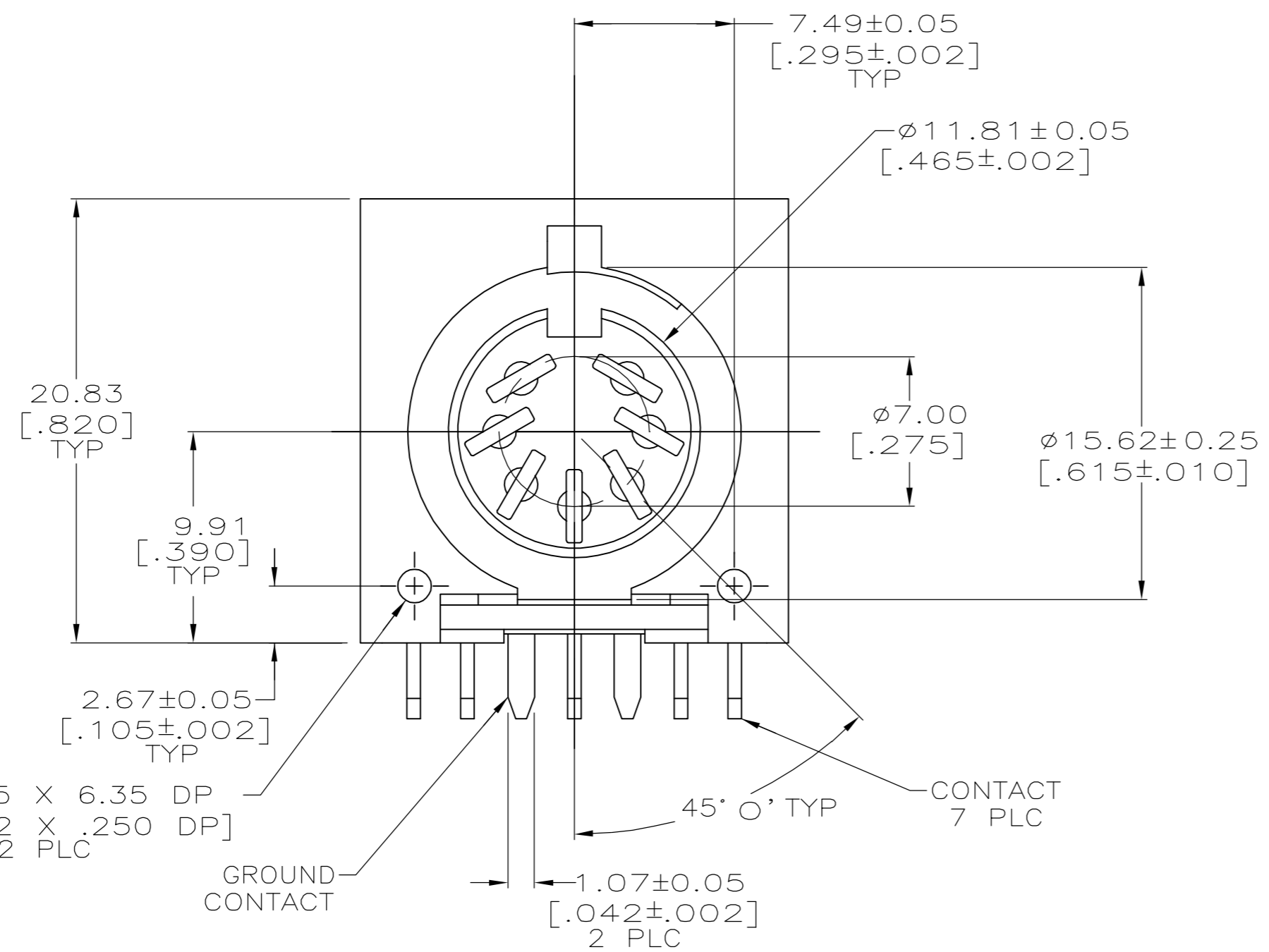

③ φ1.60±0.05 X 6.35 DP  
 [.063±.002 X .250 DP]  
 2 PLC

5211510-1  
 PART NUMBER

|  |  |                                |   |                      |
|--|--|--------------------------------|---|----------------------|
| THIS DRAWING IS A CONTROLLED DOCUMENT. |  | DWN L. VARELA - DOCK5 11-11-04 | Tyco Electronics Corporation<br>Harrisburg, PA 17105-3608   |                      |
| DIMENSIONS: mm [INCHES]                |  | CHK C.ROHDE 11-11-04           |   |                      |
| TOLERANCES UNLESS OTHERWISE SPECIFIED: |  | APVD M. WALMSLEY 11-11-04      | NAME RECEPTACLE ASSY, RIGHT ANGLE, 7 POSITION, CIRCULAR DIN |                      |
| 0 PLC ± -                              |  | PRODUCT SPEC 108-10047         | SIZE A2   |                      |
| 1 PLC ± -                              |  | APPLICATION SPEC 114-40025     | CAGE CODE 00779   | DRAWING NO C=5211510 |
| 2 PLC ± 0.13[.005]                     |  |                                | RESTRICTED TO -   |                      |
| 3 PLC ± -                              |  |                                | SCALE 4:1   | SHEET 1 of 1         |
| 4 PLC ± -                              |  |                                | REV 01  |                      |
| ANGLES ± 0' 30'                        |  |                                |   |                      |
| FINISH                                 |  |                                |   |                      |
| MATERIAL                               |  |                                |   |                      |