

This drawing involves proprietary design rights of Tyco Electronics Corporation, and all design, manufacture, reproduction, use and sale rights regarding the same are expressly reserved. It is submitted for a specific purpose and the recipient by accepting this drawing, assumes custody and control and agrees to take reasonable precautions; (a) that this drawing will not be copied and reproduced, in whole or in part, or its contents revealed in any manner, or to any person except to meet the purpose for which it was delivered and (b) that any special features peculiar to this design will not be incorporated in other projects without the expressed written permission of Tyco Electronics Corporation.

REVISIONS			
EC	REV	DESCRIPTION	DATE
OS1Q-0135-05	A	NEW RELEASE	15APR05

5. MODULE INFORMATION

CONNECTOR	TYCO PART NUMBER	ELCON PART NUMBER	CATALOG MODULE #	QTY	SIZE NO.	CONTACT QTY	MATING PIN	MAX. CURRENT (PER CONTACT)	CONTACT SPACING	VOLTAGE RATING*
PIN	6766004-1	479-1169-10100A	FP1151	4	8	4	1.25 X 7.00 [.049 X .276]	35 AMPERES	7.50 [1.295]	250 VOLTS
			FP1515	2	ACTIVATED RIGHT ANGLE GUIDE SOCKET					
			FP1817	1	8	4	1.25 X 7.00 [.049 X .276]	35 AMPERES	7.50 [1.295]	250 VOLTS
22	24	.64 [0.025] SQ.			3 AMPERES	2.50 [0.098]	125 VOLTS			

*IAW IEC-950

NOTES: UNLESS OTHERWISE SPECIFIED.

- PART NUMBER CHANGES AND OR DESIGN CHANGES AFFECTING ITEM INTERCHANGEABILITY REQUIRE PRIOR ELCON APPROVAL AND AUTHORIZATION BY REVISION TO THIS DRAWING.
- MATERIALS:
 INSULATORS: THERMOPLASTIC, GLASS REINFORCED, COLOR BLACK, UL94V-0 FLAMMABILITY RATED.
 SOLDER SIGNAL PIN: BRASS ALLOY.
 POWER CONTACTS: PHOSPHOR-BRONZE ALLOY, COPPER ALLOY.
 CROWN BANDS: BERYLLIUM-COPPER ALLOY.
 GUIDE PIN: BRASS-COPPER ALLOY.
- FINISHES:
 CONTACTS: GOLD PLATED PER TYCO SPEC 112-162-5, .00076 [0.00030] MIN THICK OVER NICKEL PER TYCO SPEC 112-25-2, .00130 [0.00050] MIN THICK
 SOLDER TAILS: TIN PLATED PER LEAD FREE TYCO SPEC 112-65-1, MATT FINISH .0030 TO .0043 [0.00120 TO .000170] THICKNESS
- ITEMS PROVIDED TO THIS SPECIFICATION TO BE PERMANENTLY IDENTIFIED PER THE FOLLOWING IDENTIFIER:

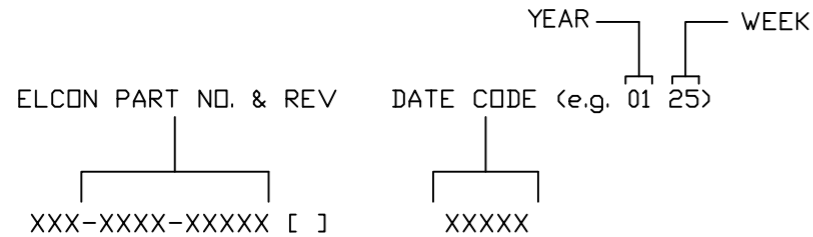

 THIRD ANGLE PROJECTION UNLESS OTHERWISE SPECIFIED DIMENSIONS ARE IN METRIC [INCHES] TOLERANCES ANGLES ± .5° DECIMALS .XX ± .25 [.010] .X ± .5 [.020]	DRAWN M.C.CANT	DATE 15APR05	Tyco Electronics Corporation Menlo Park, Ca 94025
	CHECKED		
	APPROVED		
	APPROVED D. CHAU	03MAY05	SIZE B
	DCA APPROVED M. ALIM	03MAY05	DWG NUMBER C = 6766004
	ACAD FILE NUMBER C6766004A.DWG		REV. A
		DWG SCALE 1 = 1	SH 1 OF 3

This drawing involves proprietary design rights of Tyco Electronics Corporation, and all design, manufacture, reproduction, use and sale rights regarding the same are expressly reserved. It is submitted for a specific purpose and the recipient by accepting this drawing, assumes custody and control and agrees to take reasonable precautions; (a) that this drawing will not be copied and reproduced, in whole or in part, or its contents revealed in any manner, or to any person except to meet the purpose for which it was delivered and (b) that any special features peculiar to this design will not be incorporated in other projects without the expressed written permission of Tyco Electronics Corporation.

REVISIONS

EC	REV	DESCRIPTION	DATE
		SEE SHEET 1	

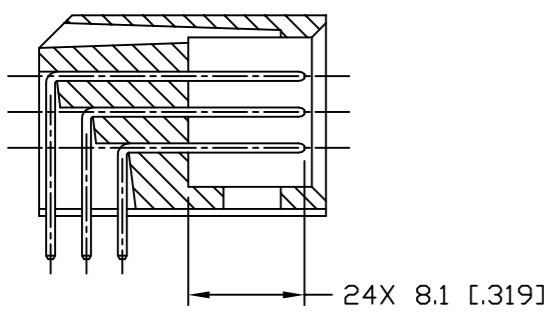

SECTION A-A

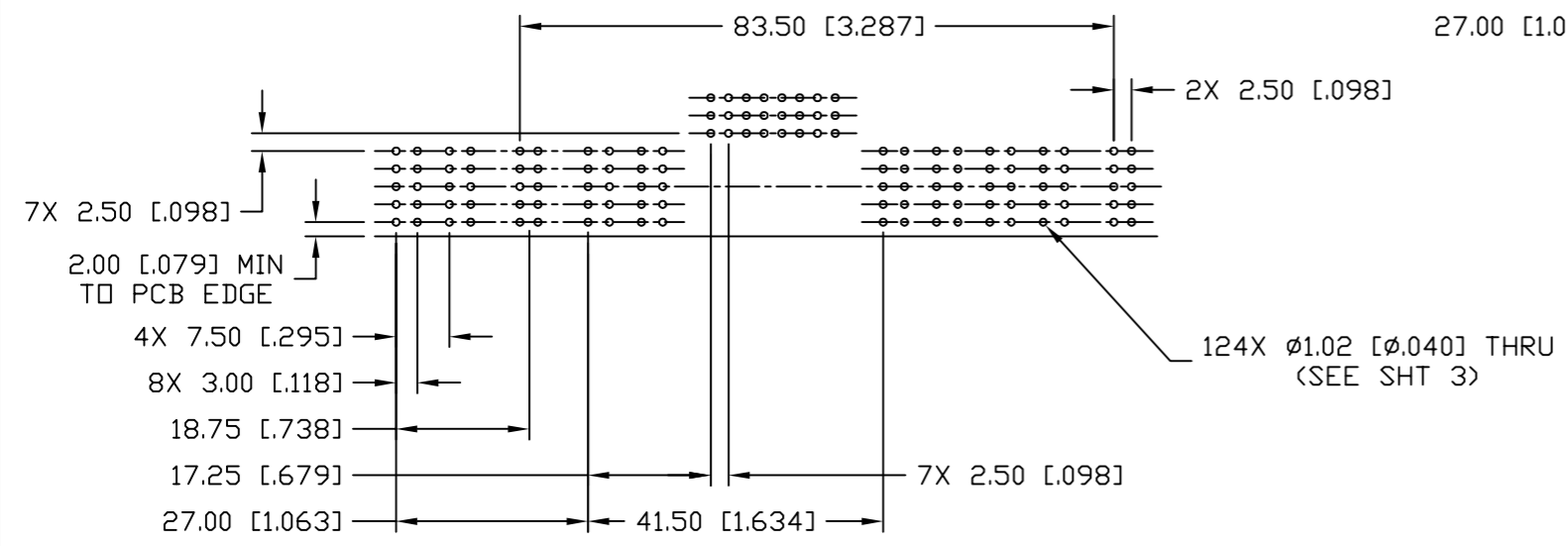
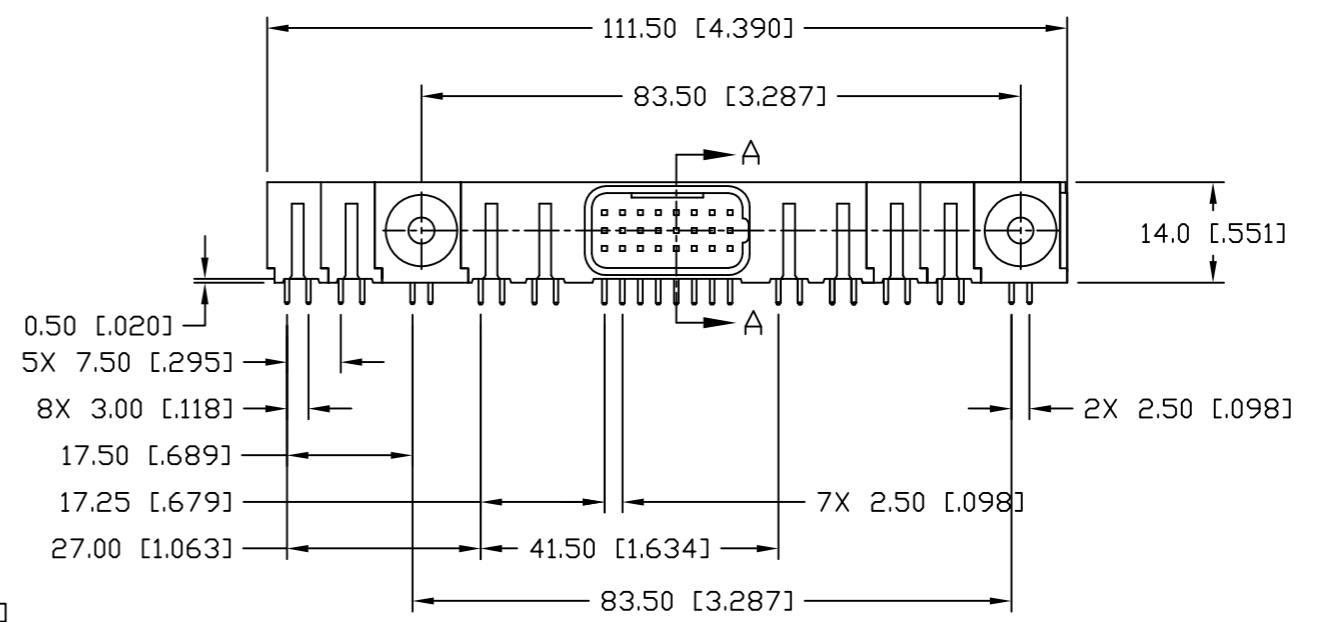
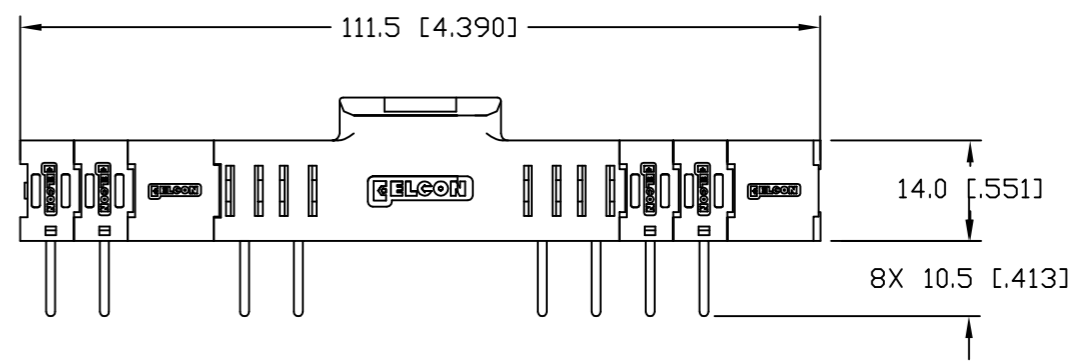
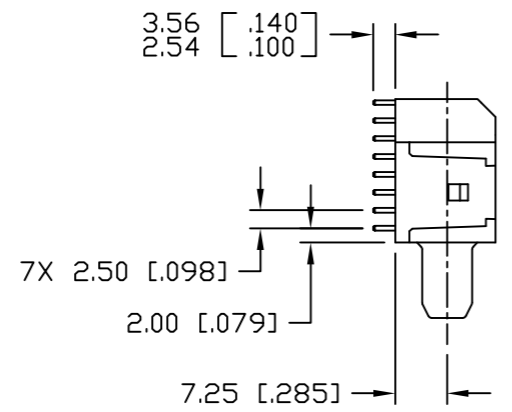

PRINTED CIRCUIT LAYOUT

<p>THIRD ANGLE PROJECTION</p> <p>UNLESS OTHERWISE SPECIFIED DIMENSIONS ARE IN METRIC [INCHES]</p> <p>TOLERANCES</p> <p>ANGLES ± .5°</p> <p>DECIMALS</p> <p>.XX ± .25 [.010]</p> <p>.X ± .5 [.020]</p>	<p>MM OR MM [INCH]</p> <p>DRAWN M.C.CANT</p>	<p>DATE 15APR05</p>	<p>tyco Tyco Electronics Corporation Electronics Menlo Park, Ca 94025</p> <p>ELCON</p>
	<p>CHECKED</p>	<p>TITLE</p> <p>PIN CONNECTOR, FLATPAQ RIGHT ANGLE, SOLDER TAILS PN: 479-1169-10100A</p>	
	<p>APPROVED</p>	<p>APPROVED</p> <p>D. CHAU 03MAY05</p>	<p>SIZE DWG NUMBER</p> <p>B C = 6766004</p>
	<p>DCA APPROVED</p> <p>M. ALIM 03MAY05</p>	<p>ACAD FILE NUMBER C6766004A.DWG</p>	<p>REV. A</p>
<p>DWG SCALE 1=1 SH 2 OF 3</p>			

This drawing involves proprietary design rights of Tyco Electronics Corporation, and all design, manufacture, reproduction, use and sale rights regarding the same are expressly reserved. It is submitted for a specific purpose and the recipient by accepting this drawing, assumes custody and control and agrees to take reasonable precautions; (a) that this drawing will not be copied and reproduced, in whole or in part, or its contents revealed in any manner, or to any person except to meet the purpose for which it was delivered and (b) that any special features peculiar to this design will not be incorporated in other projects without the expressed written permission of Tyco Electronics Corporation.

REVISIONS			
EC	REV	DESCRIPTION	DATE
		SEE SHEET 1	

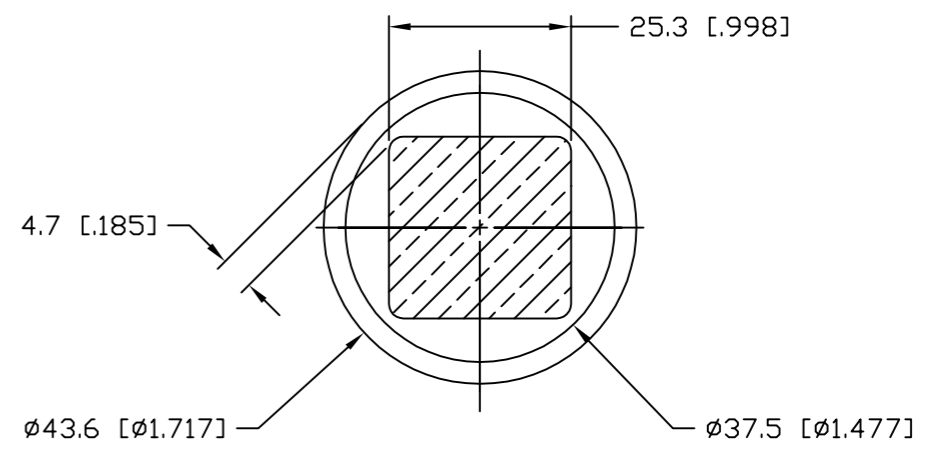
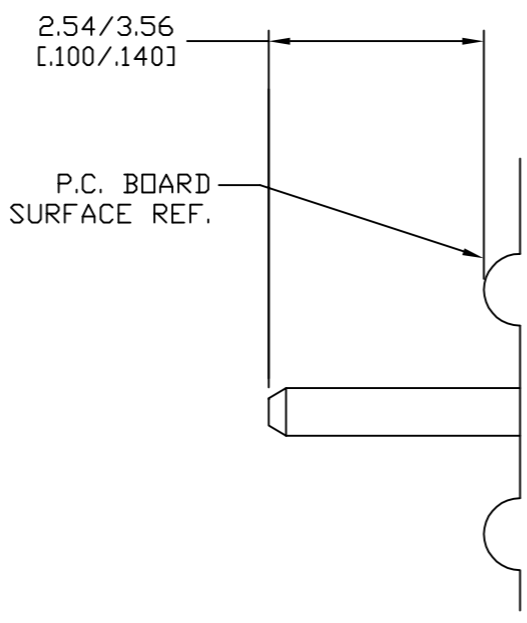

SOLDER TERMINATION AREA

SCALE: 40 : 1
 RECOMMENDED PRINTED CIRCUIT HOLE
 SOLDER OR COMPLIANT PRESS FIT
 FINISHED HOLE: $\phi 1.02$ [.040] $\pm .08$ [.003]
 DRILLED HOLE: $\phi 1.15$ [.0453] $\pm .013$ [.0005]
 COPPER PLATE: .025 [.0010] MINIMUM (PER SURFACE)
 TIN PLATE: .008 [.0003] MINIMUM (PER SURFACE)

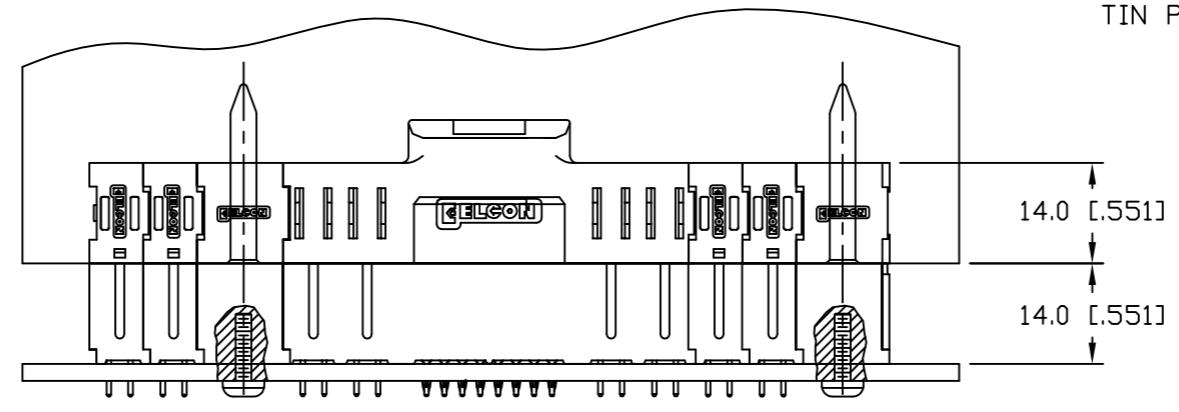
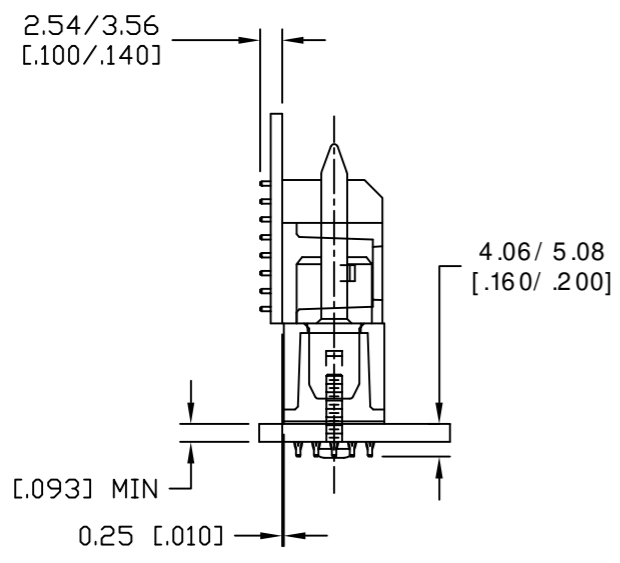

MATED CONDITION

← MM INCH → OR MM [INCH] THIRD ANGLE PROJECTION UNLESS OTHERWISE SPECIFIED DIMENSIONS ARE IN METRIC [INCHES] TOLERANCES ANGLES $\pm .5^\circ$ DECIMALS .XX $\pm .25$ [.010] .X $\pm .5$ [.020]	DRAWN M.C.CANT	DATE 15APR05	 Tyco Electronics Corporation Menlo Park, Ca 94025 	TITLE USER INFORMATION SOLDER TAIL TERMINATION AND MATED CONDITION	
	CHECKED	APPROVED			APPROVED D. CHAU 03MAY05
	APPROVED M. ALIM 03MAY05	APPROVED DCA APPROVED	APPROVED D. CHAU 03MAY05	SIZE B	DWG NUMBER C = 6766004
	ACAD FILE NUMBER C6766004A.DWG	DWG SCALE 1 = 1	SH 3 OF 3	REV. A	