

XC1AC117

Limit switch, Limit switches XC Standard, XC1AC, reinforced roller lever, 1C/O



Main

Range of Product	OsiSense XC
Series name	Special format
Product or Component Type	Limit switch
Product Specific Application	Materials handling
Device short name	XC1AC
Sensor design	-
Body type	Fixed
Head type	Plunger head
Material	Metal
Fixing Mode	By the body
Movement of operating head	Linear
Type of operator	Spring return roller lever metal reinforced
Switch actuation	By 30° cam
Type of approach	Lateral approach, 2 directions
Electrical connection	Screw-clamp terminals 1 x 0.5...1 x 2.5 mm ²
Cable entry	3 entries tapped for Pg 13.5 cable gland 0.35...0.47 in (9...12 mm)
Number of poles	1
Contacts type and composition	1 C/O
Contact operation	Slow-break
Number of steps	1
Positive opening	Without
Minimum force for tripping	29 N

Complementary

Contacts insulation form	Za
Maximum actuation speed	3.28 Ft/S (1 m/s) from left 1.64 ft/s (0.5 m/s) from right
[Ithe] conventional enclosed thermal current	10 A
[Ui] rated insulation voltage	500 V ACIEC 60947-5-1 500 V ACNF C 20-040 600 V DCIEC 60947-5-1 600 V DCNF C 20-040 600 V ACCSA C22.2 No 14 600 V DCCSA C22.2 No 14
Maximum resistance across terminals	8 mOhm
Short-circuit protection	10 A cartridge fuse gG

The information provided in this documentation contains general descriptions and/or technical characteristics of the performance of the products contained herein. This documentation is not intended as a substitute for and is not to be used for determining suitability or reliability of these products for specific user applications. It is the duty of any such user or integrator to perform the appropriate and complete risk analysis, evaluation and testing of the products with respect to the relevant specific application or use thereof. Neither Schneider Electric Industries SAS nor any of its affiliates or subsidiaries shall be responsible or liable for misuse of the information contained herein.

Electrical durability	1000000 Cycles, AC-15 50/60 Hz, inductive, 110 V, 900 VA 60 cyc/mn 0.5 IEC 60947-5-1 appendix C 1000000 Cycles, AC-15 50/60 Hz, inductive, 230 V, 1900 VA 60 cyc/mn 0.5 IEC 60947-5-1 appendix C 1000000 Cycles, AC-15 50/60 Hz, inductive, 48 V, 450 VA 60 cyc/mn 0.5 IEC 60947-5-1 appendix C 1000000 Cycles, DC-13, inductive, 110 V, 100 W 60 cyc/mn 0.5 IEC 60947-5-1 appendix C 1000000 Cycles, DC-13, inductive, 230 V, 95 W 60 cyc/mn 0.5 IEC 60947-5-1 appendix C 1000000 Cycles, DC-13, inductive, 48 V, 100 W 60 cyc/mn 0.5 IEC 60947-5-1 appendix C 3000000 Cycles, AC-15 50/60 Hz, inductive, 110 V, 350 VA 60 cyc/mn 0.5 IEC 60947-5-1 appendix C 3000000 Cycles, AC-15 50/60 Hz, inductive, 230 V, 430 VA 60 cyc/mn 0.5 IEC 60947-5-1 appendix C 3000000 Cycles, AC-15 50/60 Hz, inductive, 48 V, 170 VA 60 cyc/mn 0.5 IEC 60947-5-1 appendix C 3000000 Cycles, DC-13, inductive, 110 V, 40 W 60 cyc/mn 0.5 IEC 60947-5-1 appendix C 3000000 Cycles, DC-13, inductive, 230 V, 33 W 60 cyc/mn 0.5 IEC 60947-5-1 appendix C 3000000 cycles, DC-13, inductive, 48 V, 35 W 60 cyc/mn 0.5 IEC 60947-5-1 appendix C
Mechanical durability	10000000 cycles
Width	3.03 in (77 mm)
Height	5.47 in (139 mm)
Depth	1.73 in (44 mm)
Net Weight	1.31 lb(US) (0.595 kg)
Terminals description ISO n°1	(11-12)NC (13-14)NO

Environment

Shock resistance	95 gn 11 ms IEC 60068-2-27
Vibration resistance	9 gn 10...500 Hz)IEC 60068-2-6
IP degree of protection	IP65 conforming to IEC 60529 IP65 conforming to NF C 20-010
Electrical shock protection class	Class I IEC 61140 Class I NF C 20-030
Ambient Air Temperature for Operation	-13...158 °F (-25...70 °C)
Ambient Air Temperature for Storage	-40...158 °F (-40...70 °C)
Protective treatment	TC
Operating position	Any position
Product Certifications	CSA
Standards	IEC 60337-1 IEC 60947-5-1 CSA C22.2 No 14 VDE 0660-200 EN 60947-5-1



Ordering and shipping details

Category	22449-LIMIT SWITCHES,ACCESSORIES
Discount Schedule	T
GTIN	3389110315141
Nbr. of units in pkg.	1
Package weight(Lbs)	31.75 oz (900.0 g)
Returnability	No
Country of origin	FR

Packing Units

Unit Type of Package 1	PCE
Package 1 Height	2.36 in (6.0 cm)
Package 1 width	6.61 in (16.8 cm)
Package 1 Length	4.57 in (11.6 cm)
Unit Type of Package 2	S02
Number of Units in Package 2	8
Package 2 Weight	16.59 lb(US) (7.524 kg)
Package 2 Height	5.91 in (15.0 cm)
Package 2 width	11.81 in (30.0 cm)
Package 2 Length	15.75 in (40.0 cm)

Offer Sustainability

California proposition 65	WARNING: This product can expose you to chemicals including: Diisononyl phthalate (DINP), which is known to the State of California to cause cancer, and Di-isodecyl phthalate (DIDP), which is known to the State of California to cause birth defects or other reproductive harm. For more information go to www.P65Warnings.ca.gov
REACH Regulation	 REACH Declaration
EU RoHS Directive	Not applicable, out of EU RoHS legal scope
Environmental Disclosure	 Product Environmental Profile

Contractual warranty

Warranty	18 months
----------	-----------

Dimensions

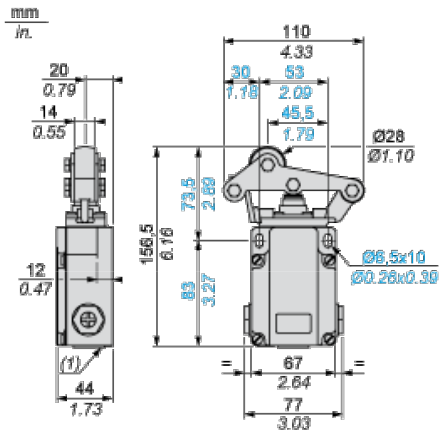

(1) 3 tapped entries for Pg 13.5 cable gland

Adaptator Dimensions for ISO M20 x 1.5

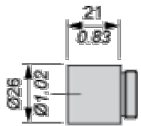

Wiring Diagram

Single-pole CO Slow Break



Characteristics of Actuation

Switch Actuation by 30° Cam

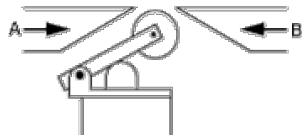

Functionnal Diagram



- (1) Closed
- (2) Open