

Solderless terminals

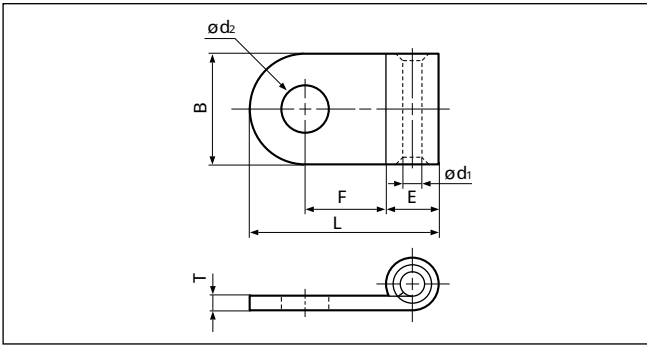

FLAG



Certificate No.: E42024 LR20812

Applicable Wre AWG#(mm ²)	Stud size		Part No.	Standard	Dimensions mm (in.)							Tool No.							Qty/box		
	American	Metric			ϕd_2	B	L	F	E	ϕd_1	T	YG-2216	YG-1614	YG-1210	YG-8S	YG-14S	YA-1	YA-2		YA-4	YA-5
22 to 16 (0.25 to 1.65)	8	4	FG1.25-S4		4.3 (.169)	8.0 (.315)	14.3 (.563)	7.0 (.276)	3.4 (.134)	1.7 (.067)	0.8 (.031)	o				o	o	o			1,000
	10	5	FG1.25-S5		5.3 (.209)	8.0 (.315)	14.3 (.563)	7.0 (.276)													
16 to 14 (1.04 to 2.63)	8	4	FG2-4		4.3 (.169)	9.6 (.378)	16.2 (.638)	7.4 (.291)	4.1 (.161)	2.3 (.091)	0.8 (.031)	o				o	o	o			500
	10	5	FG2-5		5.3 (.209)	9.6 (.378)	16.2 (.638)	7.4 (.291)													
12 to 10 (2.63 to 6.64)	5-6	3.5	FG5.5-3.5		3.7 (.146)	9.6 (.378)	17.8 (.701)	7.4 (.291)	5.6 (.220)	3.4 (.134)	1.0 (.039)		o			o	o	o			500
	8	4	FG5.5-4		4.3 (.169)	9.6 (.378)	17.8 (.701)	7.4 (.291)													
	10	5	FG5.5-5		5.3 (.209)	9.6 (.378)	17.8 (.701)	7.4 (.291)													
8 (6.64 to 10.52)	10	5	FG8-5		5.3 (.209)	12.6 (.496)	23.0 (.906)	9.5 (.374)	7.1 (.280)	4.5 (.177)	1.2 (.047)		o				o	o	o		250
	1/4	6	FG8-6		6.4 (.252)	12.6 (.496)	23.0 (.906)	9.5 (.374)													
	5-16	8	FG8-8		8.4 (.331)	15.5 (.610)	28.5(1.122)	13.6 (.535)													
6 (10.52 to 16.78)	10	5	FG14-5		5.3 (.209)	12.6 (.496)	25.0 (.984)	9.7 (.382)	9.0 (.354)	5.8 (.228)	1.5 (.059)				o		o	o	o	200	
	1/4	6	FG14-6		6.4 (.252)	12.6 (.496)	25.0 (.984)	9.7 (.382)													
4 (16.78 to 26.66)	10	5	FG22-5		5.3 (.209)	14.0 (.551)	28.0(1.102)	9.6 (.378)	11.5 (.453)	7.7 (.303)	1.8 (.071)							o	o	100	
	1/4	6	FG22-6		6.4 (.252)	14.0 (.551)	28.0(1.102)	9.6 (.378)													
	5/16	8	FG22-8		8.4 (.331)	17.5 (.689)	34.0(1.339)	13.8 (.543)													
2 (26.66 to 42.42)	1/4	6	FG38-6		6.4 (.252)	18.2 (.717)	36.0(1.417)	13.6 (.535)	13.3 (.524)	9.4 (.370)	1.8 (.071)							o	o	100	
	5/16	8	FG38-8		8.4 (.331)	18.2 (.717)	36.0(1.417)	13.6 (.535)													
	3/8	10	FG38-10		10.5 (.413)	18.2 (.717)	36.0(1.417)	13.6 (.535)													
1/0 (42.42 to 60.57)	1/4	6	FG60-6		6.4 (.252)	22.0 (.866)	44.0(1.732)	17.6 (.693)	15.5 (.610)	11.4 (.449)	2.0 (.079)							o	o	50	
	5/16	8	FG60-8		8.4 (.331)	22.0 (.866)	44.0(1.732)	17.6 (.693)													
	3/8	10	FG60-10		10.5 (.413)	22.0 (.866)	44.0(1.732)	17.6 (.693)													
	1/2	12	FG60-12		13.0 (.512)	22.0 (.866)	44.0(1.732)	17.6 (.693)													
2/0 (60.57 to 76.28)	5/16	8	FG70-8		8.4 (.331)	23.8 (.937)	47.0(1.850)	17.5 (.689)	17.5 (.689)	13.3 (.524)	2.0 (.079)							o	25		
	3/8	10	FG70-10		10.5 (.413)	23.8 (.937)	47.0(1.850)	17.5 (.689)													
	1/2	12	FG70-12		13.0 (.512)	23.8 (.937)	47.0(1.850)	17.5 (.689)													
3/0 (76.28 to 96.3)	1/4	6	FG80-6		6.4 (.252)	27.0(1.063)	51.0(2.008)	18.1 (.713)	19.5 (.768)	14.5 (.571)	2.3 (.091)							o	25		
	5/16	8	FG80-8		8.4 (.331)	27.0(1.063)	51.0(2.008)	18.1 (.713)													
	3/8	10	FG80-10		10.5 (.413)	27.0(1.063)	51.0(2.008)	18.1 (.713)													
	1/2	12	FG80-12		13.0 (.512)	27.0(1.063)	51.0(2.008)	18.1 (.713)													
4/0 (96.3 to 117.2)	5/16	8	FG100-8		8.4 (.331)	28.6(1.126)	54.0(2.126)	17.7 (.697)	22.3 (.878)	16.4 (.646)	2.6 (.102)							o	25		
	3/8	10	FG100-10		10.5 (.413)	28.6(1.126)	54.0(2.126)	17.7 (.697)													

Note:1) The part numbers indicated in the above table are for products with a brazed seam.
 When ordering products with a nominal size of 1.25 to 5.5 with a butted seam, add the prefix "WS" to the part number (ex. FG2-4 → **WSFG2-4**).
 2) Delivery lead times may vary depending on the product. Contact JST for details.