

# Spezifikation für Freigabe / specification for release

Kunde / customer :  
 Artikelnummer / part number : **7499410221**  
 Bezeichnung : **LAN-Übertrager WE-RJ45LAN 10/100 Base-T PoE+**  
 description : **LAN-Transformer WE-RJ45LAN 10/100 Base-T PoE+**



DATUM / DATE : 2016-01-29

## A Mechanische Abmessungen / dimensions :

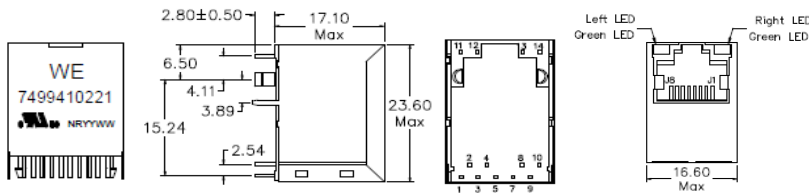

dimensions in mm

## B Lötpad / soldering spec. :

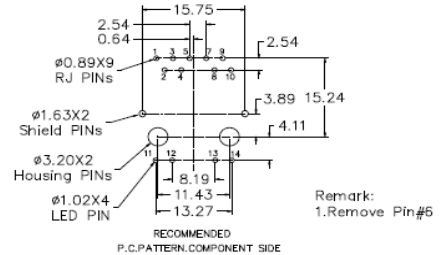

## C Elektrische Eigenschaften / electrical properties :

Eigenschaften / properties	Testbedingungen / test conditions		Wert / value	Einheit / unit	tol.
Induktivität / Inductance	100kHz / 100mV @ 8mA DC-Bias	OCL	350	µH	min.
Übersetzungsverhältnis / Turns ratio	100kHz / 100mV	TR	1 : 1	Tx	±2%
			1 : 1	Rx	
Insertion Loss	1MHz-100MHz	IL	-1,0	dB	max.
Return Loss	1-30MHz @ 100Ω	RL	-16	dB	min.
	30-60MHz @ 100Ω		-14		
	60-80MHz @ 100Ω		-12		
	80-100MHz @ 100Ω		-10		
Common Mode Rejection	1-30MHz	CMRR	-35	dB	min.
	30-60 MHz		-33		
	60-100 MHz		-30		
Crosstalk	1-60MHz	CT	-33	dB	min.
	60-100MHz		-30		

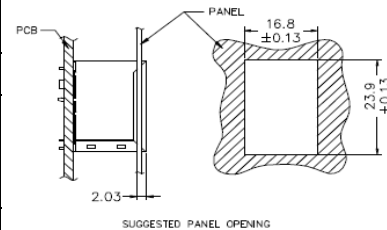

## D Prüfgeräte / test equipment :

HP4395A

## E Testbedingungen / test conditions :

Luftfeuchtigkeit / humidity: 33%  
 Umgebungstemperatur / temperature: +25°C

## F Werkstoffe & Zulassungen / material & approvals :

Basismaterial / base material: Ferrit/ ferrite  
 Draht / wire: xUEW/Y 180  
 Kontaktmaterial/ contact plating: 100% tin w. nickel underplating 30µ"gold plating on contact area  
 Gehäuse / housing: Thermoplastic UL94V-0  
 LED: 1,8-2,8 V/ 20mA  
 Shield: 50µ" nickel over 0.01" cooper alloy

## G Eigenschaften / general specifications :

Betriebstemp. / operating temperature: -40°C - +85°C  
 Hochspannungsprüfung / Hipot test: 1500Vrms 1min.  
 Geeignet für 10/100 Base-T gemäß IEEE 802.3at (600mA über VC1 oder VC2) /  
 Compliant with IEEE 802.3at for 10/100 Base-T applications (600mA when using channel VC1 or VC2)  
 Auto MDIX fähig / Auto MDIX capable

Freigabe erteilt / general release:

Kunde / customer

Datum / date

Unterschrift / signature

Würth Elektronik

Geprüft / checked

Kontrolliert / approved

Mle	Revision 01	2015-01-29
JaB	Revision 00	2015-09-25
Name	Änderung / modification	Datum / date

**Würth Elektronik eiSos GmbH & Co.KG**

D-74638 Waldenburg · Max-Eyth-Straße 1 - 3 · Germany · Telefon (+49) (0) 7942 - 945 - 0 · Telefax (+49) (0) 7942 - 945 - 400

**Spezifikation für Freigabe / specification for release**

Kunde / customer :  
 Artikelnummer / part number : **7499410221**  
 Bezeichnung : **LAN-Übertrager WE-RJ45LAN 10/100 Base-T PoE+**  
 description : **LAN-Transformer WE-RJ45LAN 10/100 Base-T PoE+**



DATUM / DATE : 2016-01-29

**H Schaltbild / Schematics :**

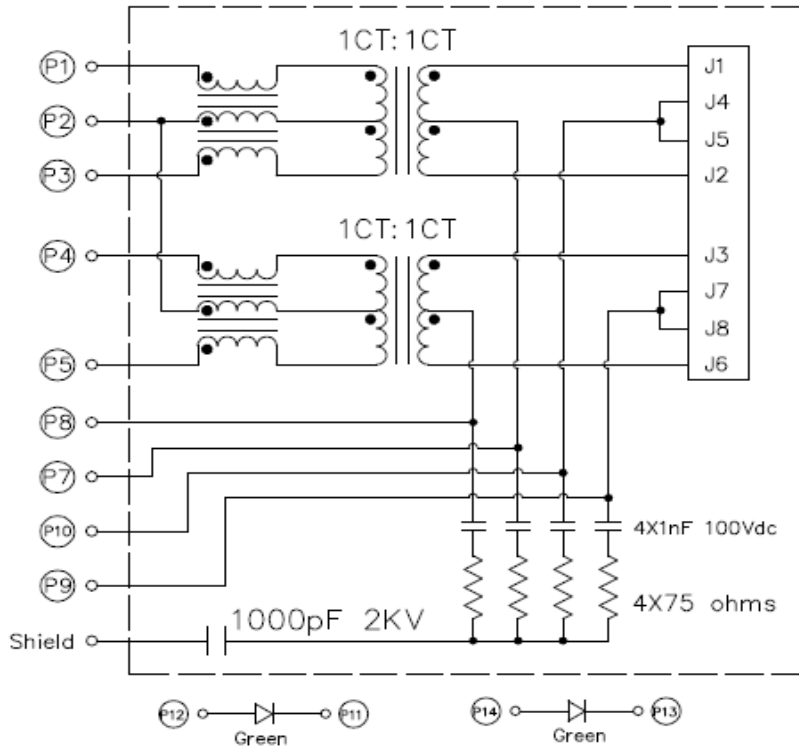

Freigabe erteilt / general release:	<b>Kunde / customer</b>		
.....	.....		
Datum / date	Unterschrift / signature		
	<b>Würth Elektronik</b>		
.....	.....	Mle	Revision 01
Geprüft / checked	Kontrolliert / approved	JaB	Revision 00
		Name	Änderung / modification
			Datum / date

**Würth Elektronik eiSos GmbH & Co.KG**

D-74638 Waldenburg · Max-Eyth-Straße 1 - 3 · Germany · Telefon (+49) (0) 7942 - 945 - 0 · Telefax (+49) (0) 7942 - 945 - 400  
 http://www.we-online.com

# Spezifikation für Freigabe / specification for release

Kunde / customer :  
 Artikelnummer / part number : **7499410221**  
 Bezeichnung : **LAN-Übertrager WE-RJ45LAN 10/100 Base-T PoE+**  
 description : **LAN-Transformer WE-RJ45LAN 10/100 Base-T PoE+**



DATUM / DATE : 2016-01-29

## I Verpackungsspezifikation / package specification :

### PACKAGING(Tube)

#### Tube

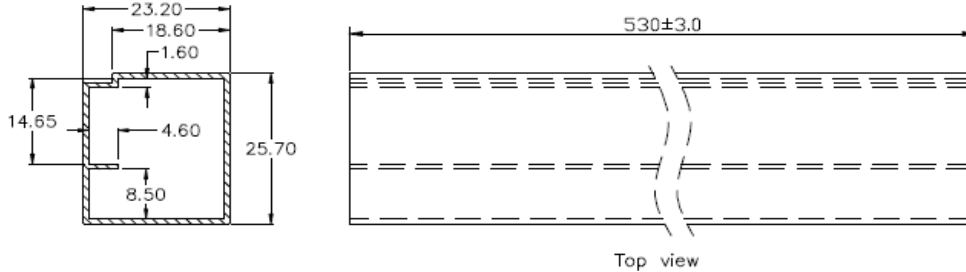

Profile view

#### Carton

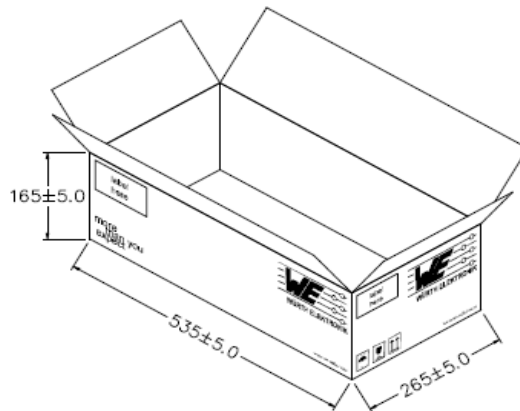

### PACKAGING QUANTITY:

30pcs Finished Goods / Tube  
 60 Tubes (1800pcs Finished Goods) / Carton

Freigabe erteilt / general release:	<b>Kunde / customer</b>			
.....	.....			
Datum / date	Unterschrift / signature			
.....	<b>Würth Elektronik</b>			
.....	.....	Mle	Revision 01	2015-01-29
Geprüft / checked	Kontrolliert / approved	JaB	Revision 00	2015-09-25
.....	.....	Name	Änderung / modification	Datum / date

This electronic component has been designed and developed for usage in general electronic equipment. Before incorporating this component into any equipment where higher safety and reliability is especially required or if there is the possibility of direct damage or injury to human body, for example in the range of aerospace, aviation, nuclear control, submarine, transportation, (automotive control, train control, ship control), transportation signal, disaster prevention, medical, public information network etc. Würth Elektronik eiSos GmbH must be informed before the design-in stage. In addition, sufficient reliability evaluation checks for safety must be performed on every electronic component which is used in electrical circuits that require high safety and reliability functions or performance.

### Würth Elektronik eiSos GmbH & Co.KG

D-74638 Waldenburg · Max-Eyth-Straße 1 - 3 · Germany · Telefon (+49) (0) 7942 - 945 - 0 · Telefax (+49) (0) 7942 - 945 - 400  
<http://www.we-online.com>