

PART NUMBER	REVISION	DESCRIPTION	FEED TYPE
2150074-1	B	FINE CRIMP HEIGHT ADJUST	MECHANICAL
2150074-2	C	FINE CRIMP HEIGHT ADJUST	PNEUMATIC
7-2150074-1	B	MECHANICAL AND CRIMP TOOLING KIT	MECHANICAL
7-2150074-2	C	PNEUMATIC AND CRIMP TOOLING KIT	PNEUMATIC
7-2150074-7	A	CRIMP TOOLING KIT	-

ATLANTIC VERSION TERMINATOR INTERFACE ADAPTER

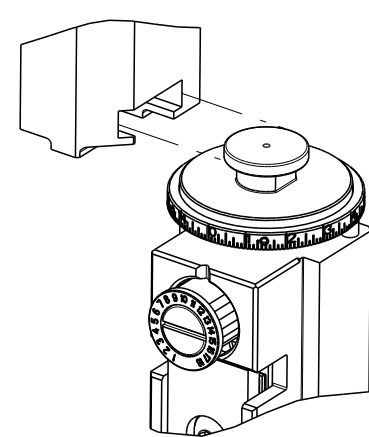

APPLICATOR DATA		
CRIMP	SIZE	TYPE
WIRE	2.29 mm [.090]	F
INSUL	3.56 mm [.140]	F
APPL INSTRUCTIONS 408-35043		

TERMINAL DATA: TE TERMINAL TE CRIMP SPECIFICATION			
TERMINAL NAME: RING			
WIRE STRIP LENGTH	INSULATION DIAMETER RANGE		
4.39-5.16 mm [.173-.203 IN]	Ø2.03-2.79 mm [.080-.110 IN]		
TERMINAL APPLICATION SPECIFICATION	114-2084		
TERMINALS APPLIED			
TE TERMINAL	TE TERMINAL	TE TERMINAL	TE TERMINAL
42037	42037-1	42037-2	42037-8
42037-9	42036-1	42036-2	63797-1
150539	150541	150605-1	1742780-1

TERMINAL DATA: TE TERMINAL TE CRIMP SPECIFICATION			
TERMINAL NAME: RING			
WIRE STRIP LENGTH	INSULATION DIAMETER RANGE		
4.39-5.16 mm [.173-.203 IN]	Ø1.52-2.79 mm [.060-.110 IN]		
TERMINAL APPLICATION SPECIFICATION	114-2084		
TERMINALS APPLIED			
TE TERMINAL	TE TERMINAL	TE TERMINAL	TE TERMINAL
170225-1	170225-2	1-170225-2	

WIRE SIZE	CRIMP HEIGHT mm [INCH]	CRIMP HEIGHT REFERENCE SETTING
18 AWG	1.65+/-0.05 [.065+/-0.002]	5.5
2 x 22 AWG	1.57+/-0.05 [.062+/-0.002]	6.3
20 AWG	1.55+/-0.05 [.061+/-0.002]	6.6
2 x 0.22mm2	1.52+/-0.05 [.060+/-0.002]	6.9
22 AWG	1.50+/-0.05 [.059+/-0.002]	7.1

***WARNING**
ON INSTALLATION, SET WIRE DISC TO CRIMP HEIGHT REFERENCE SETTING FOR LARGEST WIRE SIZE. CRIMP HEIGHT REFERENCE SETTINGS GREATER THAN THE VALUE SHOWN MAY CAUSE DAMAGE TO THE CRIMP TOOLING. REFER TO THE INSTRUCTION SHEET FOR PROPER SETUP AND ADJUSTMENTS.

- RECOMMENDED SPARE PARTS
- REFER TO SUPPLIED INSTRUCTION SHEET FOR CLEANING, LUBRICATION AND STORAGE OF APPLICATOR.
- APPLY PART NUMBER 2-23419-6 LOCTITE TO THREADS OF ITEM 242.
- CRIMP HEIGHT REFERENCE SETTING WAS THE SETTING USED WHEN THE APPLICATOR WAS QUALIFIED AT THE FACTORY. ADJUSTMENT MAY BE NECESSARY WHEN RUNNING APPLICATOR IN THE FIELD.
- UNLESS SPECIFIED OTHERWISE TORQUE VALUES SHALL BE USED PER DOCUMENT, 101-35000.
- THIS CRIMP PARAMETER IS PROVIDED TO MEET A CUSTOM AND UNIQUE CUSTOMER REQUIREMENT. IT HAS BEEN EVALUATED AND IS CONDITIONALLY SPECIFIED BY TE CONNECTIVITY. THIS CUSTOMIZED CRIMP PARAMETER IS NOT LISTED AS AN APPROVED APPLICATION WITHIN A TE CONNECTIVITY APPLICATION SPECIFICATION. **TE CONNECTIVITY EXPRESSLY DISCLAIMS ANY AND ALL WARRANTIES THAT THE PRODUCT WILL PERFORM SIMILARLY TO VALIDATED AND APPROVED APPLICATIONS, AS STATED WITHIN TE CONNECTIVITY APPLICATION SPECIFICATIONS, INCLUDING BUT NOT LIMITED TO IMPLIED WARRANTIES OF MERCHANTABILITY OR FITNESS FOR PARTICULAR PURPOSE.** AS SUCH, IT IS HIGHLY RECOMMENDED THAT THE CUSTOMER PERFORM FURTHER DETAILED EVALUATION TO ASSESS PRODUCT PERFORMANCE IN THE SPECIFIC APPLICATION.

LOC	DIST	REVISIONS					
A	66	P	LTN	DESCRIPTION	DATE	DWN	APVD
		A2		ECR-17-013521	14SEP2017	JAH	JDG
		B		ECR-18-015548	30SEP2018	TB	TE
		C		ECR-20-014688	15OCT2020	TB	RK
		C1		ECR-21-113205	08SEP2021	JWC	TE

-	1	-	1	-	2119641-1	FEED CAM, AIR FEED	248	
-	1	1	1	1	2119082-9	CAM, SNAIL, INSULATION ADJUSTMENT	244	
-	1	1	1	1	2079764-1	WASHER, WAVE SPRING, CREST-TO-CREST	243	
-	1	1	1	1	2119083-1	RETAINER, INSULATION DIAL	242	
-	-	1	-	1	2119580-1	MECHANICAL FEED ASSEMBLY	239	
-	1	-	1	-	2844940-3	AIR FEED MODULE	238	
-	1	1	1	1	1-18028-0	WASHER, FLAT, REG M8	192	
-	REF	REF	REF	REF	994970-2	COUNTER, MAGNETIC	164	
-	1	1	1	1	455888-4	SPACER, CRIMPER	82	
-	1	1	1	1	1803607-4	DOCUMENTATION PACKAGE	71	
-	2	2	2	2	2-18032-2	SCR, SET, FLT PNT, M3 X 10.0	70	
-	1	1	1	1	2119740-1	TAG, IDENTIFICATION	67	
-	2	2	2	2	2168078-1	SCREW, DRIVE, RH, RoHS, 2 x .188	66	
-	1	1	1	1	2168083-2	SCR, SKT HD CAP, RoHS, M4 X 8.0	60	
-	1	1	1	1	5-18022-5	SCR, HEX HD CAP, M4 X 6.0	59	
-	-	1	-	1	2063961-1	FEED FINGER	58	
-	4	4	4	4	2168400-4	SHCS, LOW HEAD, RoHS, M4 X 8	57	
-	2	2	2	2	2168083-2	SCR, SKT HD CAP, RoHS, M4 X 8.0	56	
-	2	2	2	2	5018030-1	NUT, HEX, REG, RoHS, M3	54	
-	2	2	2	2	986965-8	NUT, LOCK, HEX, TORQUE (M4)	53	
-	1	-	1	-	2063961-9	FEED FINGER	51	
-	1	2	1	2	18023-9	SCR, SKT HD CAP M4 X 6.0	49	
-	-	1	-	1	2119652-1	FEED CAM, PRE FEED	48	
-	-	1	-	1	2119653-1	FEED CAM, POST FEED	47	
-	1	1	1	1	2119655-5	APPLICATOR BASIC ASSEMBLY, EF	46	
-	1	1	1	1	1803517-1	RAM ASSEMBLY, EF ATLANTIC	44	
-	1	1	1	1	1803602-1	SCR, BHSC, RoHS (M8 X 25)	41	
-	8	8	8	8	1-18028-2	WASHER, FLAT, REG M4	33	
-	2	2	2	2	2168083-8	SCR, SKT HD CAP, RoHS, M4 X 16	31	
-	2	2	2	2	2168083-2	SCR, SKT HD CAP, RoHS, M4 X 8.0	29	
-	1	1	1	1	240639-1	STRIPPER (MACHINING)	27	
-	2	2	2	2	1-2168083-5	SCR, SKT HD CAP, RoHS, M4 X 30	25	
-	1	1	1	1	1752371-5	PLATE, STRIP GUIDE	24	
-	2	2	2	2	2-22281-3	SPRING, COMPRESSION	22	
-	1	1	1	1	1803292-4	DRAG	20	
-	1	1	1	1	1901696-9	STRIP GUIDE, REAR	19	
-	1	1	1	1	1901695-9	STRIP GUIDE, FRONT	18	
-	4	4	4	4	1-2079383-1	SCR, BHSC, RoHS (M6 X 12)	17	
-	1	1	1	1	240644-9	PLATE, REAR SHEAR	11	
-	-	-	-	-	-	-	10	
-	1	1	1	1	5-690482-7	PLATE, FRONT SHEAR	9	
-	1	2	2	1	1	2-1333217-6	ANVIL, EF .090	8
-	1	1	1	1	2217206-4	BLADE, SLUG	7	
-	-	-	-	-	-	-	6	
-	1	1	1	1	2-240641-4	SPACER	5	
-	1	1	1	1	238011-2	BLOCK, CRIMPER SPACER	4	
-	1	2	2	1	1	1803017-9	CRIMPER, INSULATION F	3
-	1	1	1	1	455888-7	SPACER, CRIMPER	2	
-	1	2	2	1	1	1-456406-6	CRIMPER, WIRE PREMIUM	1
-	77	72	71	2	-1	PART NO	DESCRIPTION	ITEM NO

ATLANTIC VERSION
Shown on sheets 1 of 4 & 2 of 4
(Pacific version shown on sheets 3 of 4 & 4 of 4)

DIMENSIONS:		TOLERANCES UNLESS OTHERWISE SPECIFIED:		DWN L. GROSS 16OCT2013		TE Connectivity Harrisburg, PA 17105-3608	
mm		0 PLC ±		CHK T. ELBIN 16OCT2013		NAME	
Ø		1 PLC ±		APVD M. CLIFFORD 16OCT2013		Ocean End Feed Applicator	
-		2 PLC ±		PRODUCT SPEC		SIZE	
-		3 PLC ±		APPLICATION SPEC		CAGE CODE	
-		4 PLC ±		-		DRAWING NO	
-		ANGLES		-		RESTRICTED TO	
-		FINISH		-		SCALE	
-		-		WEIGHT		SHEET	
-		-		-		1 OF 4	
-		-		Customer Accessible Production Drawing		REV	
-		-		SCALE 1:1		C1	

LOC	DIST	REV	DESCRIPTION	DATE	OWN	APVD
A	66		SEE SHEET 1			

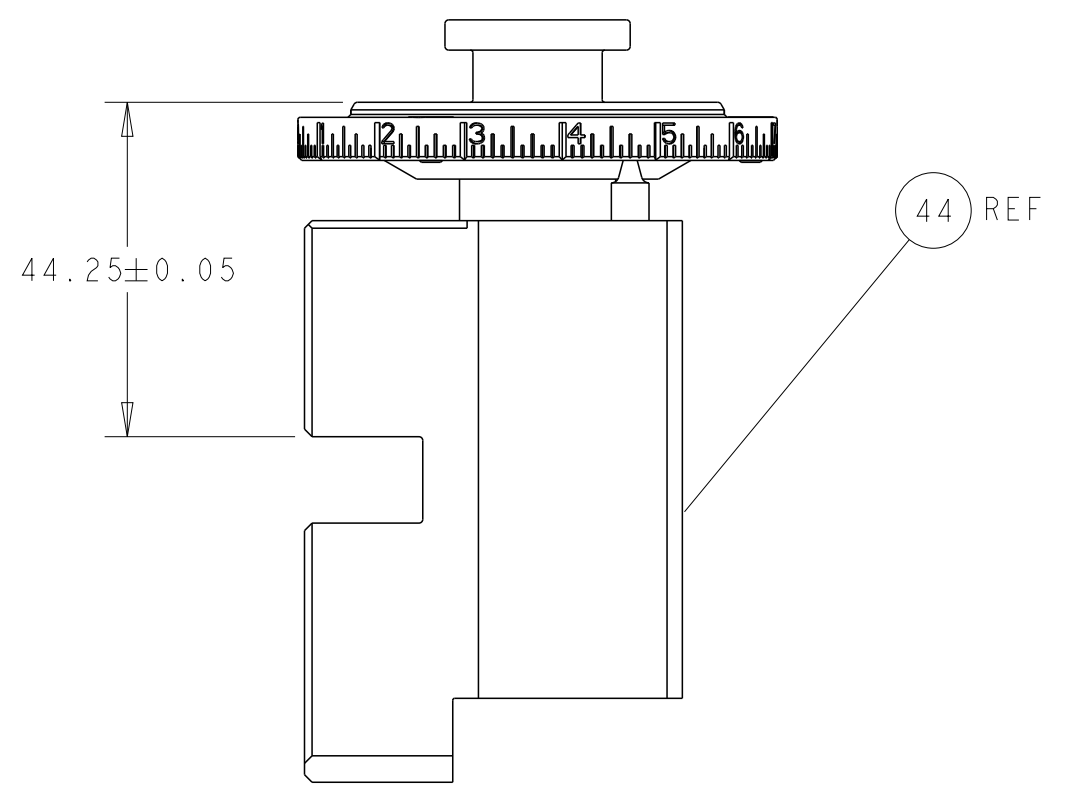

RAM SET-UP

FEED TYPE
MECHANICAL

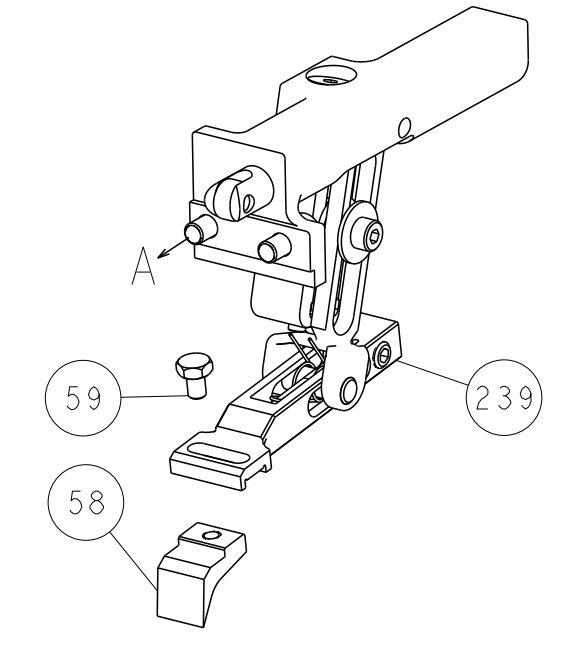

PNEUMATIC

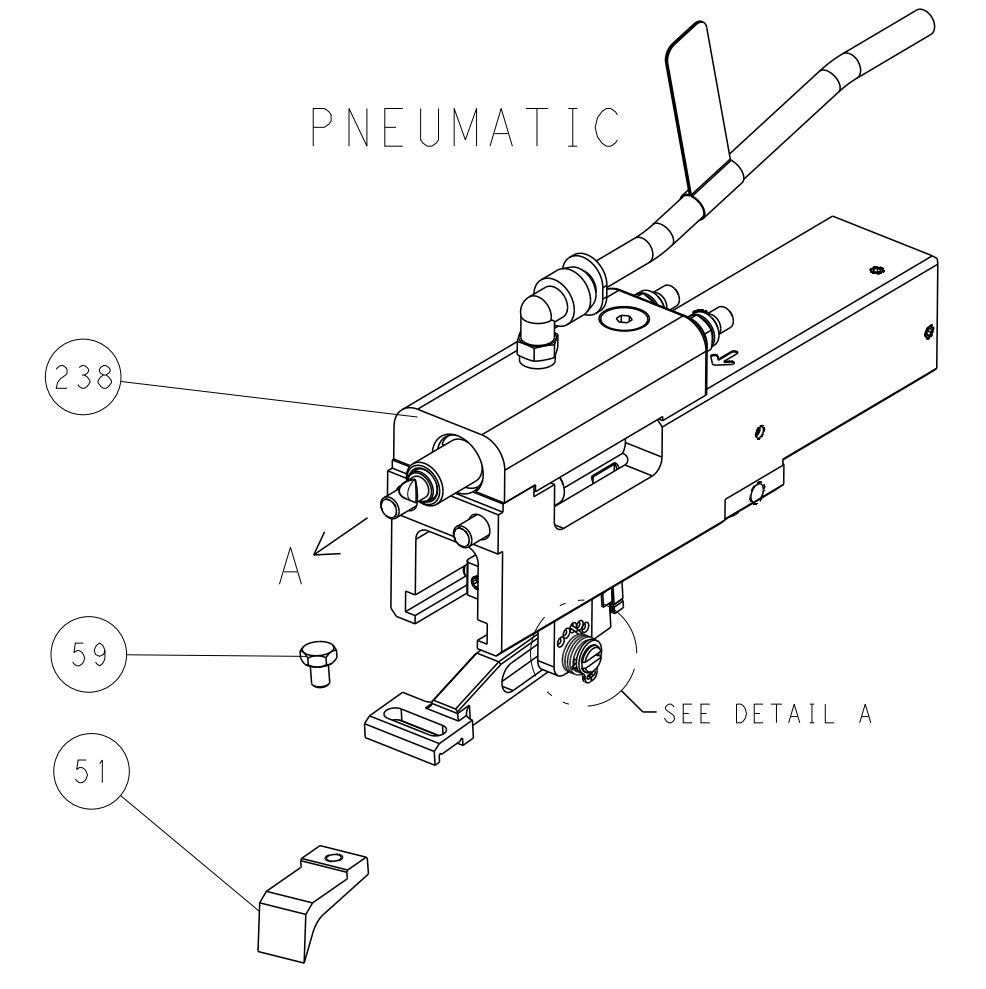

FEED SPRING
SETTING POSITION

DETAIL A

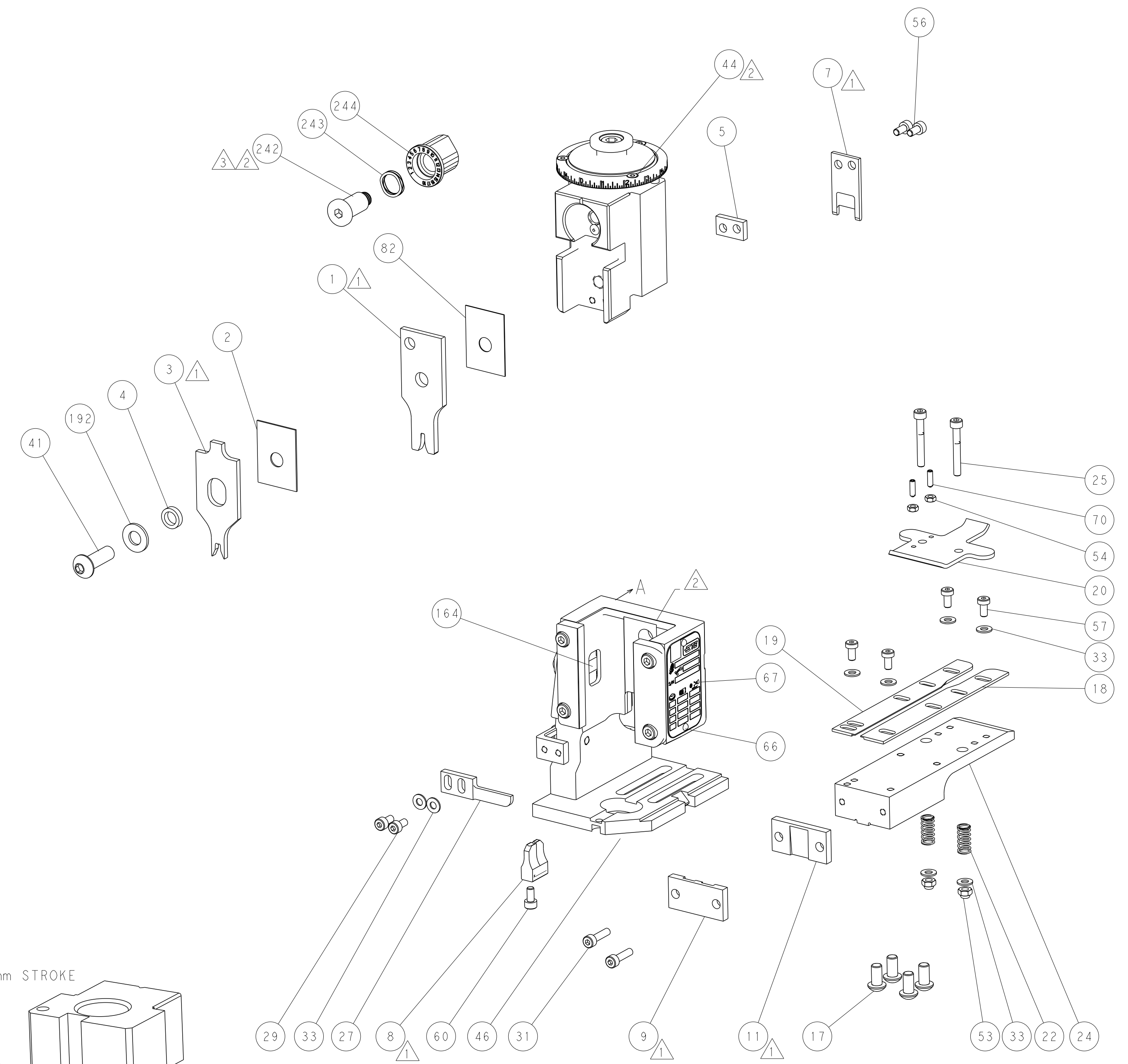

CAM POSITIONS

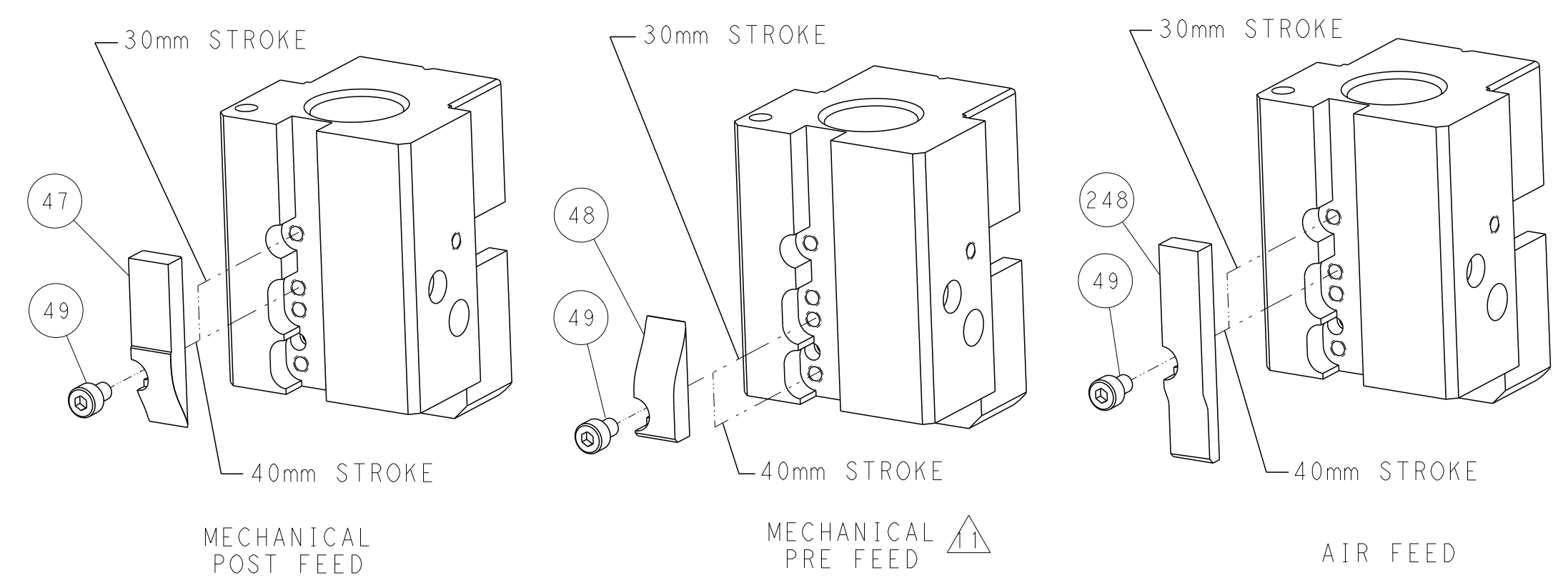

ATLANTIC VERSION
 Shown on sheets 1 of 4 & 2 of 4
 (Pacific version shown on sheets 3 of 4 & 4 of 4)

<small>THIS DRAWING IS UNPUBLISHED. RELEASED FOR PUBLICATION. ALL RIGHTS RESERVED. © 2013 BY TYCO ELECTRONICS CORPORATION.</small>		DWN: L.GROSS 16OCT2013 CHK: T.ELBIN 16OCT2013 APVD: M.CLIFFORD 16OCT2013	TE Connectivity Harrisburg, PA 17105-3608
DIMENSIONS: mm TOLERANCES UNLESS OTHERWISE SPECIFIED: 0 PLC ± 1 PLC ± 2 PLC ± 3 PLC ± 4 PLC ± ANGLES ± FINISH		NAME: Ocean End Feed Applicator SIZE: A1 CAGE CODE: 00779 DRAWING NO: 2150074	RESTRICTED TO: - SCALE: 1:1 SHEET: 2 of 4 REV: C1
MATERIAL: - FINISH: -		WEIGHT: - Customer Accessible Production Drawing	SHEETS 3 & 4 ARE NOT REQUIRED FOR ATLANTIC VERSION

PART NUMBER	REVISION	DESCRIPTION	FEED TYPE
2-2150074-1	B	FINE CRIMP HEIGHT ADJUST	MECHANICAL
2-2150074-2	C	FINE CRIMP HEIGHT ADJUST	PNEUMATIC
7-2150074-7	A	CRIMP TOOLING KIT	-

PACIFIC VERSION TERMINATOR
INTERFACE ADAPTER

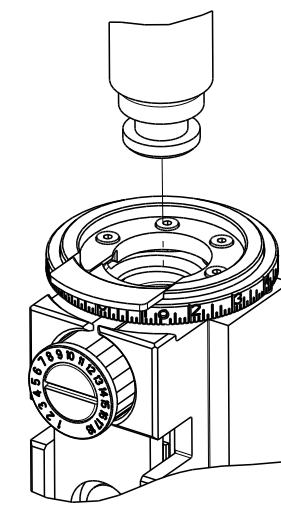

APPLICATOR DATA		
CRIMP	SIZE	TYPE
WIRE	2.29 mm [.090]	F
INSUL	3.56 mm [.140]	F
APPL INSTRUCTIONS 408-35043		

TERMINAL DATA: TE TERMINAL				TE CRIMP SPECIFICATION			
TERMINAL NAME: RING							
WIRE STRIP LENGTH 4.39-5.16 mm [.173-.203 IN]				INSULATION DIAMETER RANGE Ø2.03-2.79 mm [.080-.110 IN]			
TERMINAL APPLICATION SPECIFICATION 114-2084							
TERMINALS APPLIED							
TE TERMINAL	TE TERMINAL	TE TERMINAL	TE TERMINAL	TE TERMINAL	TE TERMINAL	TE TERMINAL	TE TERMINAL
42037	42037-1	42037-2	42037-8	42037-9	42036-1	42036-2	63797-1
150539	150541	150605-1	1742780-1				

TERMINAL DATA: TE TERMINAL				TE CRIMP SPECIFICATION			
TERMINAL NAME: RING							
WIRE STRIP LENGTH 4.39-5.16 mm [.173-.203 IN]				INSULATION DIAMETER RANGE Ø1.52-2.79 mm [.060-.110 IN]			
TERMINAL APPLICATION SPECIFICATION 114-2084							
TERMINALS APPLIED							
TE TERMINAL	TE TERMINAL	TE TERMINAL	TE TERMINAL	TE TERMINAL	TE TERMINAL	TE TERMINAL	TE TERMINAL
170225-1	170225-2	1-170225-2					

WIRE SIZE	CRIMP HEIGHT mm [INCH]	CRIMP HEIGHT REFERENCE SETTING
18 AWG	1.65+/-0.05 [.065+/-0.002]	5.5
2 x 22 AWG	1.57+/-0.05 [.062+/-0.002]	6.3
20 AWG	1.55+/-0.05 [.061+/-0.002]	6.6
2 x 0.22mm2	1.52+/-0.05 [.060+/-0.002]	6.9
22 AWG	1.50+/-0.05 [.059+/-0.002]	7.1

***WARNING**
ON INSTALLATION, SET WIRE DISC TO CRIMP HEIGHT REFERENCE SETTING FOR LARGEST WIRE SIZE. CRIMP HEIGHT REFERENCE SETTINGS GREATER THAN THE VALUE SHOWN MAY CAUSE DAMAGE TO THE CRIMP TOOLING. REFER TO THE INSTRUCTION SHEET FOR PROPER SETUP AND ADJUSTMENTS.

- 1. RECOMMENDED SPARE PARTS
- 2. REFER TO SUPPLIED INSTRUCTION SHEET FOR CLEANING, LUBRICATION AND STORAGE OF APPLICATOR.
- 3. APPLY PART NUMBER 2-23419-6 LOCTITE TO THREADS OF ITEM 242.
- 4. CRIMP HEIGHT REFERENCE SETTING WAS THE SETTING USED WHEN THE APPLICATOR WAS QUALIFIED AT THE FACTORY. ADJUSTMENT MAY BE NECESSARY WHEN RUNNING APPLICATOR IN THE FIELD.
- 5. UNLESS SPECIFIED OTHERWISE TORQUE VALUES SHALL BE USED PER DOCUMENT, 101-35000.
- 6. THIS CRIMP PARAMETER IS PROVIDED TO MEET A CUSTOM AND UNIQUE CUSTOMER REQUIREMENT. IT HAS BEEN EVALUATED AND IS CONDITIONALLY SPECIFIED BY TE CONNECTIVITY. THIS CUSTOMIZED CRIMP PARAMETER IS NOT LISTED AS AN APPROVED APPLICATION WITHIN A TE CONNECTIVITY APPLICATION SPECIFICATION. **TE CONNECTIVITY EXPRESSLY DISCLAIMS ANY AND ALL WARRANTIES THAT THE PRODUCT WILL PERFORM SIMILARLY TO VALIDATED AND APPROVED APPLICATIONS, AS STATED WITHIN TE CONNECTIVITY APPLICATION SPECIFICATIONS, INCLUDING BUT NOT LIMITED TO IMPLIED WARRANTIES OF MERCHANTABILITY OR FITNESS FOR PARTICULAR PURPOSE.** AS SUCH, IT IS HIGHLY RECOMMENDED THAT THE CUSTOMER PERFORM FURTHER DETAILED EVALUATION TO ASSESS PRODUCT PERFORMANCE IN THE SPECIFIC APPLICATION.

LOC	DIST	REV	DATE	BY	APPV
A	66	-	-	-	-

REV	DATE	BY	APPV	DESCRIPTION	ITEM NO	
-	1	1		2119082-9	CAM, SNAIL, INSULATION ADJUSTMENT	244
-	1	1		2079764-1	WASHER, WAVE SPRING, CREST-TO-CREST	243
-	1	1		2119083-1	RETAINER, INSULATION DIAL	242
-	-	1		2119580-1	MECHANICAL FEED ASSEMBLY	239
-	1	-		2844940-3	AIR FEED MODULE	238
-	1	1		1-18028-0	WASHER, FLAT, REG M8	192
-	4	4		2079383-9	SCR, BHSC, RoHS (M6 X 20)	186
-	REF	REF		994970-2	COUNTER, MAGNETIC	164
-	1	-		2119641-2	FEED CAM, AIR FEED	152
-	1	1		2168083-8	SCR, SKT HD CAP, RoHS, M4 X 16	144
-	-	1		2119653-2	FEED CAM, POST FEED	142
-	1	1		2119655-6	APPLICATOR BASIC ASSEMBLY, EF	141
-	1	1		1803518-1	RAM ASSEMBLY, EF PACIFIC	140
-	1	1		455888-4	SPACER, CRIMPER	82
-	1	1		1803607-4	DOCUMENTATION PACKAGE	71
-	2	2		2-18032-2	SCR, SET, FLT PNT, M3 X 10.0	70
-	1	1		2119740-1	TAG, IDENTIFICATION	67
-	2	2		2168078-1	SCREW, DRIVE, RH, RoHS, 2 x .188	66
-	1	1		5-18022-5	SCR, HEX HD CAP, M4 X 6.0	59
-	-	1		2063961-1	FEED FINGER	58
-	4	4		2168400-4	SHCS, LOW HEAD, RoHS, M4 X 8	57
-	2	2		2168083-2	SCR, SKT HD CAP, RoHS, M4 X 8.0	56
-	2	2		5018030-1	NUT, HEX, REG, RoHS, M3	54
-	2	2		986965-8	NUT, LOCK, HEX, TORQUE (M4)	53
-	1	-		2063961-9	FEED FINGER	51
-	1	2		18023-9	SCR, SKT HD CAP M4 X 6.0	49
-	-	1		2119652-1	FEED CAM, PRE FEED	48
-	1	1		1803602-1	SCR, BHSC, RoHS (M8 X 25)	41
-	8	8		1-18028-2	WASHER, FLAT, REG M4	33
-	2	2		2168083-8	SCR, SKT HD CAP, RoHS, M4 X 16	31
-	2	2		2168083-2	SCR, SKT HD CAP, RoHS, M4 X 8.0	29
-	1	1		240639-1	STRIPPER (MACHINING)	27
-	2	2		1-2168083-5	SCR, SKT HD CAP, RoHS, M4 X 30	25
-	1	1		1752371-5	PLATE, STRIP GUIDE	24
-	2	2		2-22281-3	SPRING, COMPRESSION	22
-	1	1		1803292-4	DRAG	20
-	1	1		1901696-9	STRIP GUIDE, REAR	19
-	1	1		1901695-9	STRIP GUIDE, FRONT	18
-	1	1		240644-9	PLATE, REAR SHEAR	11
-	-	-		-	-	10
-	1	1		5-690482-7	PLATE, FRONT SHEAR	9
-	1	1		2-1333217-6	ANVIL, EF .090	8
-	1	1		2217206-4	BLADE, SLUG	7
-	-	-		-	-	6
-	1	1		2-240641-4	SPACER	5
-	1	1		238011-2	BLOCK, CRIMPER SPACER	4
-	1	1		1803017-9	CRIMPER, INSULATION F	3
-	1	1		455888-7	SPACER, CRIMPER	2
-	1	1		1-456406-6	CRIMPER, WIRE PREMIUM	1
-	77	22	21	PART NO	DESCRIPTION	ITEM NO

PACIFIC VERSION
Shown on sheets 3 of 4 & 4 of 4
(Atlantic version shown on sheets 1 of 4 & 2 of 4)

DIMENSIONS: mm		TOLERANCES UNLESS OTHERWISE SPECIFIED:		DWN: T. ELBIN		CHK: M. CLIFFORD		APV: M. CLIFFORD		NAME: Ocean End Feed Applicator	
0 PLC ±		1 PLC ±		2 PLC ±		3 PLC ±		4 PLC ±		ANGLES ±	
FINISH		MATERIAL		WEIGHT		SCALE		SHEET		REV	
-		-		-		1:1		3 OF 4		C1	

LOC	DIST	REVISIONS					
A	66	P	LTN	DESCRIPTION	DATE	DWN	APVD
		-		SEE SHEET 1			

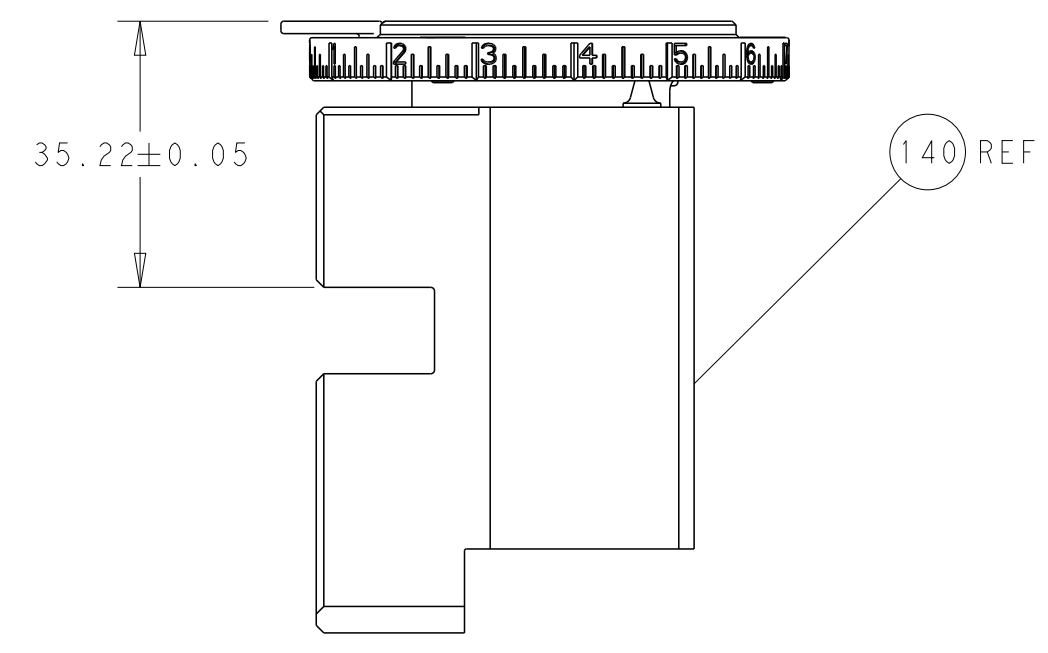

RAM SET-UP

FEED TYPE
MECHANICAL

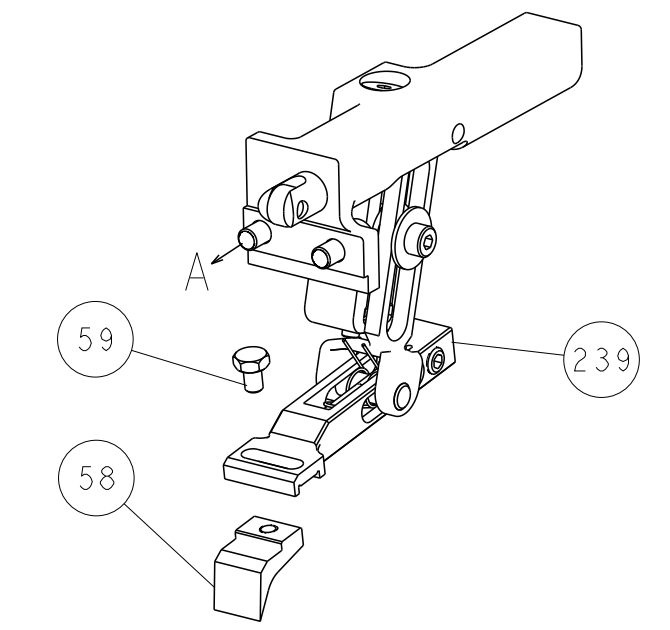

PNEUMATIC

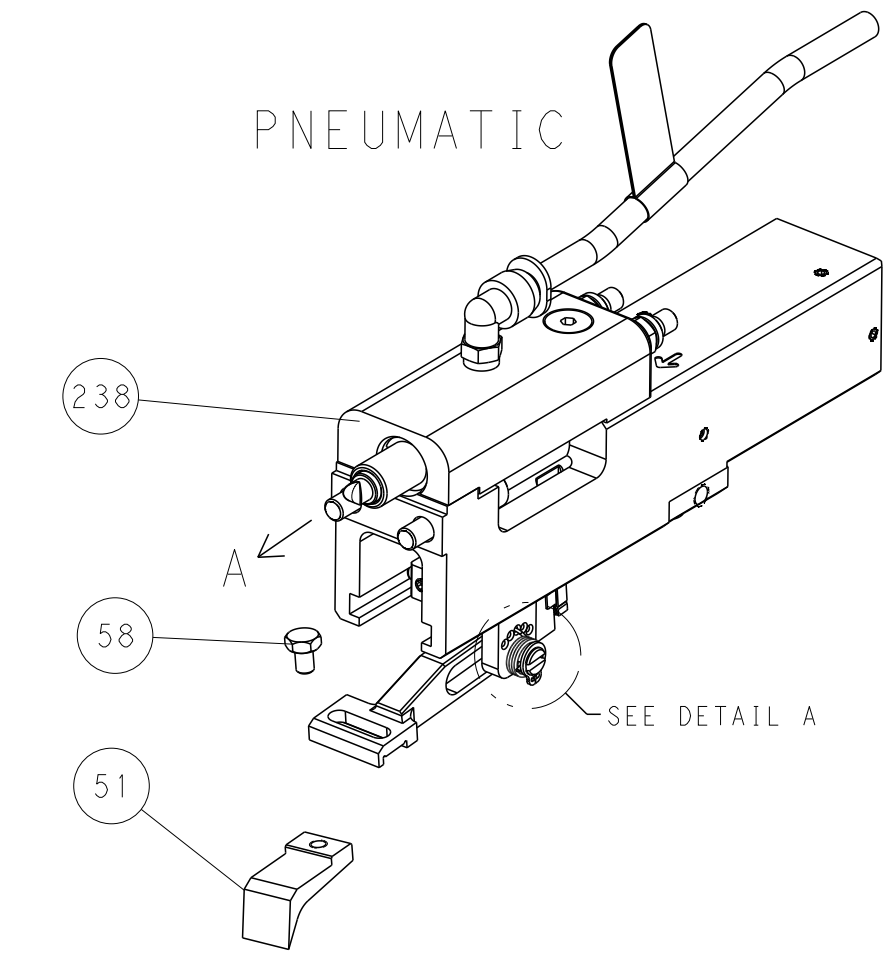

FEED SPRING
SETTING POSITION

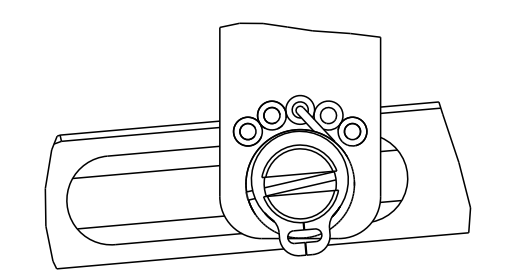

DETAIL A

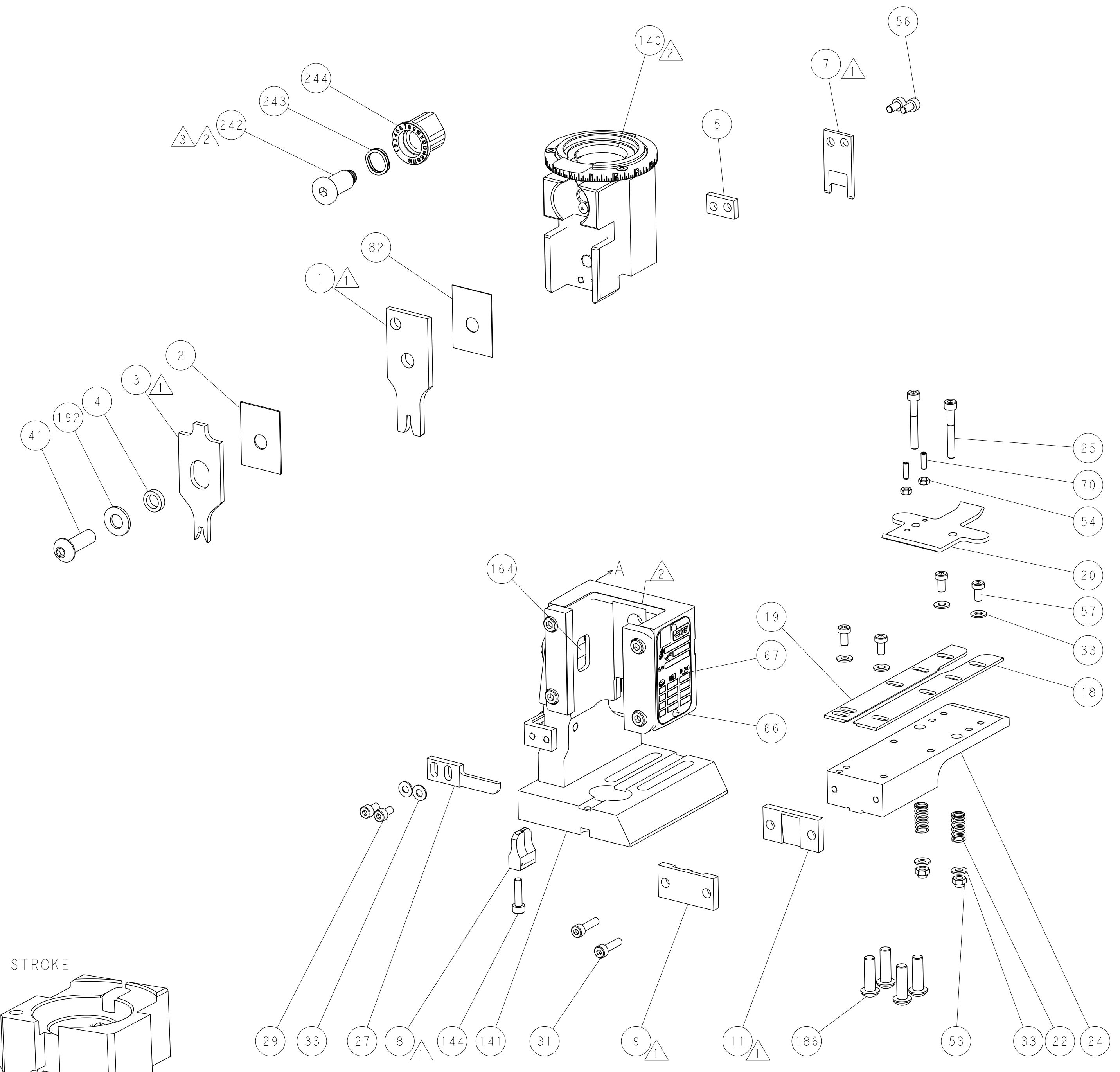

CAM POSITIONS

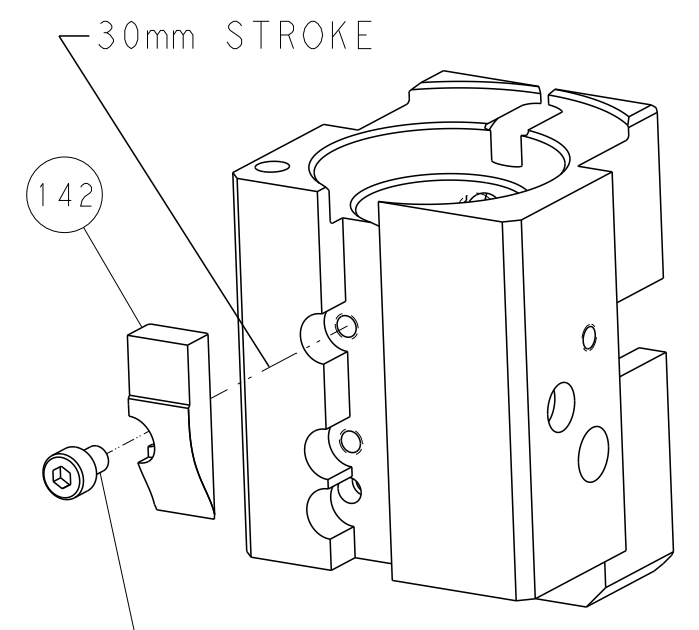

MECHANICAL
POST FEED

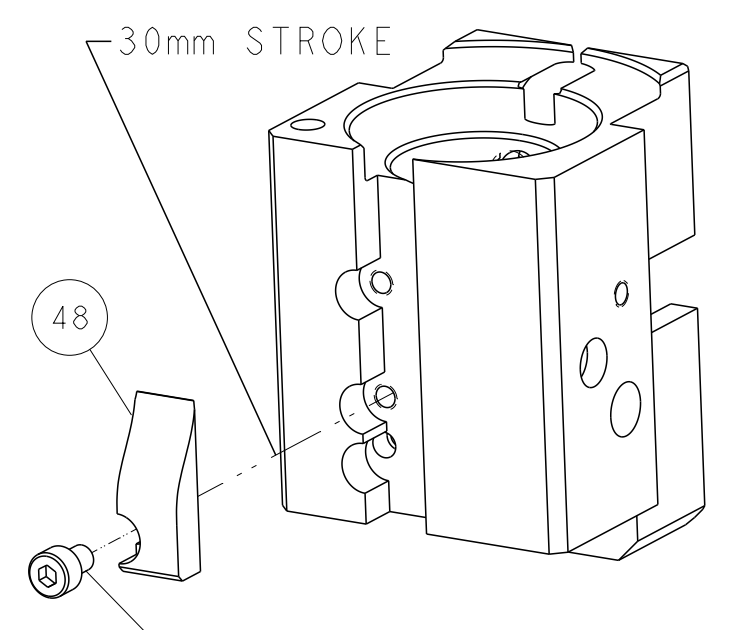

MECHANICAL
PRE FEED

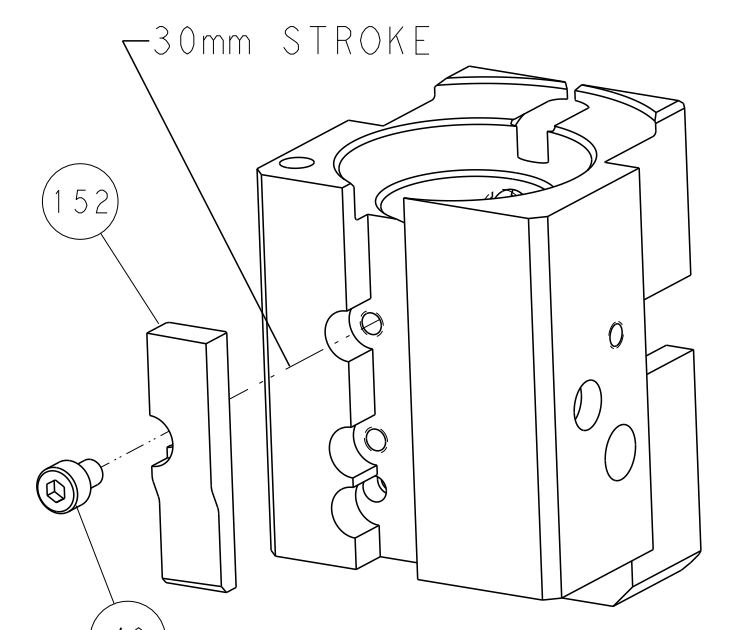

AIR FEED

PACIFIC VERSION
 Shown on sheets 3 of 4 & 4 of 4
 (Atlantic version shown on sheets 1 of 4 & 2 of 4)

<small>THIS DRAWING IS UNPUBLISHED. RELEASED FOR PUBLICATION. ALL RIGHTS RESERVED. © 2013 BY TYCO ELECTRONICS CORPORATION. THIS DRAWING IS THE PROPERTY OF TYCO ELECTRONICS CORPORATION AND IS NOT TO BE REPRODUCED OR TRANSMITTED IN ANY FORM OR BY ANY MEANS, ELECTRONIC OR MECHANICAL, INCLUDING PHOTOCOPYING, RECORDING, OR BY ANY INFORMATION STORAGE AND RETRIEVAL SYSTEM, WITHOUT THE WRITTEN PERMISSION OF TYCO ELECTRONICS CORPORATION.</small>		DWN: L.GROSS 16OCT2013 CHK: T.ELBIN 16OCT2013 APVD: M.CLIFFORD 16OCT2013	TE Connectivity Harrisburg, PA 17105-3608
DIMENSIONS: mm TOLERANCES UNLESS OTHERWISE SPECIFIED: 0 PLC ± 1 PLC ± 2 PLC ± 3 PLC ± 4 PLC ± ANGLES ± MATERIAL: - FINISH: -		NAME: Ocean End Feed Applicator APPLICATION SPEC: - PRODUCT SPEC: - WEIGHT: - SCALE: 1:1	SIZE: A1 CAGE CODE: 00779 DRAWING NO: 2150074 SHEET: 4 OF 4 REV: C1