



ANATECH ELECTRONICS INC
RF & Microwave Filters & Products

500 MHz Band Pass Filter

Part Number: AE500B10400



Electrical Specifications

Center Frequency: 500 MHz
Bandwidth: 60 MHz
Passband: 470-530 MHz (3dB Flatness Max)
Insertion Loss at Fc: 1.0 dB Max
Return Loss: 14 dB Min
Rejection: >50 dB @ 0-370 MHz
 >50 dB @ 630-2000 MHz

Mechanical

Connector Type: BNC (F)
Dimensions: 4.0 x 1.25 x 0.75 Inches

Environmental

Operating Temperature: -30 to +70° C
Storage Temperature: -40 to +85° C

Outline Drawing:

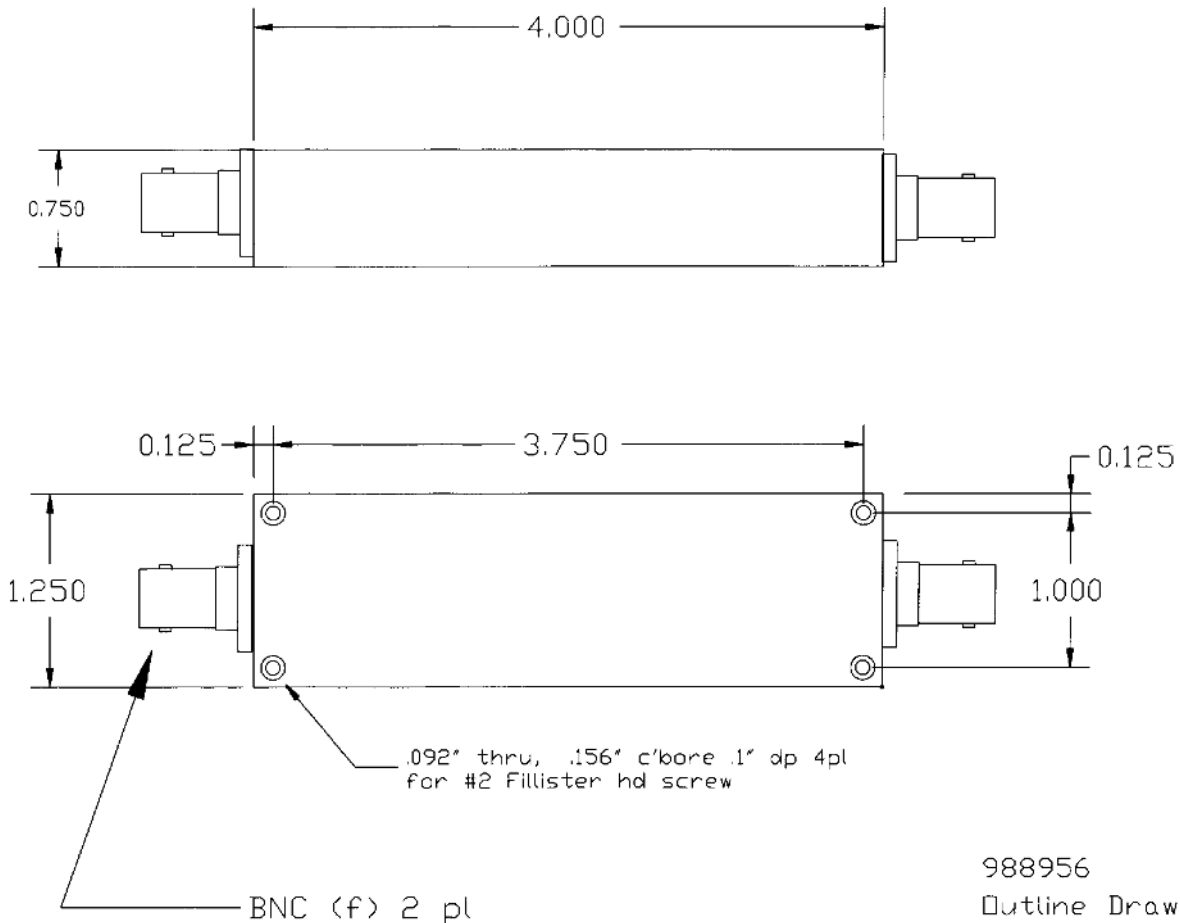

988956
Outline Drawing
(987530)



Response Plot:

A4129.lad

SEP 28, 2009

Attenuation/Return Loss

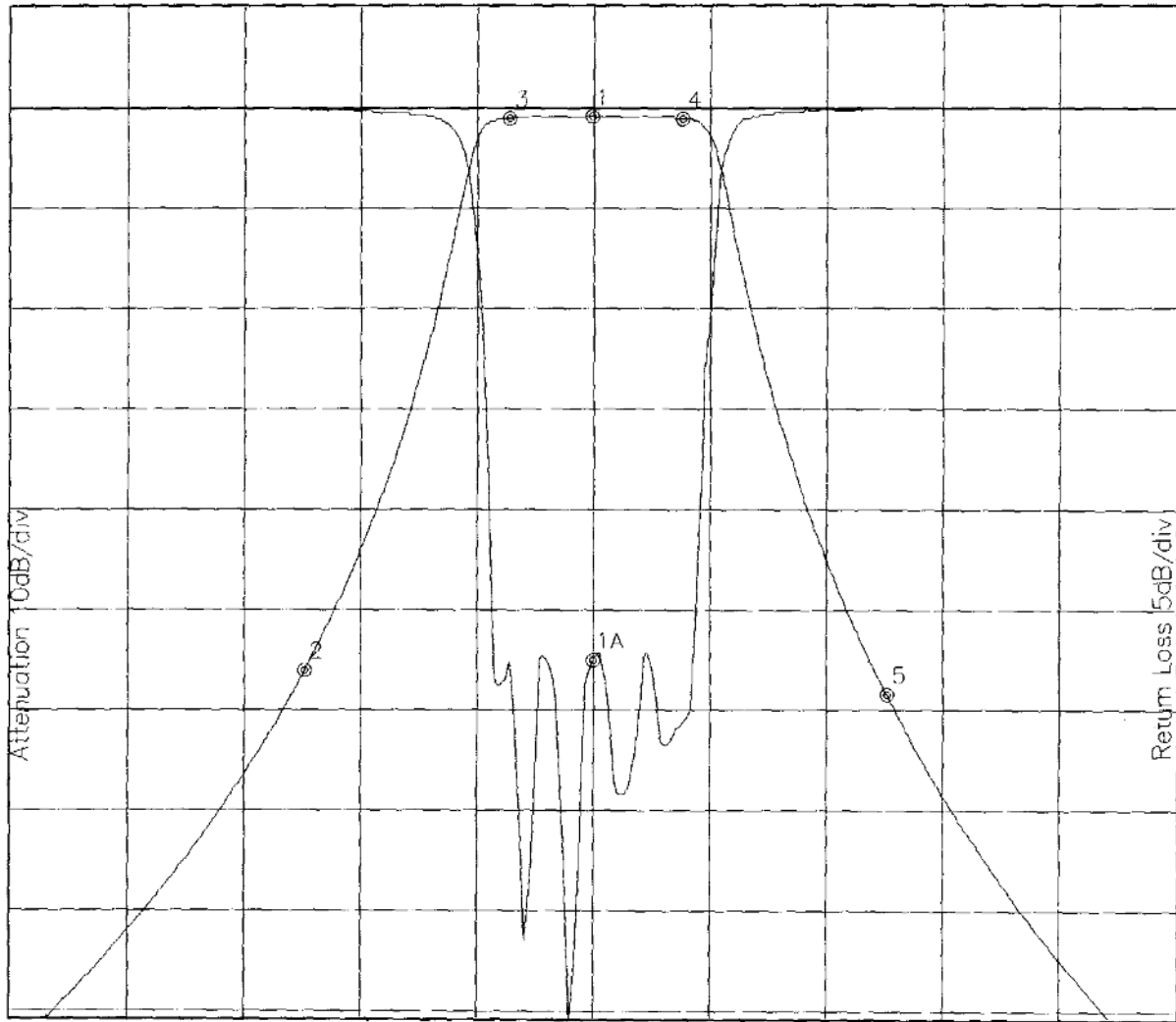

Attenuation Start: 300.0MHz Stop: 700.0MHz

Return Loss Start: 300.0MHz Stop: 700.0MHz

Marker 1 Freq 499.03MHz Atten -0.791dB
 Marker 2 Freq 400.16MHz Atten -56.112dB
 Marker 3 Freq 470.59MHz Atten -1.020dB
 Marker 4 Freq 530.04MHz Atten -1.061dB
 Marker 5 Freq 600.48MHz Atten -58.540dB

Marker 1A Freq 499.67MHz Ret Loss -27.446dB