



12V, Ultra-Low-I_Q, Low-Dropout Linear Regulators with POK

MAX8880/MAX8881

General Description

The MAX8880/MAX8881 are ultra-low supply current, low-dropout linear regulators, capable of delivering up to 200mA. They are designed for battery-powered applications where reverse battery protection and long battery life are critical.

These regulators' low 3.5 μ A supply current extends battery life in applications with long standby periods. Unlike PNP-based designs, a 2 Ω PMOS device maintains ultra-low supply current throughout the entire operating range and in dropout. The parts are internally protected from output short circuits, reverse battery connection, and thermal overload. An internal power-OK (POK) comparator indicates when the output is out of regulation.

The MAX8880 output is adjustable from 1.25V to 5V using an external resistor-divider. The MAX8881 provides only factory-preset output voltages of 1.8V, 2.5V, 3.3V, or 5V (see *Ordering Information*). The devices are available in 6-pin SOT23 and 6-pin TDFN packages.

Applications

Smoke Detectors	PDA's
Battery-Powered Alarms	Handy Terminals
Remote Transmitters	CMOS Backup Power
Smart Battery Packs	Real-Time Clocks

Pin Configurations

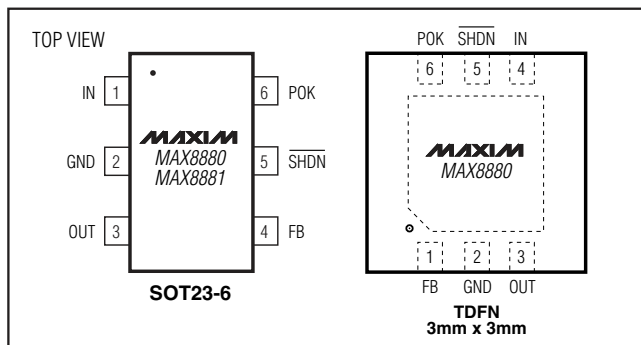

Typical Operating Circuit

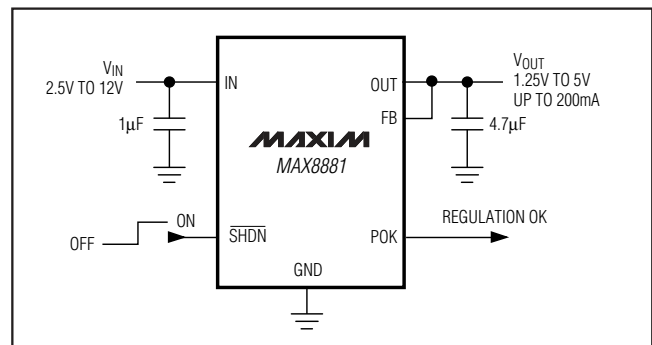

Ordering Information

PART	OUTPUT	TEMP RANGE	PIN-PACKAGE	TOP MARK
MAX8880EUT-T	Adjustable	-40°C to +85°C	6 SOT23-6	AAHR
MAX8880ETT-T	Adjustable	-40°C to +85°C	6 TDFN	AGS
MAX8881EUT18-T	1.8V	-40°C to +85°C	6 SOT23-6	AAHS
MAX8881EUT25-T	2.5V	-40°C to +85°C	6 SOT23-6	AAHT
MAX8881EUT33-T	3.3V	-40°C to +85°C	6 SOT23-6	AAHU
MAX8881EUT50-T	5.0V	-40°C to +85°C	6 SOT23-6	AAHV



12V, Ultra-Low-I_Q, Low-Dropout Linear Regulators with POK

ABSOLUTE MAXIMUM RATINGS

IN to GND	-14V to +14V
SHDN to GND	-0.3V to (V _{IN} + 0.3V), -0.3V to +0.3V when V _{IN} < 0V
OUT, FB to GND	-0.3V to +6V when V _{IN} > 5.7V, -0.3V to (V _{IN} + 0.3V) when 0V ≤ V _{IN} ≤ 5.7V, -0.3V to +0.3V when V _{IN} < 0V
POK to GND	-0.3V to +14V

OUT Continuous Current.....	200mA
OUT Short Circuit.....	Indefinite
Continuous Power Dissipation (T _A = +70°C)	
6-Pin SOT23 (derate 8.7mW/°C above +70°C).....	696mW
6-Pin TDFN (derate 24.4mW/°C above +70°C)	1951mW
Operating Temperature Range	-40°C to +85°C
Junction Temperature	+150°C
Storage Temperature.....	-65°C to +165°C
Lead Temperature (soldering, 10s)	+300°C

Stresses beyond those listed under "Absolute Maximum Ratings" may cause permanent damage to the device. These are stress ratings only, and functional operation of the device at these or any other conditions beyond those indicated in the operational sections of the specifications is not implied. Exposure to absolute maximum rating conditions for extended periods may affect device reliability.

ELECTRICAL CHARACTERISTICS

(V_{IN} = V_{OUT} + 1V, SHDN = IN, C_{OUT} = 4.7μF, T_A = -40°C to +85°C, unless otherwise noted. Typical values are at T_A = +25°C.) (Note 1)

PARAMETER	SYMBOL	CONDITIONS	MIN	TYP	MAX	UNITS	
Input Voltage Range	V _{IN}		2.5		12	V	
Supply Current	I _{IN}	V _{IN} = 12V		3.5	10	μA	
Shutdown Supply Current	I _{IN(SHDN)}	V _{SHDN} = 0, V _{IN} = 12V, V _{OUT} = 0, T _A = +25°C		1.5	3	μA	
Input Undervoltage Lockout	V _{UVLO}			2.1	2.4	V	
FB Voltage, Adjustable Mode	V _{FB}	MAX8880, I _{OUT} = 20mA	T _A = +25°C	1.238	1.257	1.276	V
			T _A = 0°C to +85°C	1.232		1.282	
			T _A = -40°C to +85°C	1.219		1.295	
OUT Voltage Accuracy (Note 2)		MAX8881, I _{OUT} = 20mA	T _A = +25°C	-1.5		1.5	%
			T _A = 0°C to +85°C	-2		2	
			T _A = -40°C to +85°C	-3		3	
OUT Voltage Range	V _{OUT}	MAX8880	1.25		5.5	V	
OUT Line Regulation		V _{IN} = V _{OUT} + 1V to 12V		0.01	0.05	%/V	
OUT Load Regulation (Note 3)		I _{OUT} = 10μA to 100mA		0.006	0.015	%/mA	
Current Limit (Note 3)	I _{OUT}		200	400		mA	
Dropout Voltage (Notes 3, 4)	ΔV _{DO}	I _{OUT} = 50mA		100	200	mV	
IN Reverse Leakage Current	I _{IN(REV)}	V _{IN} = -12V, V _{SHDN} = 0			1	mA	
Foldback Current Limit	I _{OUT(SC)}	V _{IN} = 5V, V _{OUT} = 0		250		mA	
SHDN Input Threshold	V _{IH}	V _{IN} = 2.5V to 12V	2			V	
	V _{IL}			0.5			
SHDN Input Bias Current		V _{SHDN} = 0 to 12V, T _A = +25°C	-100		100	nA	
FB Input Bias Current	I _{FB}	FB = 1.25V, T _A = +25°C, MAX8880 only	0	2	20	nA	
POK Trip Threshold		Falling	T _A = +25°C	87.5	90.5	93.5	% of V _{OUT}
			T _A = -40°C to +85°C	86		95	
		Hysteresis		1.5			
POK Off-Current	I _{POK}	V _{POK} = 12V, T _A = +25°C			100	nA	
POK Low Voltage	V _{POK}	I _{POK} = 1mA		50	200	mV	

12V, Ultra-Low-I_Q, Low-Dropout Linear Regulators with POK

MAX8880/MAX8881

ELECTRICAL CHARACTERISTICS (continued)

($V_{IN} = V_{OUT} + 1V$, $\overline{SHDN} = IN$, $C_{OUT} = 4.7\mu F$, $T_A = -40^\circ C$ to $+85^\circ C$, unless otherwise noted. Typical values are at $T_A = +25^\circ C$.) (Note 1)

PARAMETER	SYMBOL	CONDITIONS	MIN	TYP	MAX	UNITS
Thermal Shutdown Threshold	T_{TSD}	(Hysteresis = 15°C)		160		°C
OUT Noise	$V_{OUT(Noise)}$	$f = 10\text{Hz to }100\text{kHz}$, $I_{OUT} = 1\text{mA}$		300		μV_{RMS}

Note 1: All devices are 100% production tested at $T_A = +25^\circ C$. All temperature limits are guaranteed by design.

Note 2: Output accuracy with respect to nominal preset voltages. $FB = OUT$.

Note 3: This specification is valid for $V_{IN} > 3V$.

Note 4: The dropout voltage is defined as $V_{IN} - V_{OUT}$, when V_{OUT} is 100mV below the value of V_{OUT} for $V_{IN} = V_{OUT} + 1V$.

Typical Operating Characteristics

($V_{IN} = 5V$, $V_{OUT} = 3.3V$, $I_{OUT} = 30\text{mA}$, $C_{OUT} = 4.7\mu F$, $T_A = +25^\circ C$, unless otherwise noted. See Figure 1.)

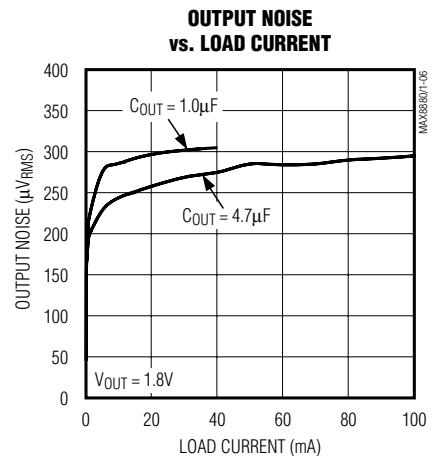
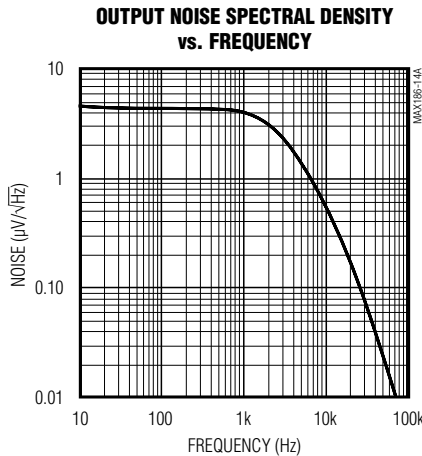
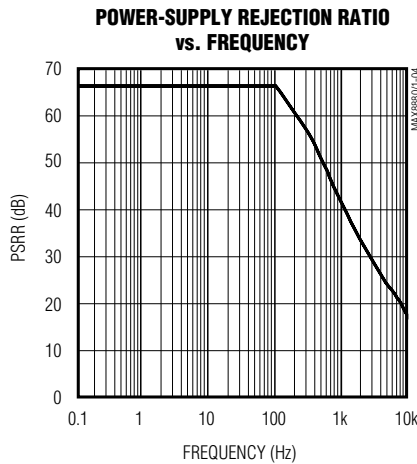
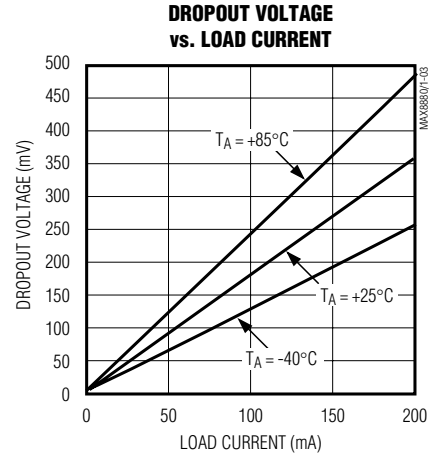
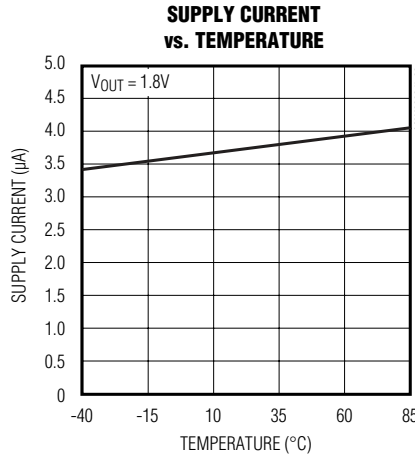
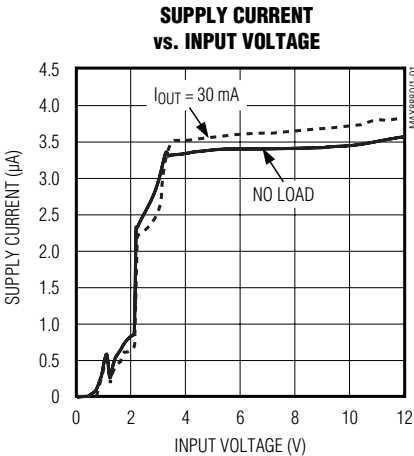

12V, Ultra-Low-I_Q, Low-Dropout Linear Regulators with POK

Typical Operating Characteristics (continued)

(V_{IN} = 5V, V_{OUT} = 3.3V, I_{OUT} = 30mA, C_{OUT} = 4.7μF, T_A = +25°C, unless otherwise noted. See Figure 1.)

OUTPUT VOLTAGE ERROR vs. LOAD CURRENT

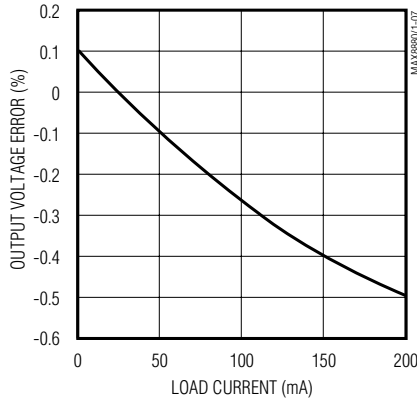

SUPPLY CURRENT vs. LOAD CURRENT

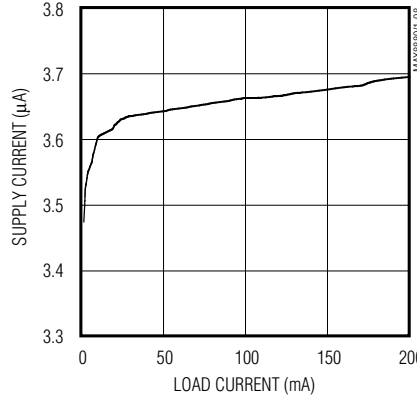

OUTPUT VOLTAGE vs. INPUT VOLTAGE

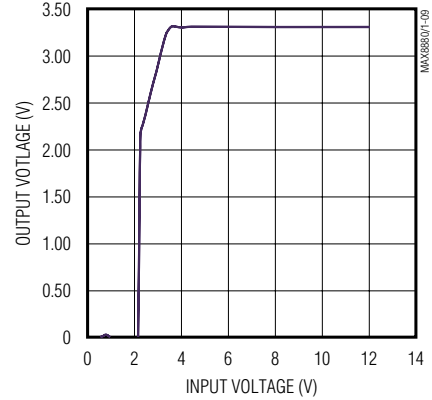

CHANGE FROM NOMINAL OUTPUT VOLTAGE vs. TEMPERATURE

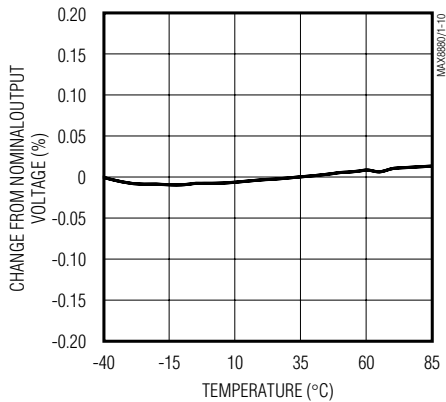

REGION OF STABLE C_{OUT} ESR vs. OUTPUT CURRENT

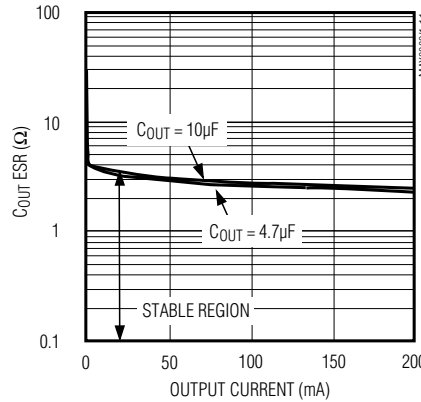

LINE-TRANSIENT RESPONSE

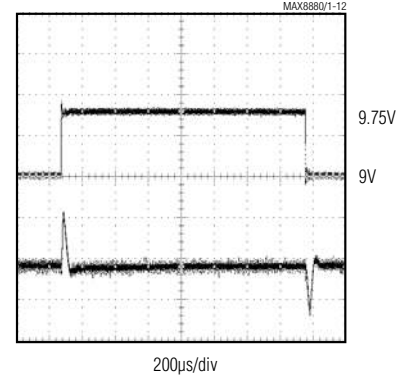

CH1 = V_{IN}, 500mV/div, AC COUPLED
 CH2 = V_{OUT}, 20mV/div, AC COUPLED
 V_{OUT} = 5V, I_{OUT} = 5mA

LOAD-TRANSIENT RESPONSE

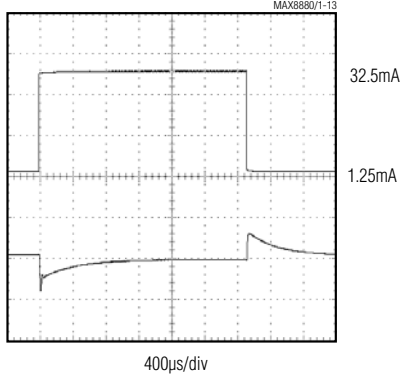

CH1 = I_{OUT}, 12.5mA/div
 CH2 = V_{OUT}, 100mV/div, AC COUPLED
 V_{OUT(NOMINAL)} = 5V, V_{IN} = 9V

LOAD-TRANSIENT RESPONSE NEAR DROPOUT

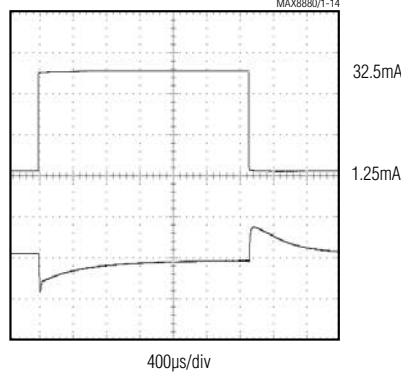

CH1 = I_{OUT}, 12.5mA/div
 CH2 = V_{OUT}, 100mV/div, AC COUPLED
 V_{IN} = 5.2V, V_{OUT(NOMINAL)} = 5V

TURN-ON RESPONSE

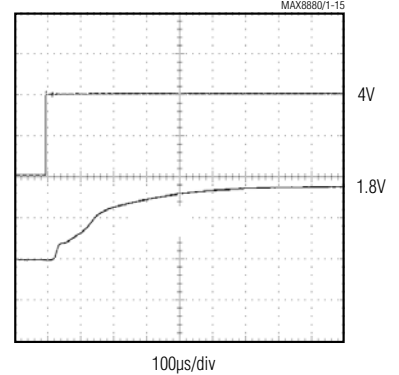

CH1 = SHDN, 2V/div
 CH2 = V_{OUT}, 1V/div
 V_{IN} = 4.0V

12V, Ultra-Low-I_Q, Low-Dropout Linear Regulators with POK

MAX8880/MAX8881

Pin Description

PIN		NAME	FUNCTION
MAX888_ (SOT)	MAX888_ (TDFN)		
1	4	IN	Input Voltage. Bypass with a 1μF capacitor to GND.
2	2	GND	Ground
3	3	OUT	Output Voltage. Bypass with a 4.7μF capacitor (<0.5Ω ESR) to GND for load currents up to 200mA. For load currents up to 40mA, 1μF is acceptable.
4	1	FB	Feedback Set Point, 1.25V (MAX8880 only). Output sense, connect to OUT externally (MAX8881 only).
5	5	$\overline{\text{SHDN}}$	ON/OFF Control. Regulator is ON when $V_{\overline{\text{SHDN}}} > 2\text{V}$. If unused, connect to IN. If reverse battery protection of the $\overline{\text{SHDN}}$ input is desired, connect a 100kΩ resistor in series with $\overline{\text{SHDN}}$.
6	6	POK	POK Output, Open Drain. Low when OUT is out of regulation or in shutdown. Connect POK to OUT through a high-value resistor for a simple error
—	—	EP	Exposed paddle (TDFN only). Connect to the circuit ground plane.

Detailed Description

The MAX8880/MAX8881 are low-dropout, low-quiescent current linear regulators designed primarily for battery-powered applications (Figure 1). The MAX8880 provides an adjustable output voltage from 1.25V to 5V using an external resistor-divider. The MAX8881 is available in factory preset output voltages of 1.8V, 2.5V, 3.3V, and 5V. Both devices have a +1.25V reference, error amplifier, MOSFET driver, and P-channel pass transistor (Figure 2).

Low-Dropout Regulator

The 1.25V reference is connected to the error amplifier's inverting input. The error amplifier compares this reference with the selected feedback voltage and amplifies the difference. The MOSFET driver reads the error signal and applies the appropriate drive to the P-channel pass transistor. If the feedback voltage is lower than the reference voltage, the pass-transistor gate is

pulled lower, allowing more current to pass, increasing the output voltage. If the feedback voltage is higher than the reference voltage, the pass-transistor gate is driven higher, allowing less current to pass to the output. The output voltage is fed back through either an internal resistor voltage divider by externally connecting FB to OUT (MAX8881), or an external resistor network connected to FB (MAX8880). Additional blocks include an output current limiter, reverse battery protection, a thermal sensor, shutdown logic, and a POK comparator to indicate when the output is out of regulation (Figure 2).

Internal P-Channel Pass Transistor

The MAX8880/MAX8881 feature a 2Ω P-channel MOSFET pass transistor. This provides advantages over similar designs using PNP pass transistors, including longer battery life. The P-channel MOSFET requires no base drive, which reduces quiescent current considerably. PNP-based regulators waste considerable current in dropout when the pass transistor saturates. They also use high base-drive currents under large loads. The MAX8880/MAX8881 do not suffer from these problems and consume only 3.5μA of supply current (see *Typical Operating Characteristics*).

Dropout Voltage

A regulator's minimum input-output differential (or dropout voltage) determines the lowest usable supply voltage. In battery-powered systems, this determines the useful end-of-life battery voltage. Because the MAX8880/MAX8881 use a P-channel MOSFET pass transistor, their dropout voltage is $R_{DS(ON)} (2\Omega)$ multiplied by the load current (see *Electrical Characteristics*).

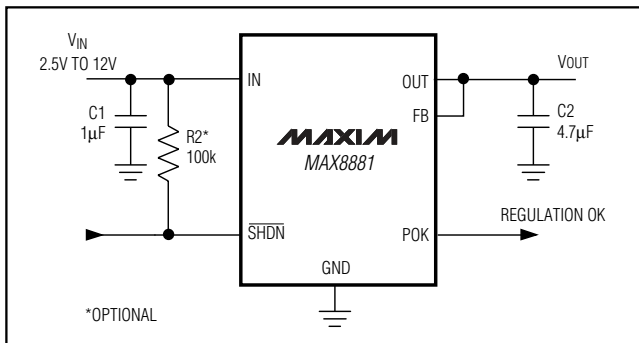

Figure 1. Standard Application Circuit

12V, Ultra-Low-I_Q, Low-Dropout Linear Regulators with POK

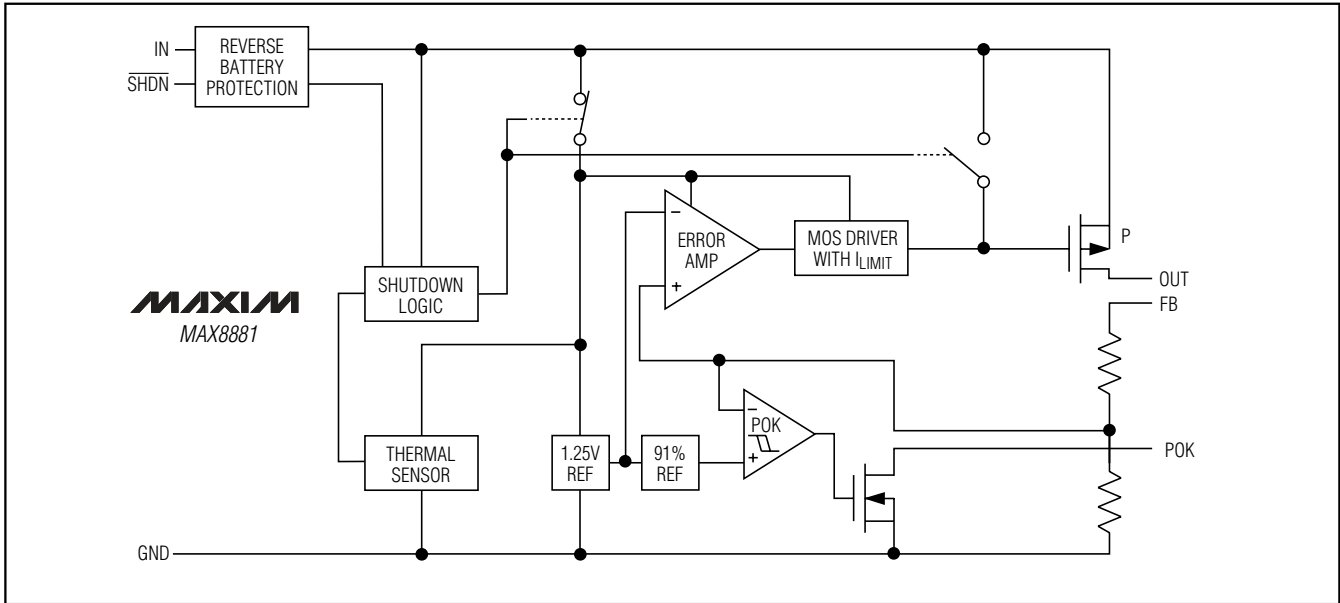

Figure 2. Functional Diagram

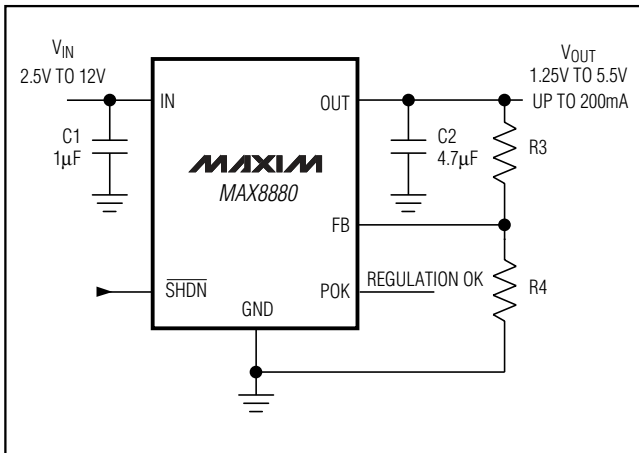

Figure 3. Adjustable Output Using External Feedback Resistors

Reverse Battery Protection

The MAX8880/MAX8881 have a unique protection scheme that limits the reverse supply current to less than 1mA when V_{IN} is forced below ground. The circuit monitors the polarity of V_{IN} , disconnecting the internal circuitry and parasitic diodes when the battery is reversed. This feature prevents the device from electrical stress and damage when the battery is connected backwards. If reverse battery protection is needed, drive \overline{SHDN} through a 100k Ω resistor.

Current Limiting

The MAX8880/MAX8881 include a current limiter. When the output is shorted to ground, drive to the output PMOS is limited. The output can be shorted to ground without damage to the part.

Thermal Overload Protection

Thermal overload protection limits total power dissipation in the MAX8880/MAX8881. When the internal junction temperature exceeds $T_J = +160^\circ\text{C}$, the thermal sensor signals the shutdown logic, turning off the pass transistor and allowing the IC to cool. The thermal sensor turns the pass transistor on again after the IC's junction temperature cools by 15°C , resulting in a pulsed output during continuous thermal-overload conditions.

Thermal-overload protection is designed to protect the MAX8880/MAX8881 in the event of fault conditions. For continuous operation, do not exceed the absolute maximum junction temperature rating of $T_{J(\text{MAX})} = +150^\circ\text{C}$.

Operating Region and Power Dissipation

The MAX8880/MAX8881's maximum power dissipation depends on the thermal resistance of the case and circuit board, the temperature difference between the die junction and ambient air, and the rate of airflow. The power dissipation in the device is $P = I_{OUT} (V_{IN} - V_{OUT})$. The maximum power dissipation allowed is:

12V, Ultra-Low-I_Q, Low-Dropout Linear Regulators with POK

$$R_{MAX} = \frac{(T_{J(MAX)} - T_A)}{(\theta_{JC} + \theta_{CA})}$$

where $T_{J(MAX)} = +150^{\circ}\text{C}$, T_A is the ambient temperature, θ_{JC} is the thermal resistance from the junction to the case, and θ_{CA} is the thermal resistance from the case through the PC board, copper traces, and other materials to the surrounding air.

POK Output

The open-drain POK output is useful as a simple error flag, as well as a delayed reset output. POK sinks current when the output voltage is 10% below the regulation point. Connect POK to OUT through a high-value resistor for a simple error flag indicator. Connect a capacitor in parallel with the resistor to produce a delayed POK signal (delay set by the RC time constant). POK is low during out of regulation or in shut-down and is high impedance during normal operation.

Applications Information

Capacitor Selection and Regulator Stability

The MAX8880/MAX8881 are designed to be stable with an output filter capacitor as low as $1\mu\text{F}$ and an ESR as high as 1Ω . For general purposes, use a $1\mu\text{F}$ capacitor on the device's input and a $4.7\mu\text{F}$ capacitor on the output. Larger input capacitor values and lower ESR provide better supply-noise rejection and transient response. Use a higher value input capacitor ($10\mu\text{F}$ may be necessary) if large, fast transients are anticipated and the device is located several inches from the power source. Use large output capacitors to improve load-transient response, stability, and power-supply rejection. Note that some ceramic dielectric materials (e.g., Z5U and Y5V) exhibit a large temperature coefficient for both capacitance and ESR, and a larger output capacitance may be needed to ensure stability at low temperatures. A $4.7\mu\text{F}$ output capacitor with X7R or X5R dielectrics should be sufficient for stable operation over the full temperature range, with load currents up to 200mA. For load currents up to 40mA, $1\mu\text{F}$ is acceptable. A graph of the Region of Stable C_{out} ESR vs. Output Current is shown in the *Typical Operating Characteristics*.

Output Voltage Selection

The MAX8881 features a preset output voltage. Internal precision feedback resistors set the MAX8881EUT18 output to 1.8V, the MAX8881EUT25 output to 2.5V, the MAX8881EUT33 output to 3.3V, and the MAX8881EUT50

output to 5V. Connect the MAX8881's FB to OUT for proper operation.

The MAX8880 features an adjustable output voltage from 1.25V to 5.5V, using two external resistors connected as a voltage-divider to FB (Figure 3).

The output voltage is set by the following equation:

$$V_{OUT} = V_{FB} \left(1 + \frac{R3}{R4} \right)$$

where typically $V_{FB} = 1.257\text{V}$. Choose $R4 = 1.2\text{M}\Omega$ to optimize quiescent current, accuracy, and high-frequency power-supply rejection. To simplify resistor selection:

$$R3 = R4 \left(\frac{V_{OUT}}{V_{FB}} - 1 \right)$$

The total current through the external resistive feedback and load resistors should be greater than $1\mu\text{A}$. Since the V_{FB} tolerance is typically less than $\pm 1.5\%$, the output can be set using fixed resistors instead of trim pots.

Power-Supply Rejection and Operation from Sources Other than Batteries

The MAX8880/MAX8881 are designed to deliver low-dropout voltages and low quiescent currents in battery-powered systems. Power-supply rejection is -66dB at low frequencies and rolls off with frequencies above 100Hz. At high frequencies, the output capacitor is the major contributor to the rejection of power-supply noise (see Power-Supply Rejection Ratio vs. Frequency in the *Typical Operating Characteristics*).

When operating from sources other than batteries, improve supply-noise rejection and transient response by increasing the value of the input and output capacitors and by using passive filtering techniques.

The MAX8880/MAX8881 load-transient response graphs (see *Typical Operating Characteristics*) show the output response due to changing load current. Reduce overshoot by increasing the output capacitor's value up to $10\mu\text{F}$ and by reducing its ESR.

Chip Information

TRANSISTOR COUNT: 134

12V, Ultra-Low-IQ, Low-Dropout Linear Regulators with POK

Package Information

(The package drawing(s) in this data sheet may not reflect the most current specifications. For the latest package outline information go to www.maxim-ic.com/packages.)

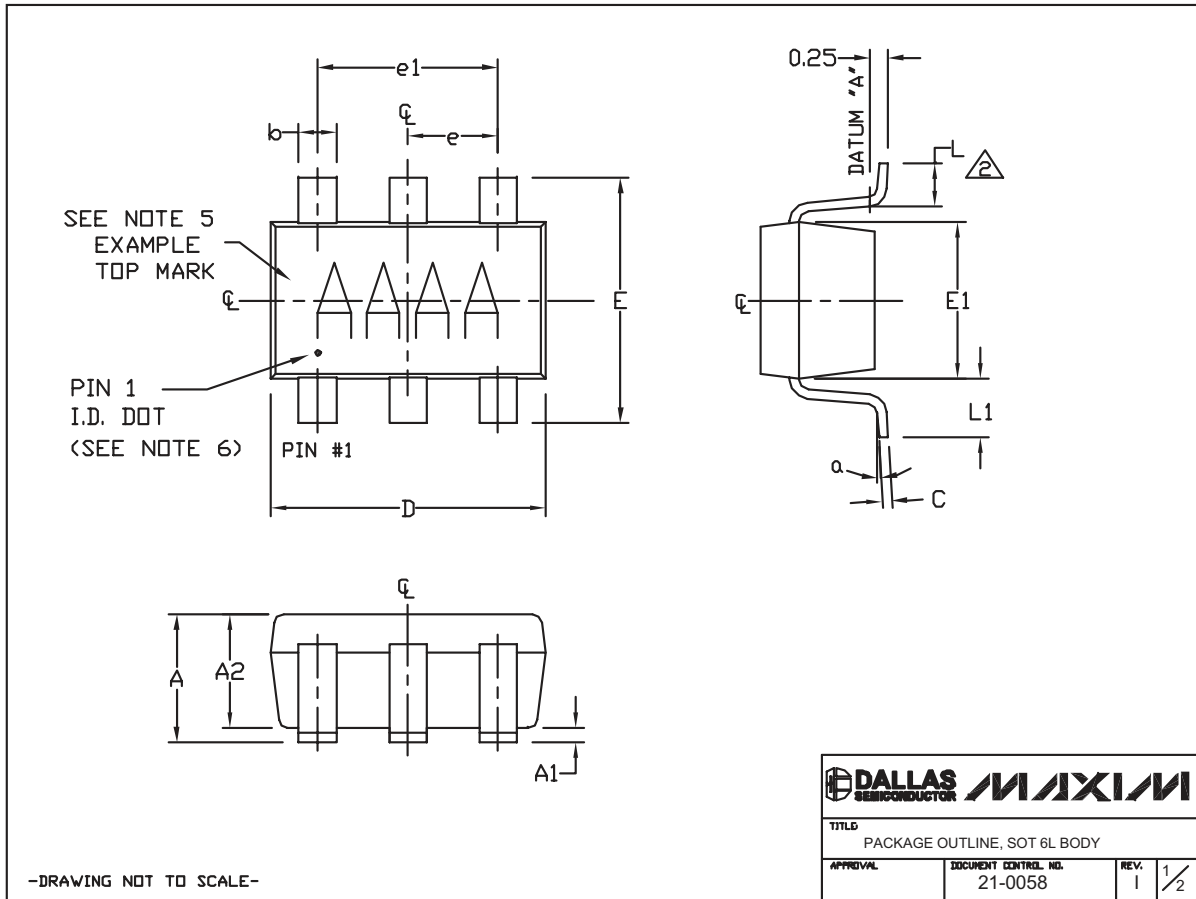

12V, Ultra-Low-Iq, Low-Dropout Linear Regulators with POK

Package Information (continued)

(The package drawing(s) in this data sheet may not reflect the most current specifications. For the latest package outline information go to www.maxim-ic.com/packages.)

MAX8880/MAX8881

NOTES:

1. ALL DIMENSIONS ARE IN MILLIMETERS.
2.  FOOT LENGTH MEASURED AT INTERCEPT POINT BETWEEN DATUM A & LEAD SURFACE.
3. PACKAGE OUTLINE EXCLUSIVE OF MOLD FLASH & METAL BURR. MOLD FLASH, PROTRUSION OR METAL BURR SHOULD NOT EXCEED 0.25mm.
4. PACKAGE OUTLINE INCLUSIVE OF SOLDER PLATING.
5. PIN 1 IS LOWER LEFT PIN WHEN READING TOP MARK FROM LEFT TO RIGHT. (SEE EXAMPLE TOP MARK)
6. PIN 1 I.D. DOT IS 0.3mm ϕ MIN. LOCATED ABOVE PIN 1.
7. MEETS JEDEC MO178, VARIATION AB.
8. SOLDER THICKNESS MEASURED AT FLAT SECTION OF LEAD BETWEEN 0.08mm AND 0.15mm FROM LEAD TIP.
9. LEAD TO BE COPLANAR WITHIN 0.1mm.
10. NUMBER OF LEADS SHOWN ARE FOR REFERENCE ONLY.
11. MARKING IS FOR PACKAGE ORIENTATION REFERENCE ONLY.

SYMBOL	MIN	NOMINAL	MAX
A	0.90	1.25	1.45
A1	0.00	0.05	0.15
A2	0.90	1.10	1.30
b	0.35	0.40	0.50
C	0.08	0.15	0.20
D	2.80	2.90	3.00
E	2.60	2.80	3.00
E1	1.50	1.625	1.75
L	0.35	0.45	0.60
L1	0.60 REF.		
e1	1.90 BSC.		
e	0.95 BSC.		
α	0°	2.5°	10°

PKG CODES:
 U6-1, U6-2, U6-4, U6C-8,
 U6SN-1, U6CN-2, U6S-3, U6F-5,
 U6F-6, U6FH-5, U6FH-6

-DRAWING NOT TO SCALE-

		
TITLE		
PACKAGE OUTLINE, SOT 6L BODY		
APPROVAL	DOCUMENT CONTROL NO.	REV.
	21-0058	1 2/2

12V, Ultra-Low-IQ, Low-Dropout Linear Regulators with POK

Package Information (continued)

(The package drawing(s) in this data sheet may not reflect the most current specifications. For the latest package outline information go to www.maxim-ic.com/packages.)

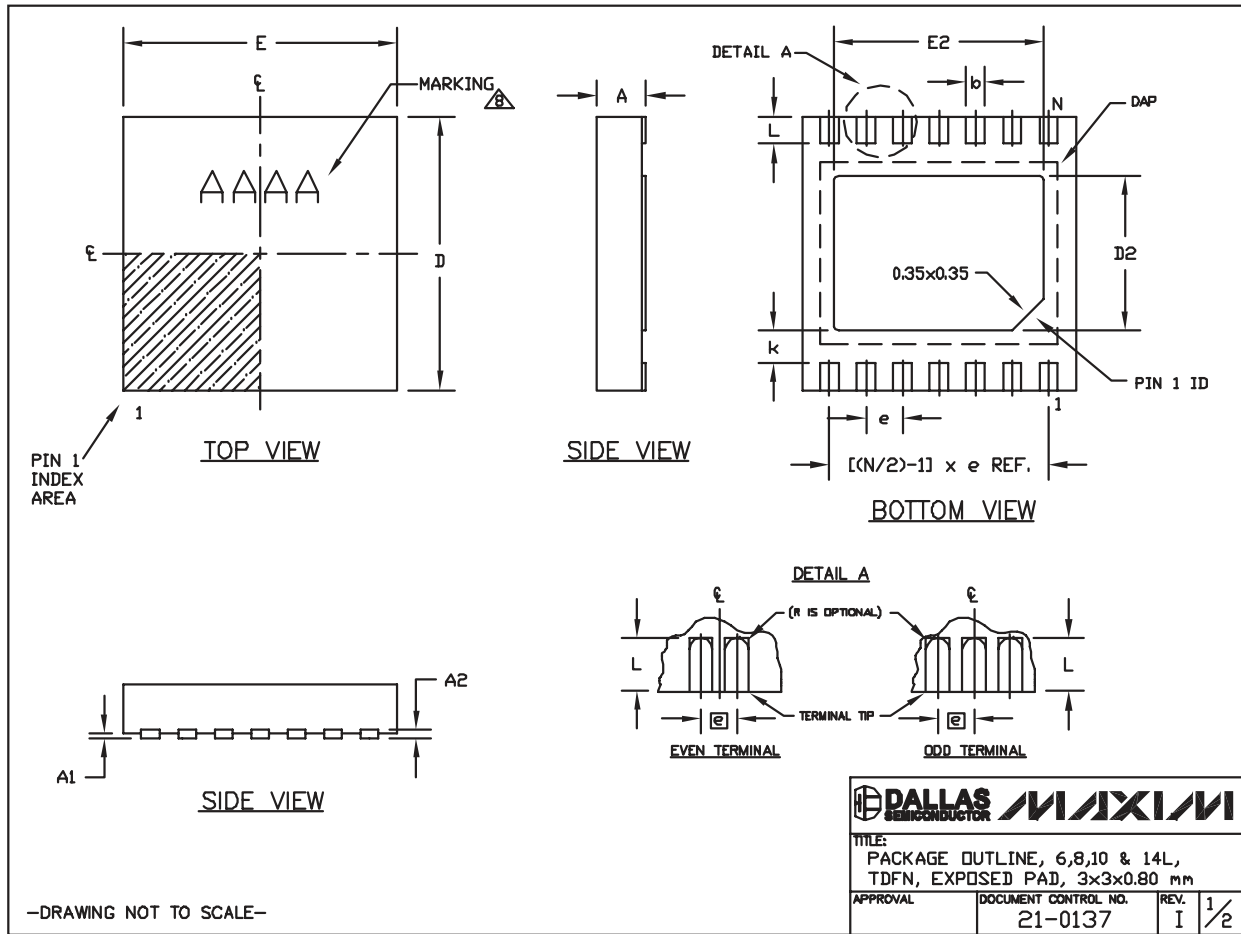

12V, Ultra-Low-Iq, Low-Dropout Linear Regulators with POK

Package Information (continued)

(The package drawing(s) in this data sheet may not reflect the most current specifications. For the latest package outline information go to www.maxim-ic.com/packages.)

MAX8880/MAX8881

COMMON DIMENSIONS		
SYMBOL	MIN.	MAX.
A	0.70	0.80
D	2.90	3.10
E	2.90	3.10
A1	0.00	0.05
L	0.20	0.40
k	0.25 MIN.	
A2	0.20 REF.	

PACKAGE VARIATIONS							
PKG. CODE	N	D2	E2	e	JEDEC SPEC	b	[(N/2)-1] x e
T633-2	6	1.50±0.10	2.30±0.10	0.95 BSC	MO229 / WEEA	0.40±0.05	1.90 REF
T833-2	8	1.50±0.10	2.30±0.10	0.65 BSC	MO229 / WEEC	0.30±0.05	1.95 REF
T833-3	8	1.50±0.10	2.30±0.10	0.65 BSC	MO229 / WEEC	0.30±0.05	1.95 REF
T1033-1	10	1.50±0.10	2.30±0.10	0.50 BSC	MO229 / WEED-3	0.25±0.05	2.00 REF
T1033-2	10	1.50±0.10	2.30±0.10	0.50 BSC	MO229 / WEED-3	0.25±0.05	2.00 REF
T1433-1	14	1.70±0.10	2.30±0.10	0.40 BSC	----	0.20±0.05	2.40 REF
T1433-2	14	1.70±0.10	2.30±0.10	0.40 BSC	----	0.20±0.05	2.40 REF

NOTES:

1. ALL DIMENSIONS ARE IN mm. ANGLES IN DEGREES.
 2. COPLANARITY SHALL NOT EXCEED 0.08 mm.
 3. WARPAGE SHALL NOT EXCEED 0.10 mm.
 4. PACKAGE LENGTH/PACKAGE WIDTH ARE CONSIDERED AS SPECIAL CHARACTERISTIC(S).
 5. DRAWING CONFORMS TO JEDEC MO229, EXCEPT DIMENSIONS "D2" AND "E2", AND T1433-1 & T1433-2.
 6. "N" IS THE TOTAL NUMBER OF LEADS.
 7. NUMBER OF LEADS SHOWN ARE FOR REFERENCE ONLY.
-  MARKING IS FOR PACKAGE ORIENTATION REFERENCE ONLY.

—DRAWING NOT TO SCALE—

		
TITLE: PACKAGE OUTLINE, 6,8,10 & 14L, TDFN, EXPOSED PAD, 3x3x0.80 mm		
APPROVAL	DOCUMENT CONTROL NO. 21-0137	REV. I 2/2

12V, Ultra-Low-IQ, Low-Dropout Linear Regulators with POK

Revision History

REVISION NUMBER	REVISION DATE	DESCRIPTION	PAGES CHANGED
2	12/07	Correction to Pin Description, updated Package Information, incorporated style changes	1, 5, 8-11

Maxim cannot assume responsibility for use of any circuitry other than circuitry entirely embodied in a Maxim product. No circuit patent licenses are implied. Maxim reserves the right to change the circuitry and specifications without notice at any time.

12 _____ **Maxim Integrated Products, 120 San Gabriel Drive, Sunnyvale, CA 94086 408-737-7600**