

724 Workstation Monitor Installation, Operation and Maintenance



Figure 1. SCS 724 Workstation Monitor

Description

The SCS [724](#) Workstation Monitor is intended to monitor the operation of two wrist strap grounding systems and two work surfaces. This product has been designed and tested for use with SCS Dual Conductor Wrist Straps and SCS Work Surfaces Grounding Systems. If the equipment is used in a manner not specified in these instructions, the protection provided by the equipment may be impaired. Use in any other application has not been evaluated by SCS and may lead to an unsafe condition.

Meets requirements of ANSI/ESD S20.20 and recommendations of ESD Handbook ESD TR20.20 which includes “if the products that are being produced are of such value that knowledge of a continuous, reliable ground is needed, and then continuous monitoring should be considered or even required”.

Packaging

- 1 724 Workstation Monitor
- 1 732 Operator Remote
- 1 Power Adapter, North America
- 1 Monitor Ground Cord
- 1 2380D Mat Monitor Cord
- 1 Two-Wire Connector
- 4 Mounting Screws
- 2 Wire Management Clips
- 1 Certificate of Calibration

Theory of Operation

The SCS Workstation Monitor is designed to monitor the operation of the wrist strap grounding systems of two operators. To accomplish this, it uses a DC current source to measure a loop electrical resistance. The system uses a special wristband and ground cord that contain two independent elements. The Workstation Monitor employs two selectable test voltages (9 and 16 volts) and resistance limits (10 Megohms and 35 Megohms). It also monitors the grounding of up to two SCS work surfaces. The Workstation Monitor contains a current-limiting resistor. Resistance is monitored as the Test Voltage passes through one side of the wristband, through the skin of the wearer under the band, through the second side of the wristband, through the second conductor of the ground cord that contains a current-limiting resistor, and finally back to the monitor.

NOTE: There is no power switch or LED power indication light. LED lights will illuminate, verifying power is on, once a wrist strap cord has been inserted.



Figure 2. SCS 724 Workstation Monitor with 732 remote (included) and 733 remote (not included)

Selection of Test Voltage and Resistance Limit

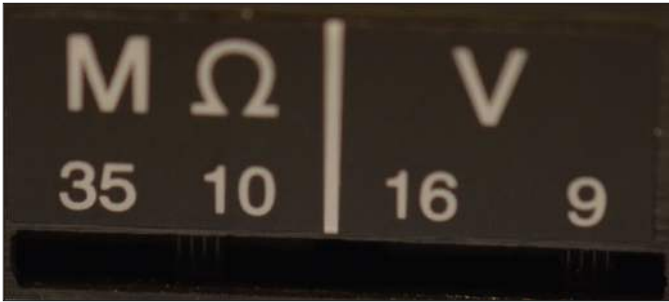

Figure 3. Resistance and test voltage switches

The SCS Workstation Monitor allows for the selection of test voltages (9V or 16V) and resistance limits (10 Megohms or 35 Megohms). The additional ranges have been added to accommodate global electrical static discharge requirements. Selection of the operating parameters are left up to the user's discretion.

Operator Monitoring: Single and Dual

The wrist strap monitoring function is activated by plugging a wrist strap dual conductor ground cord into either one of the jacks on the SCS [732](#) or [733](#) Operator Remote. If the resistance of the wrist strap loop is within the limits of the selected range (1.5 Megohms to 10 Megohms or 1.5 Megohms to 35 Megohms) on the Workstation Monitor, the cord, the wristband, and the contact to the arm of the wearer, it is considered to be functioning correctly. At this time, one of the (OK) green lamps (1 or 2) will be illuminated on the front of the monitor.

The wrist strap of the second operator is measured in the same way. Operators are identified by the two (OK) green lamps (1 & 2). However, the same high wrist strap red lamp (H) and low yellow (L) lamps illuminate when a fault is detected. The green lamp that extinguishes identifies the operator that is experiencing the fault condition.



Figure 4. SCS 724 Workstation Monitor features and components

If the resistance of the wrist strap loop is higher than the selected range (10 Megohms or 35 Megohms) on the Workstation Monitor, an (OK) wrist strap green lamp (1 or 2) extinguishes, and a high wrist strap red lamp (H) illuminates with an audible alarm. This is an indication of a high resistance in the wristband, or poor contact between arm and band. If the resistance in the loop is under 1.5 Megohms, it is an indication of a low resistance meaning one or both current-limiting resistors are bypassed. The low yellow lamp (L) will flash and an (OK) green lamp (1 or 2) will remain illuminated.

Voltage on Operator When Connected to the SCS 724 Workstation Monitor

There is a concern about the voltage that is applied to an operator while they are connected to a monitor. Some of today's electronic components are extremely sensitive to electrostatic discharge from a person (less than 10 volts). The user should determine if these voltages can damage the device being handled. The following chart for the Workstation Monitor illustrates the level of voltage that will appear on the operator under various resistance conditions.

A low resistance condition also can be caused by touching a grounded object or by standing on a conductive surface. This may trigger the low resistance alarm on the SCS Workstation Monitor.

| Condition | 9V-10 Megohms | 9V-35 Megohms | 16V-10 Megohms | 16V-35 Megohms |
|--------------------------|---------------|---------------|----------------|----------------|
| No Skin Resistance | 0.9V | 0.9V | 1.6V | 1.6V |
| 200K Ohm Skin Resistance | 1.0V | 1.0V | 1.8V | 1.8V |
| Likely Case Before Alarm | 2.5V | 3.6V | 4.4V | 6.4V |
| Worst Case Before Alarm | 4.5V | 7.1V | 8.0V | 12.6V |
| Absolute Worst Case | 9.0V | 9.0V | 16.0V | 16.0V |

NOTE: For more information about wrist strap monitoring, see Additional Wrist Strap Monitoring Information.

Audible Alarm Tones

For wrist strap malfunctions the SCS Workstation Monitor indicates a different tone for each operator – a continuous tone for #1 operator and a fast chirping beep for #2 operator. The volume of the wrist strap alarm is adjusted by selection of the internal DIP switch #1. For work surface malfunctions, a slow chirping beep is made. This alarm sound is turned on or off by selection of DIP switch #2. Switch #1 and #2 are accessible through a slot located in the bottom of the chassis.

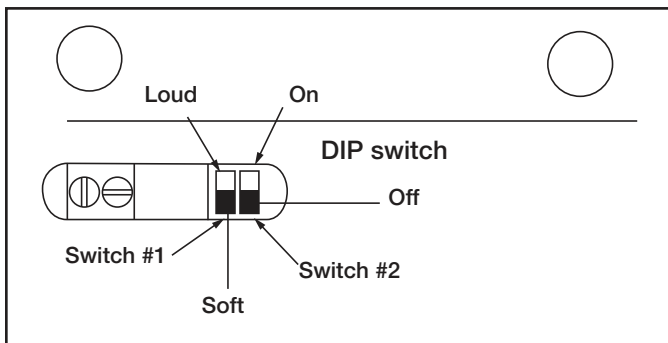

Figure 5. Selected desired alarm options.

Worksurface Monitoring

The Workstation Monitor monitors its connection to ground and the grounding of an SCS ESD work surface. A loop resistance is measured from the monitor, through an SCS Monitor/Table Mat Cord 2380D to the work surface (See page 3, column 2), across the conductive layer of the work surface, through the grounding wire of the work surface to an electrical ground and finally back to the monitor through the Workstation Monitor grounding wire. If the resistance of the loop exceeds 3.7 Megohms the work surface high red lamp (M) will illuminate and all green lamps will be extinguished.

If DIP switch #2 is in the ON position (Figure 5) the audible alarm will activate. If no ESD work surface is to be monitored, the Monitor/Table Mat Cord 2380D and the ground wire of the Workstation Monitor must be connected to an electrical ground (See page 4, column 1). This is done to ensure that the Workstation Monitor is providing a ground connection for the operators. Again, if the loop resistance exceeds 3.7 Megohms the work surface high red lamp (M) will illuminate and the alarm will activate if selected. 2380 Mat Cord (without resistor) can also be used with the Workstation Monitor. It can be used when the surface resistance threshold of 3.7 Megohms is reached using the 2380D.

The grounding wire from the work surface and the ground wire from the SCS Workstation Monitor must be attached to separate electrical grounds. The work surface monitoring function is active any time that the power supply for the monitor is plugged in.

Disconnect the SCS Monitor/ Table Mat Cord 2380D to prevent possible damage to the SCS Workstation Monitor before testing the resistance of the work surface with a high voltage megohmmeter.

Installation of SCS 724 Workstation Monitor with Worksurface Ground Monitoring

Wire Attachments and Grounding - See Figure 13 for complete drawing of the Workstation wire connections.

Tools required – Small blade, screwdriver and wire cutter.

- Use a one megohm mat ground cord such as the SCS 3040 to connect your worksurface mat to electrical ground.
- Using a small screwdriver move the DIP switch #2 on the Workstation Monitor to the ON position to activate the work surface audible alarm (Figure 5).
- Locate the accessory package that contains an SCS Monitor/Table Mat Cord 2380D, Workstation Monitor ground wire (with ring terminal), and the two-wire connector plug.
- Attach the SCS Monitor/Table Mat Cord 2380D (tinned wire end) to the work surface terminal of the two-wire connector by inserting it into opening and securing with the screwdriver (Figure 6A or 6B). Attach the plastic cap end to the snap on the work surface.
- Determine how you want to ground the Workstation Monitor:
 - If you are grounding through the AC adapter perform step (f).
 - If you are grounding through the Workstation Monitor ground wire perform step (g).

- f) Attach the tinned ground wire of the AC adapter to the ground terminal of the two-wire connector by inserting it into opening and securing with screwdriver (Figure 6B). Continue with step (h).
- g) Attach the tinned Workstation Monitor ground wire to the ground terminal of the two-wire connector by inserting the tinned end into opening and securing with screwdriver (Figure 5A). Attach the ring terminal end with a screw (not supplied) to an electrical ground (Figure 8B). Continue with step (h).
- h) Plug the two wire connector into the jack at the rear of the SCS Workstation Monitor (Figure 8).
- i) Insert the plug connector of the SCS 732 Operator Remote cable into the 732 jack at the rear of the Workstation Monitor (Figure 10).
- j) Insert the round connector from the AC adapter into the jack at the rear of the Workstation Monitor.

NOTE: Two snap fasteners or appropriate connectors must be installed at opposite corners of the work surface to use this feature. For recommended surfaces to use with the SCS Workstation Monitor refer to item table on page 10. Use of an SCS Female Snap Fastener 3034 or 3050 (depending on the type of surface) is recommended for connection to the SCS Monitor/Table Mat Cord 2380D that is supplied with the Workstation Monitor. If you are using the SCS Dissipative Hard Laminate Material 8300, attach the Monitor/Table Mat Cord 2380D to suitable hardware used to make an electrical connection to the ground layer of the work surface. This may require you to cut off the plastic cap end of the Monitor/Table Mat Cord 2380D.

If for any reason a snap fastener cannot be used on the work surface, the plastic cap on the end of the SCS Monitor/Table Mat Cord 2380D can be cut off and replaced with a ring terminal not supplied (Figure 7).

Disconnect the SCS Monitor/Table Mat Cord 2380D to check for visual and audible high work surface alarm condition and reconnect. If the high work surface lamp (M) is on before removing the Monitor/Table Mat Cord 2380D, check for loose connections or high resistance to ground (>3.7 Megohms). Disconnect the Monitor/Table Mat Cord 2380D from the work surface and check the resistance to ground by attaching one lead of an ohmmeter to the connector on the work surface and the other lead to ground.

Installation of SCS 724 Workstation Monitor without Worksurface Ground Monitoring

Wire Attachments and Grounding – See Figure 13 for complete drawing of Workstation Monitor wire connections.

Tools required – Small blade, screwdriver, and wire cutter.

- a) Using a screwdriver move DIP switch #2 on the Workstation Monitor to the OFF position to deactivate the work surface audible alarm (Figure 5).
- b) Locate the accessory package that contains an SCS Monitor/Table Mat Cord 2380D, Workstation Monitor ground wire (with ring terminal), and the two-wire connector plug.
- c) Attach the Monitor/Table Mat Cord 2380D (tinned wire end) to the work surface terminal of the two-wire connector plug by inserting into opening and securing with screwdriver (Figure 6A or 6B).
- d) Cut off the plastic cap on the end of the SCS Monitor/Table Mat Cord 2380D and strip off approximately 1/2 inch of insulation and twist the stranded wire together (Figure 6). Attach this end to an electrical ground using a ring terminal (not supplied) or by wrapping the wire around the head of a screw (Figure 8A).
- e) Determine how you want to ground the SCS Workstation Monitor:
 - If you are grounding through the AC adapter, perform Step (f).
 - If you are grounding through the Workstation Monitor ground wire, perform Step (g).
- f) Attach the tinned ground wire of the AC adapter to the ground terminal of the two-wire connector by inserting into opening and securing with screwdriver (Figure 6B). Continue with Step (h).
- g) Attach the tinned Workstation Monitor ground wire to the ground terminal of the two-wire connector by inserting the tinned end into opening and securing with screwdriver (Figure 6A). Attach the ring terminal end with a screw (not supplied) to an electrical ground (Figure 8B). Continue with Step (h).
- h) Plug the two wire connector into the jack at the rear of the Workstation Monitor monitor (Figure 9).

NOTE: Do not physically connect the SCS Monitor/Table Mat Cord 2380D and the SCS Workstation Monitor ground wire together. The ground wire for the work surface and the ground wire from the Workstation Monitor must be attached to separate electrical grounds. However, by attaching the wires to the same ground but at a different physical location, the Workstation Monitor can check for loose or lost connections to ground. This would be indicated by the high red work surface lamp (M) illuminating.

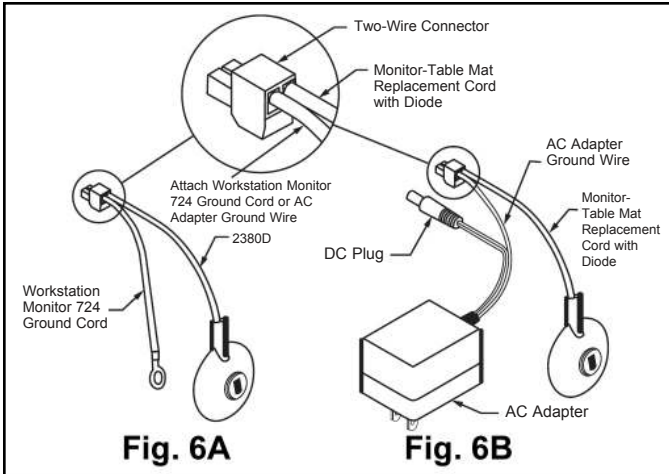

Figure 6A & 6B. Attaching ground wire/cord and worksurface cord to two-wire connector.



Figure 8B. Grounding the SCS 724 Workstation Monitor



Figure 7. Cutting off table mat ground snap.



Figure 9. Inserting two-wire connector into rear of SCS 724 Workstation Monitor



Figure 8A. Attaching system grounds. Note work, surface and unit are grounded at different locations.

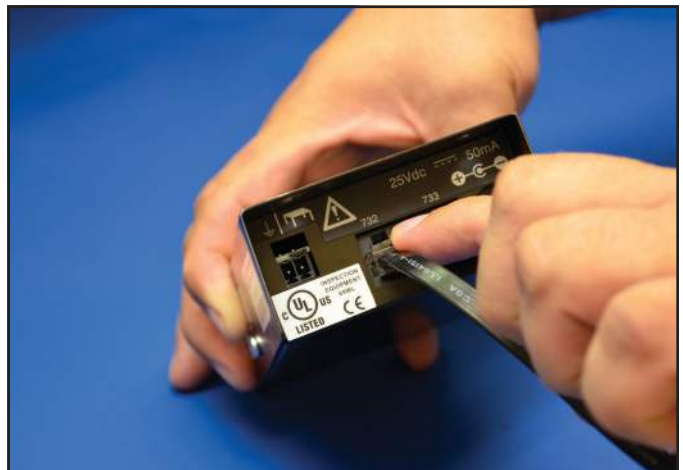

Figure 10. Connecting the 732 Operator Remote to the 724 Workstation Monitor

Selection of Test Voltage and Resistance Limit

Tools required – Small blade, screwdriver.

The SCS Workstation Monitor allows for the selection of test voltages (9V or 16V) and resistance limits (10 Megohms or 35 Megohms). The additional ranges have been added to accommodate global ESD requirements. Selection of the operating parameters are left up to the user's discretion.

- a) Select the desired resistance and voltage limit by moving the appropriate slide switch (with screwdriver) on the side of the Workstation Monitor to the desired position (Figure 3).

Mounting the SCS 724 Workstation Monitor and SCS 732 Operator Remote

- a) Mount or position the Workstation Monitor so that the lamps are easily viewed by the operator (Figs. 10 and 11). Mount the Workstation Monitor to the underside of a work bench top or shelf through the two holes located at the top rear of the case using the two screws supplied. If using the screws is not possible, apply an appropriate amount of durable, double-sided adhesive foam tape to the case.



Figure 11. SCS 724 Workstation Monitor mounted on benchtop.

- b) Locate the Dual Conductor Remote Input Jack 732 so that it is convenient for the operators to attach their wrist strap ground cord. Mount the remote with the screws provided.



Figure 12. SCS 724 Workstation Monitor mounted under shelf or bench.

- c) Plug the AC adapter into a 3-prong grounded outlet (North American System). Outside North America use appropriate AC adapter (see specifications Section 11). The SCS Workstation Monitor is ready for use.

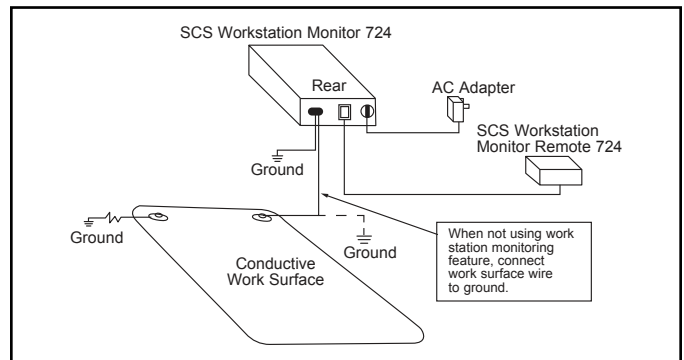

Figure 13. SCS 724 Workstation Monitor installation diagram for single workstation.

Wrist Strap Connection

- a) Attach an SCS Dual Conductor Ground Cord to an SCS Dual Conductor Wristband. Plug the cord into either of the two jacks on the SCS Dual Conductor Remote Input Jack 732 (Figure 14). Plugging into a jack activates the monitor for that input.
- b) The high wrist strap red lamp (H) should illuminate and the corresponding audible alarm for the input (1 or 2) should sound indicating proper functioning of the monitor.
- c) Slip the wristband on your wrist. The alarm should quiet and the wrist strap high red lamp (H) should slowly extinguish. The corresponding OK wrist strap green lamp (1 or 2) should illuminate.



Figure 14. Connecting a wrist cord to the SCS 732 Operator Remote

Fault Conditions

Red Wrist Strap Lamp (H) Accompanied by an Audible Alarm

This indicates that a high resistance condition (greater than 10 Megohms or 35 Megohms) exists for an operator or wrist strap assembly. If two operators are connected to the monitor the high condition is with the operator whose green lamp has extinguished. Check the operator for good contact between the wrist and band. Check the ground cord and connections for continuity. Some operators have difficulty in providing sufficient continuity to the wristband due to dry skin or arm hair. They may need to use an approved skin moisturizer or reposition the wristband on the arm.

Yellow Wrist Strap Lamp (L) with no Audible Alarm

This indicates that a low resistance condition (less than 1.5 Megohms) exists between the operator and ground. One or both of the one megohm current-limiting resistors are being bypassed. A low resistance condition can be caused by touching a grounded object or by standing on a conductive surface.

Red Worksurface Lamp (M)

This indicates that a high resistance condition (> 3.7 Megohms) exists across the conductive layer of the work surface and/or the ground connections. Check the work surface, ground cords, and the connections for continuity. Note the audible alarm may also sound if selected.

Note: The operators may complain that the alarm is sounding too often until they learn to adjust the wristband to fit securely or apply an approved skin moisturizer on a frequent basis. Remember that the monitor is informing you that the operator is exceeding the established static control requirement for resistance to ground when wearing a static protective wrist strap assembly. These alarms alert the operator when sensitive electronics are possibly being exposed to static electricity. Prior to incorporating the work station monitor into your static control process, the operator was unaware of these events.

SCS 3057 Standby Jack

Since the activating switches are located in the SCS 732 and 733 Operator Remotes, the normal operating procedure is for the operators to disconnect their cords from the remotes when leaving the work station. However, an optional Standby Jack that allows the wrist strap ground cord to remain plugged into the remotes is available. Simply attach it to any convenient location then disconnect the cord from the wristband and attach it to the standby jack. The OK green lamp (1 or 2) on the SCS Workstation Monitor will illuminate upon connection. The low yellow lamp (L) will slowly flash if the standby jack is grounded. It can be grounded by attaching a ground wire to the screws or back plate. It can also be grounded if the plate is attached to a grounded metal surface. The operator should reconnect the wrist strap ground cord to their wristband upon returning to the workstation.

SCS 733 Operator Remote

The SCS 733 Operator Remote is used to separate the two wrist strap jacks on the 732 Operator Remote that connect to a Workstation Monitor. This provides a separation up to approximately 10 feet apart. This is done using the SCS 733 in conjunction with the SCS 732 originally supplied with the Workstation Monitor. Two separate workstations can also be created using the 733 Operator Remote and the SCS 2389 Monitor/Table Mat Interconnect Cord (10 ft.). Instructions for creating two separate workstations are included with the purchase of the SCS 2389 Monitor/Table Mat Interconnect Cord (Figure 16).

Installation of SCS 733 Operator Remote

- a) Insert the plug connector of the 733 Operator Remote cable into the 733 jack at the rear of the SCS Workstation Monitor (Figure 15).
- b) Fully insert the small plastic plug that comes with the kit into the #2 wrist strap input on the 732 Operator Remote. This disables the #2 input and prevents a situation where two users would simultaneously attempt to use the input lines to the Workstation Monitor.
- c) Position and mount both remote input jacks in convenient locations.

Verification Procedure for the 724 Workstation Monitor

The Workstation Monitor cannot be recalibrated after the initial factory calibration. However, the following steps can be used to determine if the Workstation Monitor is operating within its specifications.

Equipment Needed:

- Small blade screwdriver.
- Resistance Substitution Box (RSB), 1 Ohm to 45 Megohms $\pm 1\%$.
- One two-conductor cable with standard 3.5 mm (miniature) phone plug attached on one end and appropriate connectors on the other end to connect to RSB.

Note: Two-conductor cable must have an isolation resistance of >1 Gigohm between conductors. Two separated wires may also be used to obtain higher isolation resistance.

- Two wires with alligator clips.
- Ohmmeter capable of measuring to 45 Megohms $\pm 0.5\%$, to verify the RSB.

Procedure

Worksurface

- Access the dual inline package (DIP) switches SW1 and SW2 through a slot located at the bottom of the chassis. Adjust SW1 to the LOUD position and SW2 to the ON position with a small screwdriver (Figure 5).
- Plug in the AC adapter. Note that the red high work surface lamp (M) is illuminated with an audible alarm (slow chirping beep).
- Adjust DIP switch SW1 to the SOFT position. Note that the loudness of the alarm decreases.
- Adjust DIP switch SW2 to the OFF position. Note that the audible alarm is silenced.
- Attach the SCS Monitor/Table Mat Cord 2380D and the SCS Workstation Monitor ground wire to the RSB using the two wires with alligator clips. Set the resistance as follows and observe Workstation Monitor output:
 - 3.1 Megohms – Red work surface lamp (M) OFF.
 - 4.3 Megohms – Red work surface lamp (M) ON.
- Disconnect the cords from the RSB.
- Connect the ring terminal end of the Workstation Monitor ground wire to the metal snap of the Monitor/Table Mat Cord 2380D. The red work surface lamp (M) should now be OFF.

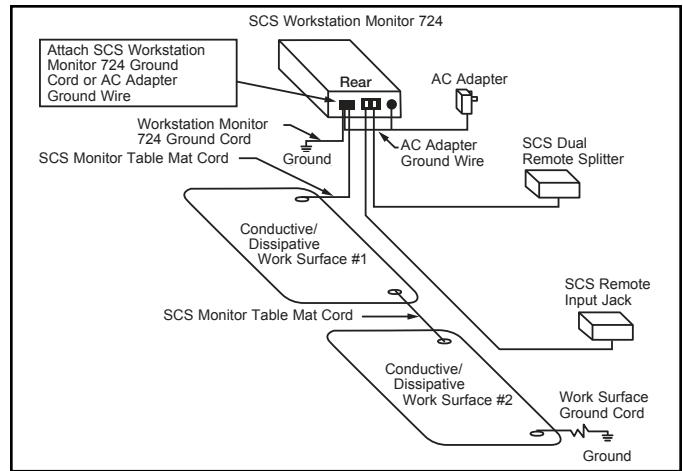

Figure 15. SCS 724 Workstation Monitor installation diagram for two workstations.

Wrist Strap

Set Resistance Limit 10 Megohms and Test Voltage 9V (Figure 3).

- Connect the two-wire cable with 3.5 mm phone plug into the #1 input of the 732 Operator Remote and attach the other end to the RSB. Set the resistance as follows and observe the Workstation Monitor output:
 - 1.3 Megohms – Yellow low lamp (L) flashing, green (OK) lamp (1) ON, and audible alarm OFF.
 - 1.7 Megohms – Yellow low lamp (L) OFF, green (OK) lamp (1) ON, and audible alarm OFF.
 - 8.5 Megohms – High red wrist strap lamp (H) OFF, green (OK) lamp (1) ON, and audible alarm OFF.
 - 11.5 Megohms – High red wrist strap lamp (H) ON, audible alarm ON (continuous tone), and green (OK) lamp (1) OFF.
- Repeat step (h) for input #2 of 732 Operator Remote. Audible alarm will be a fast chirping beep.

Set Resistance Limit 35 Megohms and Test Voltage 9V (Figure 3).

j) Test as in step (h) above. However, set the resistance as follows and observe the Workstation Monitor output:

- 1.3 Megohms – Yellow low lamp (L) flashing, green (OK) lamp (1) ON, and audible alarm OFF.
- 1.7 Megohms – Yellow low lamp (L) OFF, green (OK) lamp (1) ON, and audible alarm OFF.
- 29.8 Megohms – High red wrist strap lamp (H) OFF, green (OK) lamp (1) ON, and audible alarm OFF.
- 40.2 Megohms – High red wrist strap lamp (H) ON, audible alarm ON (continuous tone), and green (OK) lamp (1) OFF.

k) Repeat step (j) for input #2 of the 732 Operator Remote. Audible alarm will be fast chirping beep.

Set Resistance Limit 10 Megohms and Test Voltage 16V (Figure 3).

l) Connect the two-wire cable with 3.5 mm phone plug into the #1 input of the 732 Operator Remote and attach the other end to the RSB. Set the resistance as follows and observe the Workstation Monitor output:

- 1.3 Megohms – Yellow low lamp (L) flashing, green (OK) lamp (1) ON, and audible alarm OFF.
- 1.7 Megohms – Yellow low lamp (L) OFF, green (OK) lamp (1) ON, and audible alarm OFF.
- 8.5 Megohms – High red wrist strap lamp (H) OFF, green (OK) lamp (1) ON, and audible alarm OFF.
- 11.5 Megohms – High red wrist strap lamp (H) ON, audible alarm ON (continuous tone), and green (OK) lamp (1) OFF.

m) Repeat step (l) for input #2 of the 732 Operator Remote. Audible alarm will be fast chirping beep.

Set Resistance Limit 35 Megohms and Test Voltage 16V (Figure 3).

n) Test as in step (l) above. However, set the resistance as follows and observe the Workstation Monitor output:

- 1.3 Megohms - Yellow low lamp (L) flashing, green (OK) lamp (1) ON, and audible alarm OFF.
- 1.7 Megohms - Yellow low lamp (L) OFF, green (OK) lamp (1) ON, and audible alarm OFF.
- 29.8 Megohms - High red wrist strap lamp (H) OFF, green (OK) lamp (1) ON, and audible alarm OFF.
- 40.2 Megohms - High red wrist strap lamp (H) ON, audible alarm ON (continuous tone), and green (OK) lamp (1) OFF.

o) Repeat step (n) for input #2 of the 732 Operator Remote. Audible alarm will be fast chirping beep.

Specifications

| | | |
|--|---|---|
| Workstation Monitor Dimensions | 6.5" x 3.125" x 1.375" (16.5 x 7.9 x 3.5 cm) | |
| Operator Remote Dimensions | 2.75" x 1.0" x 1.0" (7.0 x 2.5 x 2.5 cm) | |
| Power Adapter Requirements (North American power adapter included)* | Input: 100-120 VAC 50/60 Hz | Output: 25 VDC @ 50 mA rated load |
| Output Plug Polarization | Center Negative | |
| Output Plug Dimensions | 5.5 mm O.D. x 2.1 mm I.D. x 9.5 mm Length | |
| Test Voltage | 9 VDC / 16 VDC Open circuit (Typical Value) | |
| Test Current | Less than 3 microamps (Typical Value) | |
| Environmental Operating Conditions | Indoor use only | |
| Temperature | Maximum: 110°F / 43°C | Minimum: 50°F / 10°C |
| Humidity | Maximum relative humidity 80% for temperatures up to 31°C to 50% relative humidity at 40°C. | |

*SCS [724-PSEU](#) Power Adapter with UK / Europe Plugs sold separately

Accessories

| Item | Description | Size |
|------------------------|---|---|
| 4720 | Dual Conductor Wristband, Blue (ground cord not included) | Adjustable |
| 2368 | Dual Conductor Fabric Wristband | Adjustable |
| 2381 | Dual Conductor Metal Wrist Strap** | Small |
| 2382 | Dual Conductor Metal Wrist Strap** | Medium |
| 2383 | Dual Conductor Metal Wrist Strap** | Large |
| 2384 | Dual Conductor Metal Wristband | Small |
| 2385 | Dual Conductor Metal Wristband | Medium |
| 2386 | Dual Conductor Metal Wristband | Large |
| 2360 | Dual Conductor Coil Cord | 5' (1.5 m) |
| 2370 | Dual Conductor Coil Cord | 10' (3.0 m) |
| 2371 | Dual Conductor Coil Cord | 20' (6.0 m) |
| 2389 | Mat Interconnection Cord | 10' (3.0 m) |
| 3040 | Mat Ground Cord with 1 Megohm Resistor | 15' (4.6 m) |
| 3057 | Stand-By Jack | 1.9" x 1.3" x 1.1" (4.8 x 3.3 x 2.8 cm) |
| 732 | Replacement Remote Input Jack | 6.5" x 3.1" x 1.4" (16.5 x 7.9 x 3.5 cm) |
| 733 | Dual Remote Splitter Kit | 6.5" x 3.1" x 1.4" (16.5 x 7.9 x 3.5 cm) |
| 770037 | Rear Terminal Block, 2 Pin, Pack of 5 | N/A |

| Item | Description | Size |
|---------------------------|--|---------------|
| 8800 | Two-Layer Rubber Mats, Premium | Various Sizes |
| Ultra R-2 | Ultra R-2 Two-Layer Rubber Mat L2RGR, Standard | Various Sizes |
| | Ultra R-2 Two-Layer Rubber Mat L2RBL, Standard | Various Sizes |
| | Ultra R-2 Two-Layer Rubber Mat L2RGN, Standard | Various Sizes |
| 8200 | Three-Layer Vinyl Mats, Premium | Various Sizes |
| Premium | Three-Layer Vinyl Mats L3GR, Standard | Various Sizes |
| | Three-Layer Vinyl Mats L3BL, Standard | Various Sizes |
| 1864 | Conductive Black Plastic/Rubber Mat | Various Sizes |
| 9900 | Conductive Black Anti-Fatigue Mat | Various Sizes |
| COND | Conductive Black Rubber Mat FM Economy | Various Sizes |

**Includes wristband & cord

Only accessories, optional parts and replacement parts supplied or specified by SCS Company shall be used with this product.

Use only a clean dry cloth to clean the SCS Workstation Monitor.

Environmental Conditions

Industry Canada standard ICES-003 This Class B digital apparatus complies with Canadian ICES-003. Cet appareil numérique de la classe B est conforme à la norme NMB-003 du Canada.

This equipment has been tested and found to be safe to operate within these environmental conditions. This is not a warranty of equipment performance within these conditions.

- Indoor use only.
- Ingress Protection: IPX0.
- Altitude: Up to 2187 yards (2,000 m).
- Transient overvoltages up to the levels of overvoltage category II.
- Pollution degree 2.
- Temperature: Maximum 110°F / 43°C
Minimum 50°F / 10°C.
- Humidity: Maximum relative humidity 80% for temperatures up to 31°C. Decreasing linearly to 50% relative humidity at 40°C.

Safety Information

WARNING

To reduce the risks associated with fire and explosion:

- Do not use in an explosive environment - monitor is not designed to be intrinsically safe.

To reduce the risks associated with medical device malfunction:

- Persons with heart pacemaker devices should never use this monitor.

To reduce the risks associated with hazardous voltage and fire:

- Use only the power supply provided by SCS and specified for the country of use.
- Do not position the monitor accessories or other equipment where unplugging the power supply is difficult.
- Always locate the power source (socket or outlet) near the equipment. The power supply plug serves as the disconnect device.
- Do not modify or attempt to service the power supply or monitor; there are no user serviceable parts.
- Do not use the power supply if damaged;
- Replace power supply if damaged using only 3M supplied parts.
- Do not use the SCS Workstation Monitor or its power supply outdoors in wet/humid environments.
- Do not use the Workstation Monitor or its power supply outside of the operating

CAUTION

To reduce the risks associated with environmental contamination:

- Dispose of this monitor in accordance with all applicable local and government regulations.

NOTICE

To reduce the risk of ESD damage to components or assemblies being handled:

- Monitor must be checked periodically to verify each test mode is functioning correctly.
- Ensure proper operation of monitor by performing operational verification test as required.
- Ensure tester is properly grounded.

WEEE Statement

The following information is only for EU-member States: The mark shown to the right is in compliance with Waste Electrical and Electronic Equipment Directive 2002/96/EC (WEEE). The mark indicates the requirement NOT to dispose the equipment as unsorted municipal waste, but use the return and collection systems according to local law.

FCC

This equipment has been tested and found to comply with the limits for a Class B digital device, pursuant to part 15 of the FCC Rules. These limits are designed to provide reasonable protection against harmful interference in a residential installation. This equipment generates, uses and can radiate radio frequency energy and, if not installed and used in accordance with the instructions, may cause harmful interference to radio communications. However, there is no guarantee that interference will not occur in a particular installation. If this equipment does cause harmful interference to radio or television reception, which can be determined by turning the equipment off and on, the user is encouraged to try to correct the interference by one or more of the following measures:

- Reorient or relocate the receiving antenna.
- Increase the separation between the equipment and receiver.
- Connect the equipment into an outlet on a circuit different from that to which the receiver is connected.
- Consult the dealer or an experienced radio/TV technician for help. Restriction of the use of certain hazardous substances (RoHS): Meets 2011-65-EU Directive.

Made in China

Limited Warranty, Warranty Exclusions, Limit of Liability and RMA Request Instructions

See the SCS Warranty -

<http://staticcontrol.descoindustries.com/warranty.aspx>