

# MAXIM

## Regulated 3.3V Charge Pump

MAX679

### General Description

The MAX679 step-up, regulated charge pump generates a 3.3V  $\pm$ 4% output voltage from a 1.8V to 3.6V input voltage (two alkaline, NiCd, or NiMH; or one Lithium-Ion battery). Output current is 20mA (min) from a 2.0V input. Only three external capacitors are needed to build a complete DC-DC converter.

The MAX679's switching frequency is pin selectable at 330kHz or 1MHz to allow trade-offs between lowest supply current and smallest-size capacitors. The logic shutdown function reduces the supply current to 5 $\mu$ A (max) and disconnects the load from the input. Special soft-start circuitry prevents excessive current from being drawn from the battery during start-up. This DC-DC converter requires no inductors and has low EMI. It is available in the ultra-small  $\mu$ MAX package, which is only 1.11mm high and half the area of an 8-pin SO.

### Applications

Battery-Powered Applications  
 Miniature Equipment  
 Backup-Battery Boost Converters  
 Translators  
 Two-Way Pagers

### Features

- ◆ Regulated 3.3V  $\pm$ 4% Output
- ◆ Ultra-Small:  
1.1mm-High, 8-Pin  $\mu$ MAX Package
- ◆ No Inductors Required
- ◆ Up to 1MHz Operation  
(small external components)
- ◆ Fits into 0.05 in.<sup>2</sup>
- ◆ Up to 85% Efficiency
- ◆ 1.8V to 3.6V Input Voltage Range
- ◆ 50 $\mu$ A Quiescent Supply Current
- ◆ 1 $\mu$ A Shutdown Current

### Ordering Information

| PART      | TEMP. RANGE    | PIN-PACKAGE |
|-----------|----------------|-------------|
| MAX679C/D | 0°C to +70°C   | Dice*       |
| MAX679EUA | -40°C to +85°C | 8 $\mu$ MAX |

\*Dice are tested at  $T_A = +25^\circ\text{C}$  only.

4

### Typical Operating Circuit

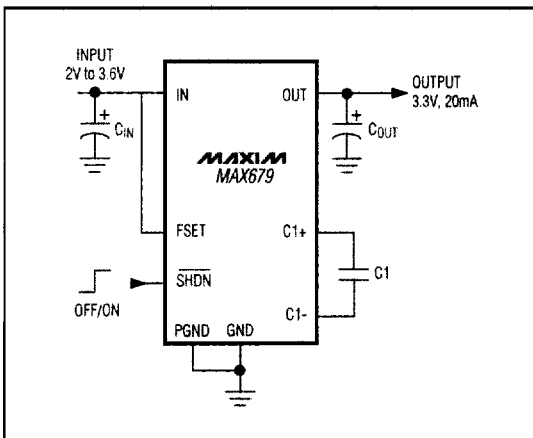

### Pin Configuration

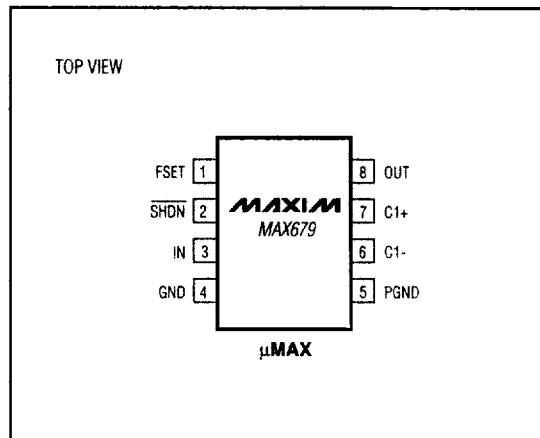

MAXIM

Maxim Integrated Products 4-23

For free samples & the latest literature: <http://www.maxim-ic.com>, or phone 1-800-998-8800  
 For small orders, phone 408-737-7600 ext. 3468.

# Regulated 3.3V Charge Pump

**MAX679**

## ABSOLUTE MAXIMUM RATINGS

|  |   |   |   |
|--|---|---|---|
| IN, OUT, $\overline{\text{SHDN}}$ , FSET to GND..... | -0.3V to 6V                                 | Continuous Power Dissipation ( $T_A = +70^\circ\text{C}$ )                  |   |
| PGND to GND.....                                     | $\pm 0.3\text{V}$                           | $\mu\text{MAX}$ (derate 4.1mW/ $^\circ\text{C}$ above $+70^\circ\text{C}$ ) | 330mW                                       |
| C1- to GND.....                                      | -0.3V to ( $V_{\text{IN}} + 0.3\text{V}$ )  | Operating Temperature Range   | $-40^\circ\text{C}$ to $+85^\circ\text{C}$  |
| C1+ to GND.....                                      | -0.3V to ( $V_{\text{OUT}} + 0.3\text{V}$ ) | Storage Temperature Range   | $-65^\circ\text{C}$ to $+160^\circ\text{C}$ |
| OUT Short to GND.....                                | 10sec                                       | Lead Temperature (soldering, 10sec)   | $+300^\circ\text{C}$                        |

Stresses beyond those listed under "Absolute Maximum Ratings" may cause permanent damage to the device. These are stress ratings only, and functional operation of the device at these or any other conditions beyond those indicated in the operational sections of the specifications is not implied. Exposure to absolute maximum rating conditions for extended periods may affect device reliability.

## ELECTRICAL CHARACTERISTICS

( $V_{\text{IN}} = V_{\overline{\text{SHDN}}} = V_{\text{FSET}} = 2\text{V}$ ,  $C_{\text{IN}} = 4.7\mu\text{F}$ ,  $C_1 = 0.33\mu\text{F}$ ,  $C_{\text{OUT}} = 10\mu\text{F}$ ,  $T_A = -40^\circ\text{C}$  to  $+85^\circ\text{C}$ , unless otherwise noted. Typical values are at  $T_A = +25^\circ\text{C}$ .) (Note 1)

| PARAMETER  | CONDITIONS   |  | MIN                        | TYP                        | MAX                        | UNITS         |
|--|--|--|----------------------------|----------------------------|----------------------------|---------------|
| Input Voltage  |  |  | 1.8                        |                            | 3.6                        | V             |
| Input Undervoltage Lockout Voltage                   |  |  | 0.8                        |                            | 1.6                        | V             |
| Output Voltage                                       | $2\text{V} < V_{\text{IN}} < 3.3\text{V}$ ,<br>$0\text{mA} < I_{\text{OUT}} < 20\text{mA}$ | $T_A = 0^\circ\text{C}$ to $+85^\circ\text{C}$   | 3.17                       | 3.3                        | 3.43                       | V             |
|  |  | $T_A = -40^\circ\text{C}$ to $+85^\circ\text{C}$ | 3.15                       |                            | 3.45                       |               |
| Output Current                                       | $V_{\text{IN}} = 1.8\text{V}$ , $V_{\text{OUT}} > 3.17\text{V}$                            |  |                            | 20                         |                            | mA            |
| No-Load Supply Current                               | $V_{\text{IN}} = 2.5\text{V}$ , FSET = IN or GND   |  |                            | 50                         | 80                         | $\mu\text{A}$ |
| Leakage Current into OUT in Shutdown                 | $V_{\text{OUT}} = 3.6\text{V}$ , $\overline{\text{SHDN}} = \text{GND}$                     |  |                            | 15                         | 25                         | $\mu\text{A}$ |
| Supply Current in Shutdown                           | $V_{\text{IN}} = 3.3\text{V}$  |  |                            | 1                          | 5                          | $\mu\text{A}$ |
| FSET, $\overline{\text{SHDN}}$ Input Voltage Low     | $V_{\text{IN}} = 1.8\text{V}$  |  |                            | $0.5 \times V_{\text{IN}}$ | $0.3 \times V_{\text{IN}}$ | V             |
| FSET, $\overline{\text{SHDN}}$ Input Voltage High    | $V_{\text{IN}} = 3.6\text{V}$  |  | $0.7 \times V_{\text{IN}}$ | $0.5 \times V_{\text{IN}}$ |                            | V             |
| FSET, $\overline{\text{SHDN}}$ Input Leakage Current | FSET, $\overline{\text{SHDN}} = \text{GND}$ or $V_{\text{IN}}$                             |  |                            | 0.1                        | 1                          | $\mu\text{A}$ |
| Switching Frequency                                  | FSET = GND   |  | 260                        | 330                        | 450                        | kHz           |
|  | FSET = IN  |  | 700                        | 1000                       | 1300                       |               |
| Output Short-Circuit Current                         | OUT = GND, $V_{\text{IN}} = 3.3\text{V}$   |  |                            | 100                        | 200                        | mA            |
| Efficiency   | $V_{\text{IN}} = 2\text{V}$ , $I_{\text{OUT}} = 10\text{mA}$                               |  |                            | 80                         |                            | %             |

**Note 1:** Specifications to  $-40^\circ\text{C}$  are guaranteed by design, not production tested.

# Regulated 3.3V Charge Pump

## Typical Operating Characteristics

(Typical Operating Circuit with:  $V_{IN} = V_{SHDN} = 2V$ ,  $C_{IN} = 4.7\mu F$ ,  $C_1 = 0.33\mu F$ ,  $C_{OUT} = 10\mu F$ , tested in-circuit,  $T_A = +25^\circ C$ , unless otherwise noted.)

**MAX679**

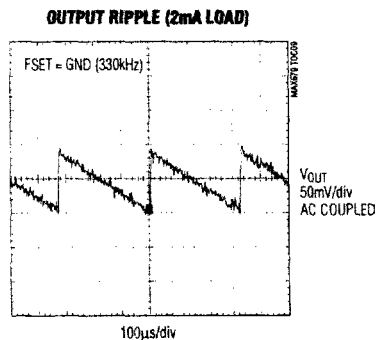
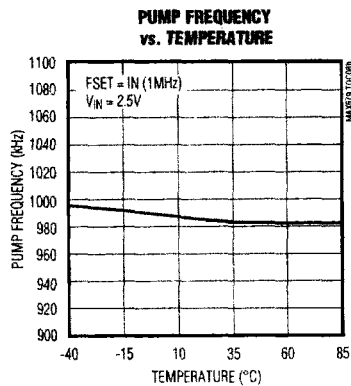
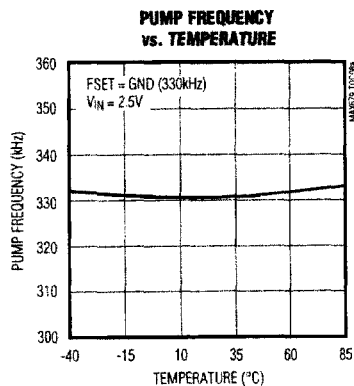
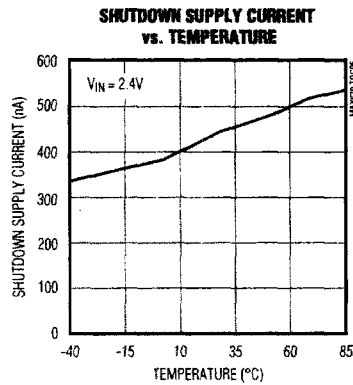
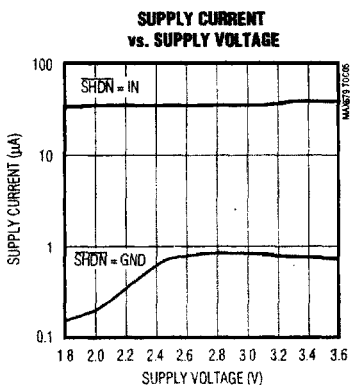
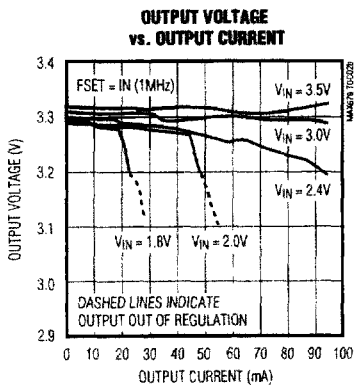
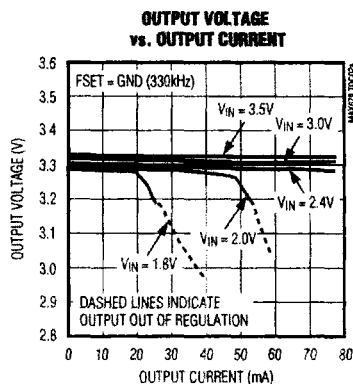
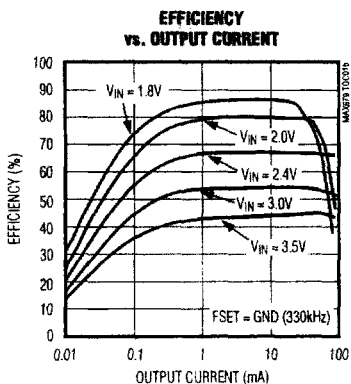
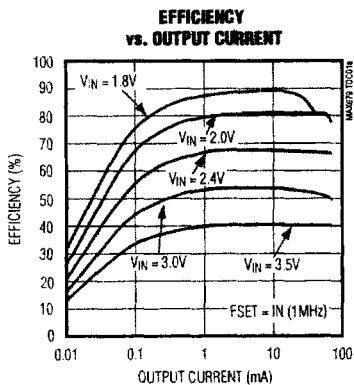

**4**

# Regulated 3.3V Charge Pump

## Typical Operating Characteristics (continued)

(Typical Operating Circuit with:  $V_{IN} = V_{SHDN} = 2V$ ,  $C_{IN} = 4.7\mu F$ ,  $C_1 = 0.33\mu F$ ,  $C_{OUT} = 10\mu F$ , tested in-circuit,  $T_A = +25^\circ C$ , unless otherwise noted.)

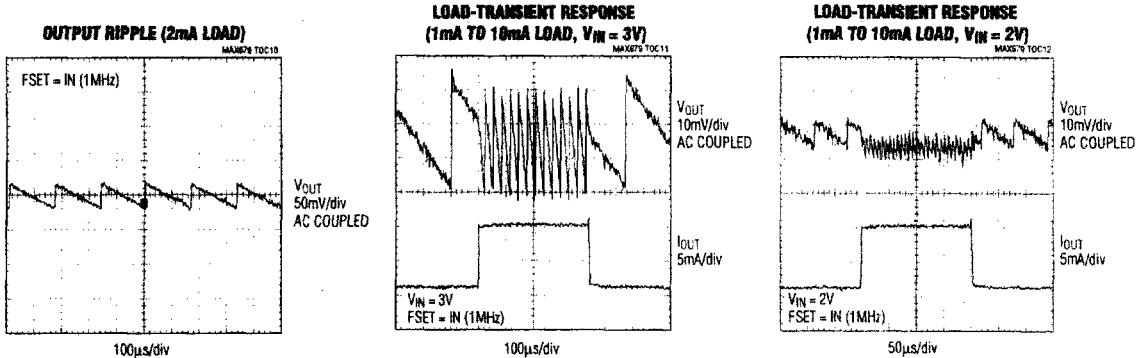

## Pin Description

| PIN | NAME | FUNCTION   |
|-----|------|--|
| 1   | FSET | Set Charge-Pump Frequency Input. FSET = GND selects 330kHz and FSET = IN selects 1MHz. Do not leave FSET unconnected.  |
| 2   | SHDN | Shutdown Input. The device shuts down, the output disconnects from the input, and the supply current decreases to 1μA when SHDN is a logic low. Connect SHDN to IN for normal operation. |
| 3   | IN   | Supply Input. Connect to an input supply in the 1.8V to 3.6V range. Bypass IN to GND with a $(C_{OUT} / 2)\mu F$ capacitor.  |
| 4   | GND  | Ground. Analog ground for internal reference and control circuitry.  |
| 5   | PGND | Power Ground. Charge-pump current flows through this pin.  |
| 6   | C1-  | Negative Terminal of the Charge-Pump Capacitor   |
| 7   | C1+  | Positive Terminal of the Charge-Pump Capacitor   |
| 8   | OUT  | 3.3V Power Output. Bypass OUT to GND with an output filter capacitor (see the Design Procedure section).   |

## Detailed Description

The MAX679 regulated charge pump has a 50% duty-cycle clock. In phase one (charge phase), the charge-transfer capacitor (C1) charges to the input voltage, and output current is delivered by the output filter capacitor (C<sub>OUT</sub>). In phase two (transfer phase), C1 is placed in series with the input and connects to the output, transferring its charge to C<sub>OUT</sub>. If the clock were to run continuously, this process would eventually generate an output voltage equal to two times the input voltage (hence the name "doubler").

The charge pump regulates by gating the oscillator on and off as needed to maintain output regulation. This method has low quiescent current, but to achieve acceptable output ripple, C1 must be significantly lower in value than C<sub>OUT</sub>.

## Start-Up Sequence

The MAX679 soft-start circuitry prevents excessive current from being drawn from the battery at start-up or when the output is shorted. This is done by limiting the charge pump to 1/10 the normal current until either the output is in regulation or the first 4096 charge-pump

# Regulated 3.3V Charge Pump

MAX679

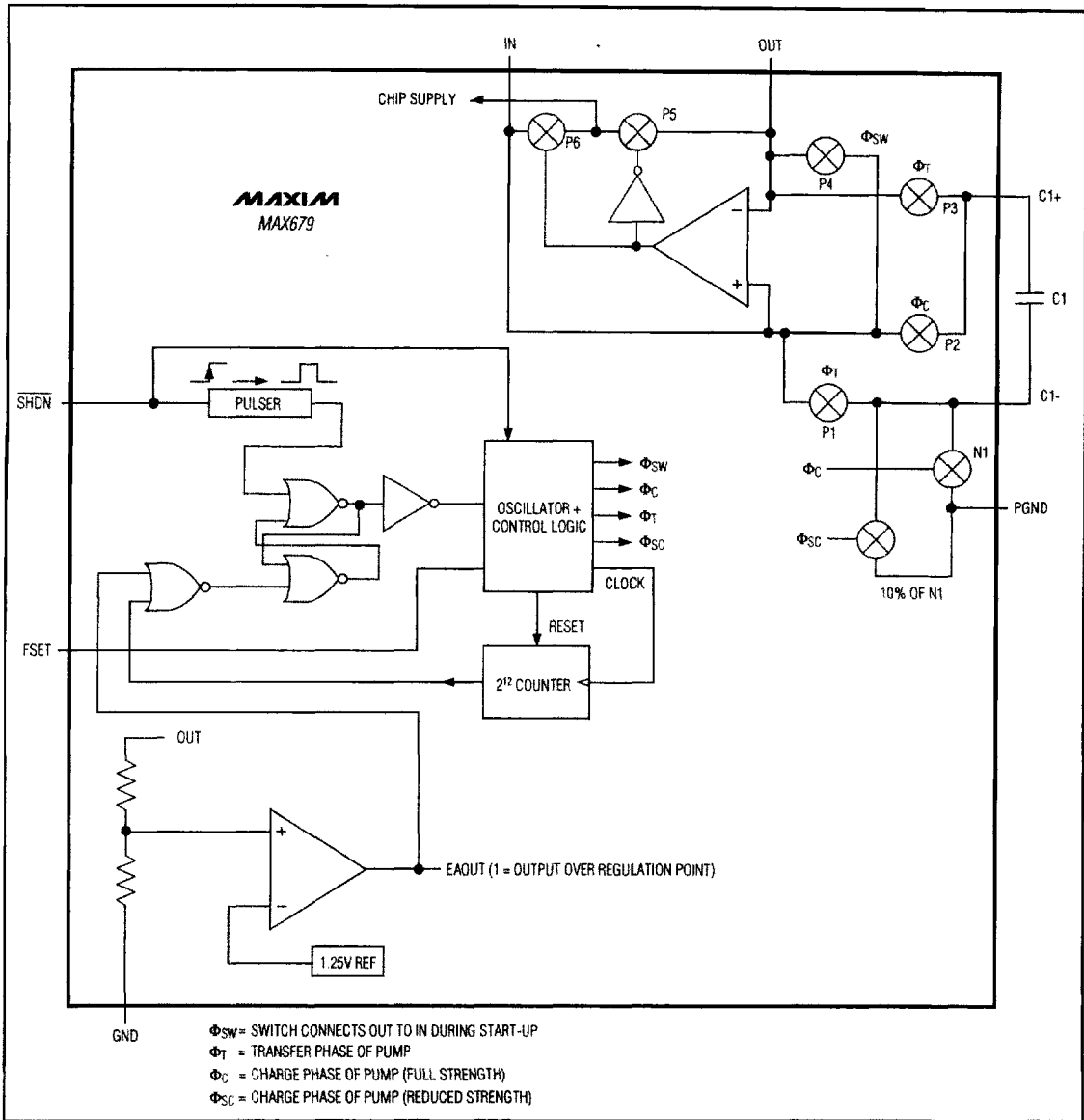

Figure 1. Block Diagram

4

## Regulated 3.3V Charge Pump

cycles (about 4ms) have elapsed. The start-up sequence begins at power-up, when exiting shutdown, or when recovering from a short circuit. If  $V_{IN}$  is less than the 1.6V UVLO threshold, the device remains shut down and ignores a high SHDN input.

### Design Procedure

Optimize the charge-pump circuit for size, quiescent current, and output ripple by properly selecting the operating frequency and capacitors  $C_{IN}$ ,  $C_1$ , and  $C_{OUT}$ .

For lowest output ripple, select 1MHz operation ( $FSET = 1N$ ). In addition, increasing  $C_{OUT}$  relative to  $C_1$  will further reduce ripple. For highest efficiency, select 330kHz operation ( $FSET = GND$ ) and select the largest practical values for  $C_{OUT}$  and  $C_1$  while maintaining a 30-to-1 ratio. See Table 1 for some suggested values and the resulting output ripple.

Note that the capacitors must have low ESR (<20m $\Omega$ ) to maintain low ripple. Currently, only ceramic capacitors can provide such low ESR; therefore, the output filter capacitors should be a combination of a 1 $\mu$ F ceramic capacitor and a 10 $\mu$ F tantalum capacitor.

### Smallest Size

Set the frequency to 1MHz by connecting  $FSET$  to  $1N$ . Table 1 shows typical external component values.

Table 1. External Component Selection

| $V_{IN}$<br>(V) | $C_1$<br>( $\mu$ F) | $C_{OUT}$<br>( $\mu$ F) | $FSET$<br>(Hz) | $V_{p-p}$<br>(mV) |
|-----------------|---------------------|-------------------------|----------------|-------------------|
| 2               | 0.33                | 10                      | 1M             | 7                 |
| 2               | 0.33                | 10                      | 330k           | 14                |
| 2               | 0.1                 | 3.3                     | 1M             | 16                |
| 2               | 0.1                 | 3.3                     | 330k           | 22                |
| 3               | 0.33                | 10                      | 1M             | 27                |
| 3               | 0.33                | 10                      | 330k           | 56                |
| 3               | 0.1                 | 3.3                     | 1M             | 72                |
| 3               | 0.1                 | 3.3                     | 330k           | 89                |

### PC Board Layout

Place  $C_1$ ,  $C_{OUT}$ , and  $C_{IN}$  close to the IC. Connect PGND and GND with a short trace.

### Efficiency

Charge-pump efficiency is best at low frequency (330kHz). The theoretical maximum efficiency is given in the following equation:

$$\text{Theoretical maximum efficiency} = V_{OUT} / (2 \times V_{IN})$$

Gate-charge losses amount to approximately 1mA from the output at full switching frequency (about 5% to 7% loss).

Table 2. Manufacturers of Low-ESR Capacitors

| PRODUCTION METHOD                 | MANUFACTURER | CAPACITORS        | PHONE          | FAX            |
|-----------------------------------|--------------|-------------------|----------------|----------------|
| Surface-Mount Tantalum Capacitors | AVX          | TPS series        | (803) 946-0690 | (803) 626-3123 |
|                                   | Matsuo       | 267 series        | (714) 969-2491 | (714) 960-6492 |
|                                   | Sprague      | 593D, 595D series | (603) 224-1961 | (603) 224-1430 |
| Surface-Mount Ceramic Capacitors  | AVX          | X7R               | (803) 946-0690 | (803) 626-3123 |
|                                   | Matsuo       | X7R               | (714) 969-2491 | (714) 960-6492 |

### Chip Information

TRANSISTOR COUNT: 819

SUBSTRATE CONNECTED TO GND