

REVISIONS					
REV	ECO	DESCRIPTION	DATE	BY	APPR
B1	-	RELEASED DRAWING	JUN-30-2014	BEN	TOMMY
B2	-	VOLTAGE UPDATE AND ADD KEY ICON	Nov-26-20	Ronald	Tommy

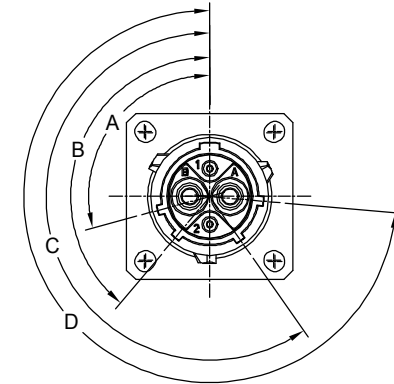

NOTES : (UNLESS OTHERWISE SPECIFIED)

- MATERIAL :
 - SHELL : ZINC ALLOY , NICKEL PLATED.
 - INSERT : THERMOPLASTIC , UL94 V-0.
 - END CAP : THERMOPLASTIC , UL94 V-0.
 - PLASTIC BUSHING : THERMOPLASTIC , UL94 V-0.
 - SEAL GASKET : NBR/SILICONE RUBBER.
 - O-RING : NBR/SILICONE RUBBER.
 - WIRE SEAL : SILICONE RUBBER.
- SPECIFICATIONS :
 - RATED CURRENT :
 - 2.5mm CONTACT 23A (MAX) .
 - 20# CONTACT 5A (MAX).
 - RATED VOLTAGE : 500V (AC/DC) .
 - OPERATING TEMPERATURE : SEE CHART.
 - DIELECTRIC WITHSTANDING VOLTAGE : LESS THAN 2 MILLIAMPS CURRENT LEAKAGE@2000 VOLTS AC.
 - INSULATION RESISTANCE : 5000 MEGOHMS MIN.
 - IP--CLASS : IP67 (MATED CONDITION).
 - MATING CYCLES DURABILITY : 500 CYCLES MIN.
 - ROHS COMPLIANT.
- SUITABLE CONTACTS : 2.5mm & 20# CONTACTS.
- ALL DIMENSIONS ARE FOR REFERENCE USE ONLY.
- CONTACT SIZE AND REAR SEAL WIRE RANGE :

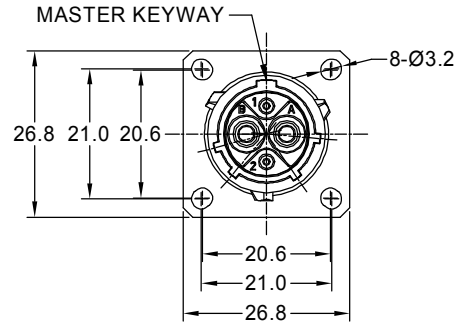
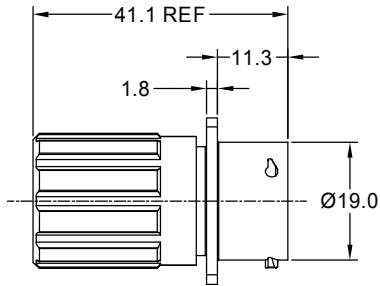
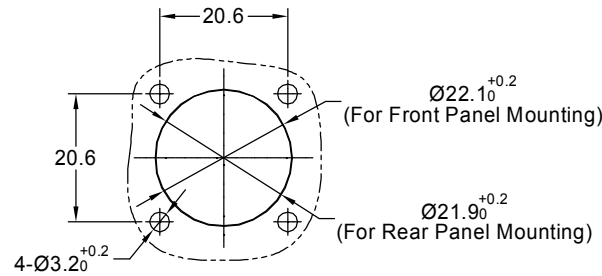

PANEL CUT OUT REFERENCE

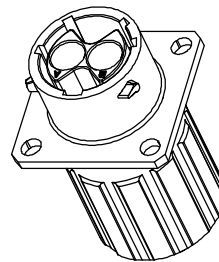

KEY POS	PART NUMBER					
	-40°C ~ 105°C	-40°C ~ 125°C	A	B	C	D
N	RT00122PNHEC	RT00122PNHEC03	105°	140°	215°	265°
W	RT00122PWHEC	RT00122PWHEC03	60°	140°	215°	265°
X	RT00122PXHEC	RT00122PXHEC03	105°	155°	215°	265°
Y	RT00122PYHEC	RT00122PYHEC03	105°	140°	225°	265°
Z	RT00122PZHEC	RT00122PZHEC03	105°	140°	215°	295°

QUANTITY	SEE PART NUMBER CHART	PART NUMBER	DESCRIPTION	ITEM
MATERIALS LIST				
UNLESS OTHERWISE SPECIFIED		SIGNATURES	DATE	<p>Sine Systems - www.amphenol-sine.com 44724 Morley Drive Clinton Township, MI 48036</p>
1) All dimensions are in metric(mm).		DRAWN: Ronald	Nov-26-20	
2) Tolerances are as follows:		CHECKED: Ron	Nov-27-20	
1 PL DEC ±0.30 2 PL DEC ±0.15 3 PL DEC ±0.08		ENGINEER:		
3) Note reference =		APPROVAL: Tommy	Nov-28-20	
MATERIAL SPECIFICATIONS:		CUSTOMER:		
PROCESS SPECIFICATIONS:		THIS DRAWING IS SUPPLIED FOR INFORMATION ONLY. DESIGN FEATURES, SPECIFICATIONS AND PERFORMANCE DATA SHOWN HEREON ARE THE PROPERTY OF THE AMPHENOL CORPORATION. NO RIGHTS OF REPRODUCTION ARE IMPLIED. ALL DIMENSIONS ARE SUBJECT TO NORMAL MANUFACTURING VARIATIONS.		
NEXT ASSY:		SCALE: NONE		
			SIZE: B TYPE: C- DWG NO: RT00122P*HEC	REVISION: B2
			SHEET 1 OF 1	

CONTACT SIZE	MIN. INSUL O.D.	MAX. INSUL O.D.	WIRE RANGE
2.5mm	Ø3.3mm	Ø4.3mm	14 - 12AWG
20#	Ø1.6mm	Ø2.6mm	30 - 20AWG

TITLE: ECOMATE RM,RECEPTACLE, SIZE 12,2POS,PIN,END CAP. DWG NO: RT00122P*HEC. REV: B2. SH: 1 OF: 1