

HAP02 SERIES

POWER RELAY



File No.:E75887



File No.:R 50461488



FEATURES

- 2 Form A and 2 Form C configurations
- Low height, only 15.7mm
- Creepage/clearance distance > 10mm,
- Meets reinforce insulation
- 5KVAC dielectric strength (between coil and contacts)

CONTACT RATINGS

Contact Arrangement	2A, 2C
Contact Resistance	≤100mΩ (1A 6VDC)
Contact Material	AgSnO
Contact Rating	16A/277VAC
Max. Switching Voltage	277VAC
Max. Switching Current	16A
Max. Switching Power	4432VA
Mechanical Life	5×10 ⁶ operations
Electrical Life	1×10 ⁵ operations (2NO:16A/277VAC, Resistive load 85°C, 1s on 9s off)

ORDERING INFORMATION

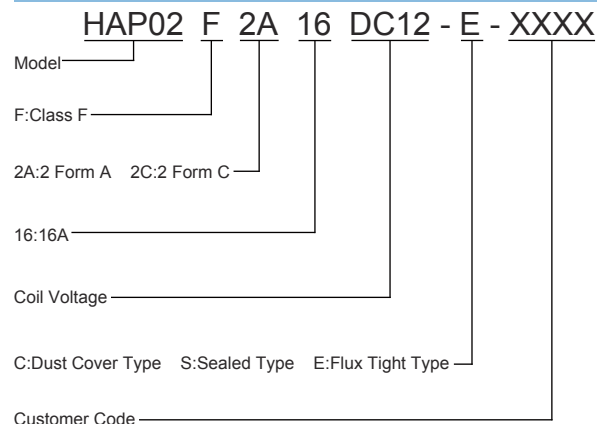

Notes:

1. PC board assembled with dust cover type and flux tight type relays can not be washed and/or coated.
2. Dust cover type and flux tight type relays can not be used in the environment with dust, or H₂S, SO₂, NO₂ or similar gaseous environment etc.

CHARACTERISTICS

Insulation Resistance	1000MΩ (at 500VDC)	
Dielectric Strength	Between coil & contacts	5000VAC 1min
	Between open contacts	1000VAC 1min
	Between contacts sets	2500VAC 1min
Surge Voltage(Between coil & contacts)	10kVAC(1.2/50μs)	
Operate time (at nomi. volt.)	≤10ms	
Release time (at nomi. volt.)	≤5ms	
Humidity	5% to 85% RH	
Operation temperature	-40°C~+105°C	
Class F	Insulation System Class F	
Shock Resistance	Operating extremes	98m/s ²
	Damage limits	980m/s ²
Vibration resistance	10Hz ~ 50Hz 1.0mm DA	
Unit weight	Approx. 16.5g	
Construction	Sealed Type, Dust Cover Type, Flux Tight Type	

Notes: The data shown above are initial values.

This datasheet is for customers' reference. All the specifications are subject to change without notice.

COIL DATA

at 25°C

Nominal Voltage VDC	Operate Voltage (Max.) VDC	Release Voltage (Min.) VDC	*Max. Allowable Voltage VDC	Coil Resistance Ω±10%
5	3.5	0.50	7.5	31.3
6	4.2	0.60	9.0	45.0
9	6.3	0.90	13.5	101.3
12	8.4	1.20	18.0	180
24	16.8	2.40	36.0	720
48	33.6	4.80	72.0	2880

Note:

*"Max Allowable Voltage": The relay coil can endure max allowable voltage for a short period time only.

COIL

Coil Power	Approx. 800mW
------------	---------------



* SINCE 1976 *

TEL:(516) 328-9292 FAX:(516)326-9125 www.hascorelays.com email:info@hascorelays.com

RELAYS

HAP02 SERIES

POWER RELAY

SAFETY APPROVAL RATINGS

UL & CUL & CQC	N.O.:16A/277VAC, Resistive, 5×10^4 OPS, 85°C
	N.O.:5A 120VAC, E. Ballast, 6×10^3 OPS, 40°C
	N.O.:1HP 240VAC, Horse Power, 6×10^3 OPS, 40°C
	N.O.:TV-8 120VAC, 2.5×10^4 OPS, 50°C
	N.C.:16A/277VAC, Resistive, 2×10^4 OPS, 85°C
	N.O./N.C.:16A/277VAC, Resistive, 6×10^3 OPS, 85°C

TüV	N.O.:16A/277VAC, Resistive, 1×10^5 OPS, 85°C
	N.O.:16A/277VAC, Resistive, 5×10^4 OPS, 105°C
	N.C.:16A/277VAC, Resistive, 5×10^4 OPS, 85°C
	N.O./N.C.:16A/277VAC, Resistive, 2×10^4 OPS, 85°C

NOTES:

1. All values without specified temperature are at 25°C.
2. The above lists the typical loads only. Other loads may be available upon request.

OUTLINE DIMENSIONS, WIRING DIAGRAM AND PC BOARD LAYOUT.

Unit: inch(mm)

Outline Dimensions

Wiring Diagram
(Bottom view)

PCB Layout
(Bottom view)

<p>Unless otherwise specified tolerances are:</p> <table border="1"> <tr> <td>≤1mm</td> <td>>1mm and ≤5mm</td> <td>>5mm</td> </tr> <tr> <td>±0.2mm</td> <td>±0.3mm</td> <td>±0.4mm</td> </tr> </table>			≤1mm	>1mm and ≤5mm	>5mm	±0.2mm	±0.3mm	±0.4mm	<p>* The tolerance without indicating for PCB layout is always ±0.1mm.</p>
≤1mm	>1mm and ≤5mm	>5mm							
±0.2mm	±0.3mm	±0.4mm							

This datasheet is for customers' reference. All the specifications are subject to change without notice.



RELAYS

* SINCE 1976 *

TEL:(516) 328-9292 FAX:(516)326-9125 www.hascorelays.com email:info@hascorelays.com

PACKAGING SPECIFICATION

BLISTER BOX	INNER CARTON	OUTER CARTON	OUTER CARTON SIZE
25PCS	650PCS	1300PCS	L580mm*W400mm*H175mm

APPLICATION GUIDELINES

Automatic Soldering

- * Flow solder is the optimum method for soldering.
- * Adjust the level of solder so that it does not overflow onto the top of the PC board.
- * Unless otherwise specified, solder under the following conditions depending on the type of relay.

Preheat time 20°C-100°C	Rising slope 20°C-120°C	Decreasing slope Peak-150°C	Welding temperature 255°C-265°C
90±5 seconds	< 3°C/s	< 4°C/s	3~5s

Hand Soldering

- * Keep the tip of the soldering iron clean.

Solder Iron	30W or 60W
Iron Tip Temperature	Approx. 350°C 662°F
Solder Time	Within approx. 3 seconds

- * Immediate air cooling is recommended to prevent deterioration of the relay and surrounding parts due to soldering heat.
- * Although the sealed type relay can be cleaned, avoid immersing the relay into cold liquid (such as washing solvent) immediately after soldering. Doing so may deteriorate the sealing performance.

Discard the dropped product

This datasheet is for customers' reference. All the specifications are subject to change without notice.