

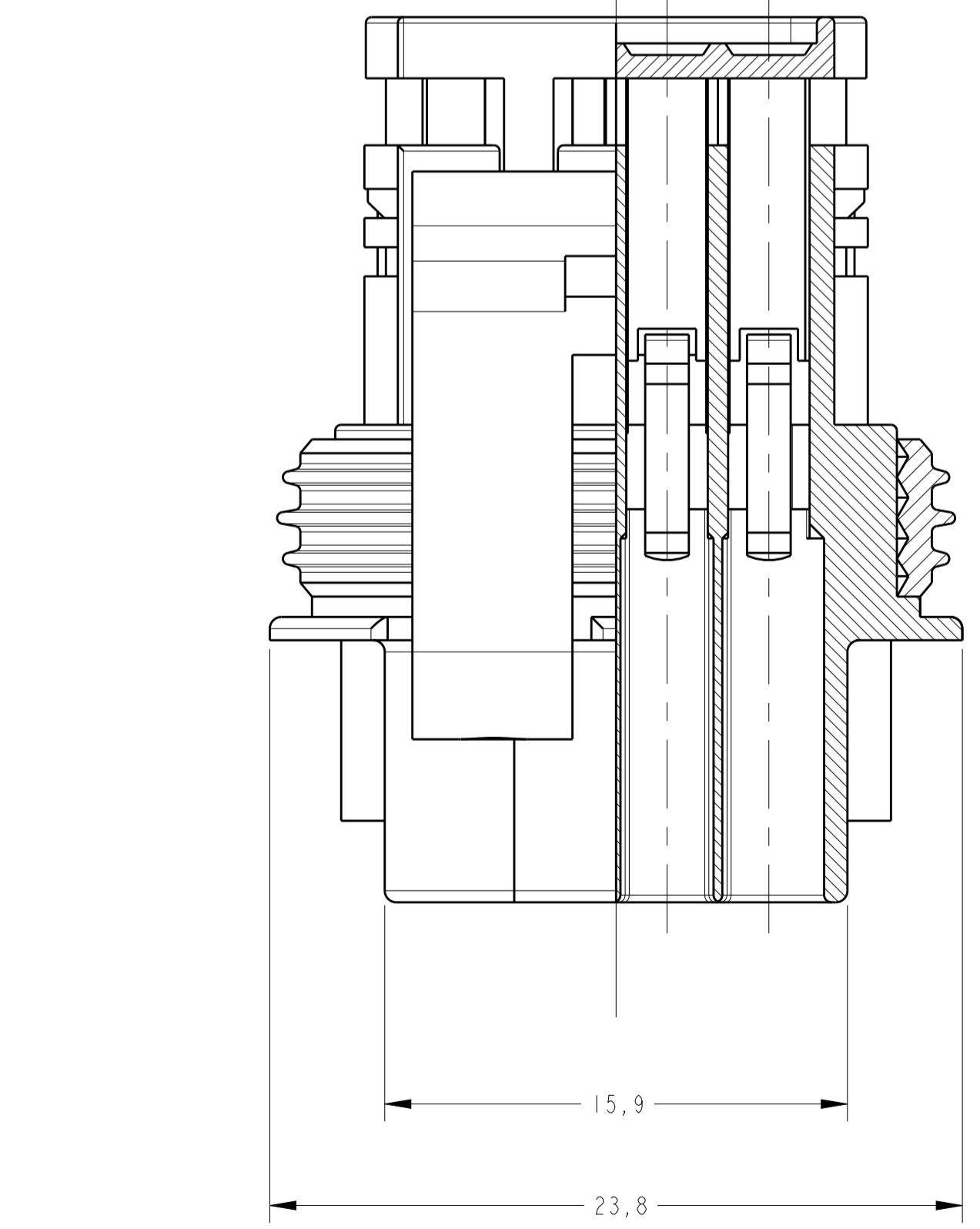

REVISIONS				
P.	LTN.	DESCRIPTION	DATE	DMN. APVD.
R4		REVISED DESIGN ECO-12-011787	27JUN2012	NCL MCM
R5		ADDED PRODUCT SPEC. ECO-15-001585	12FEB2015	NCL MLO

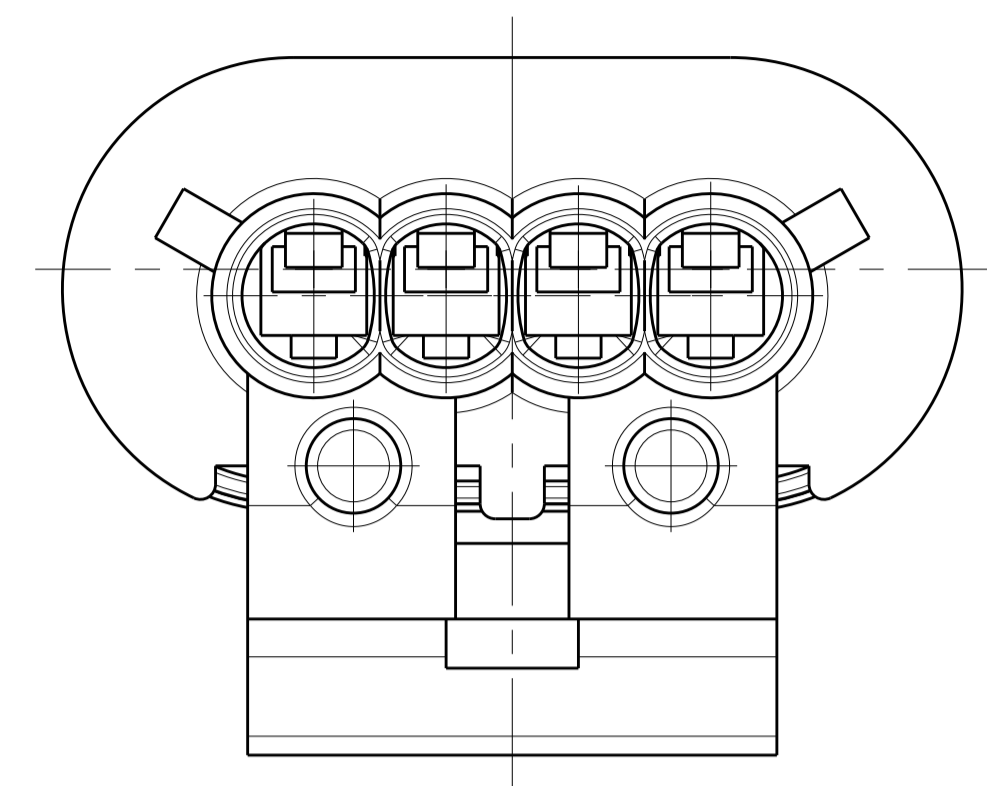
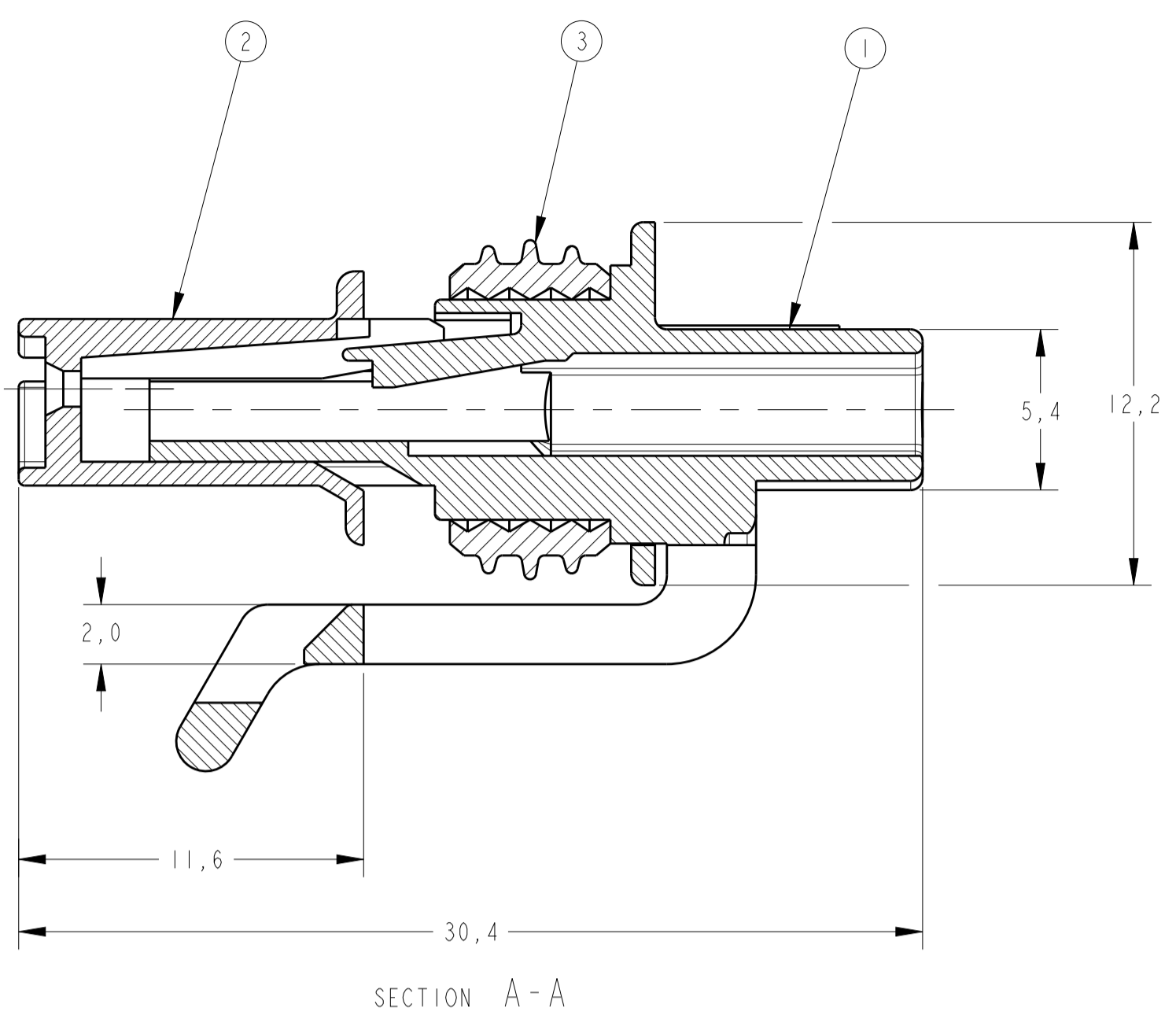
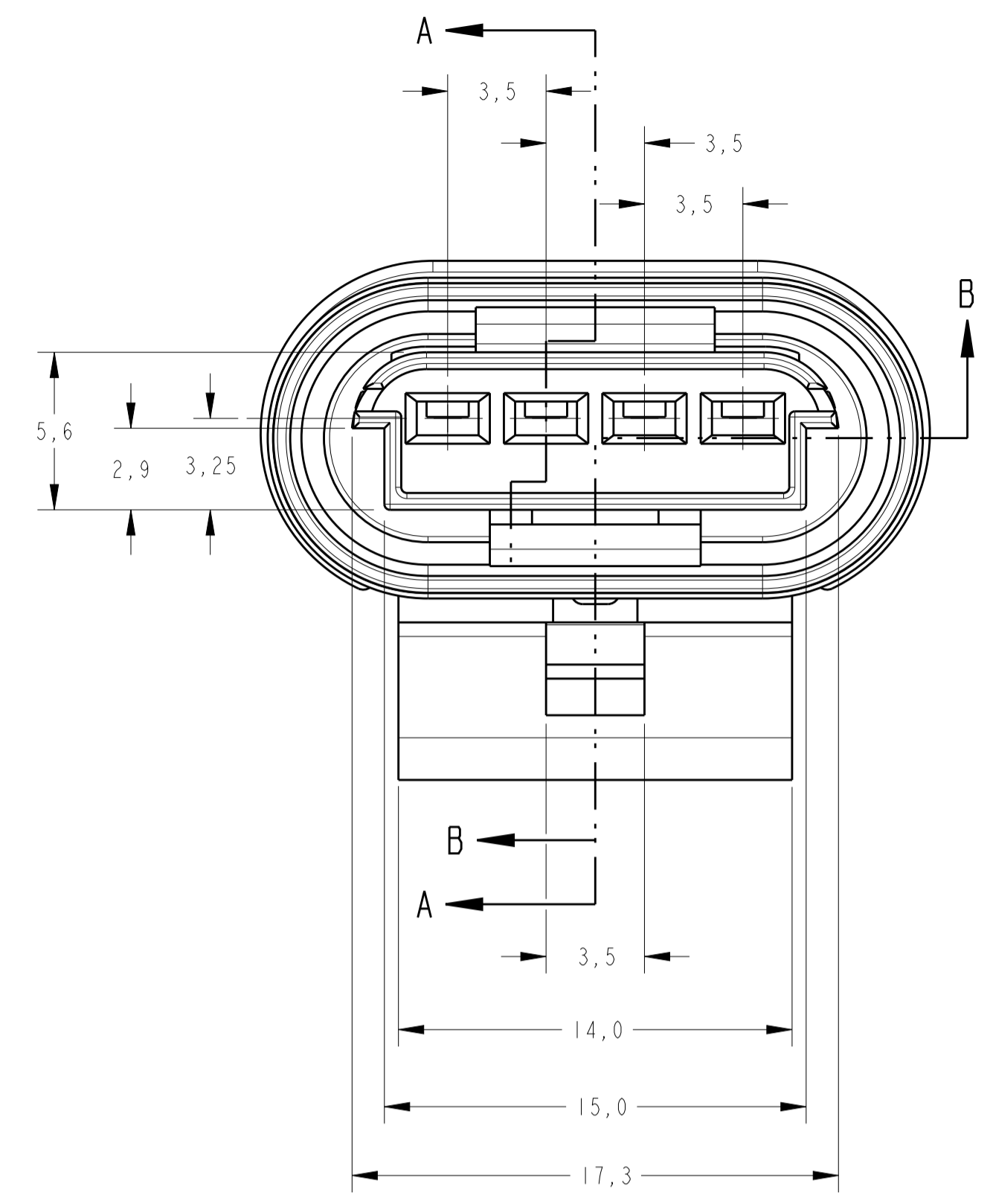

**INFORMAÇÕES DA CONTRA-PEÇA COMO MOSTRADO PARA PN. 444046-1**  
 MATING CONNECTOR INFORMATION AS SHOWN FOR PN. 444046-1  
 SCALE 2:1

FROM  $\phi$  OF SEALING AREA (9.80) TO  $\phi$  OF TERMINAL TAB

SEE DETAIL A

PONTA DO TERMINAL DEVE ESTAR LIVRE DE REBARBAS  
 TERMINAL MUST BE FREE OF BURRS.

SECTION A-A

DETAIL A  
 SCALE 4:1

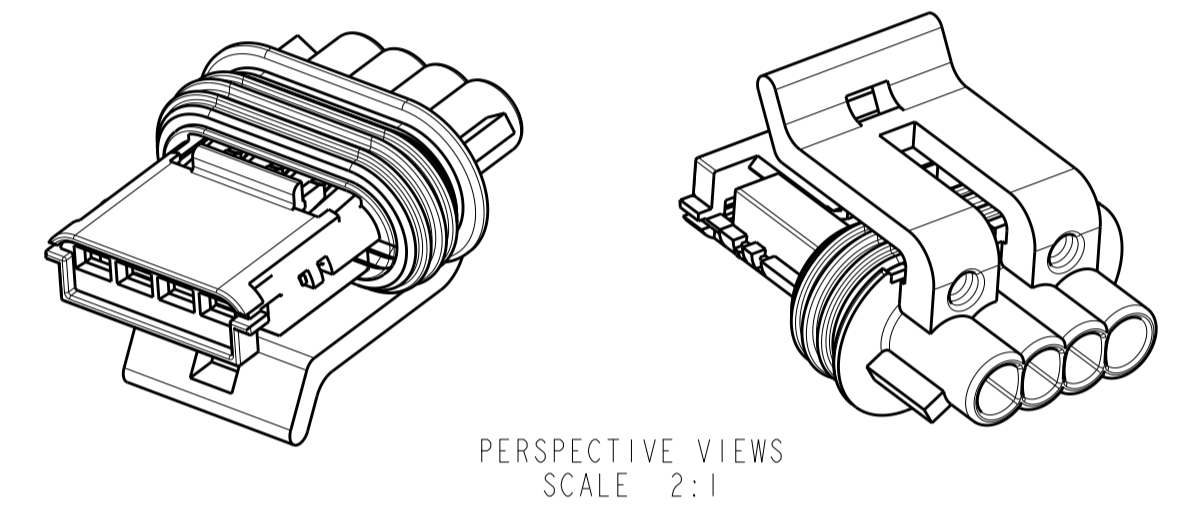

ESPESSURA DE PAREDE WALL THICK

1,4 MIN. ESPESSURA DE PAREDE WALL THICK

A SUPERFÍCIE DE VEDAÇÃO DEVE SER POLIDA, LIVRE DE REBARBAS E DEFORMAÇÕES. RUGOSIDADE NA FERRAMENTA  $Ra < 0,3 \mu m$ . ÂNGULO DE SAÍDA PERMITIDO -  $0,5^\circ$  MAX.

SEALING SURFACE MUST BE POLISHED, AND FREE FROM FLASH OR DEFORMATION. MOULD SURFACE ROUGHNESS ON TOOLING CORE  $Ra < 0,3 \mu m$ .  $0,5^\circ$  MAX. - DRAFT ANGLE PERMITTED.

ÂNGULO DE SAÍDA PERMITIDO -  $1^\circ$  MAX.  $1^\circ$  MAX. - DRAFT ANGLE PERMITTED.

SECTION B-B

PERSPECTIVE VIEW SCALE 1:1

2 - DETALHE DO DIMENSIONAMENTO DA TRAVA  
 DETAIL DESIGN OF THE LOCK

PERSPECTIVE VIEW SCALE 1:1

3 - DETALHE DO DIMENSIONAMENTO DA TRAVA  
 DETAIL DESIGN OF THE LOCK

- 1 - DIMENSIONADO NO TOPO DO ELEMENTO. DIMENSIONING AT THE TOP OF ELEMENT.
- 2 - INFORMAÇÕES DA CONTRA PEÇA PARA PN. 444046-1; 444046-2; 444046-3 MATING CONNECTOR INFORMATION FOR PN. 444046-1; 444046-2; 444046-3
- 3 - INFORMAÇÕES DA CONTRA PEÇA PN. 444046-4 MATING CONNECTOR INFORMATION FOR PN. 444046-4

GRAVAÇÃO MARKING	
LOGOTIPO TYCO	TYCO LOGO
CÓDIGO DO PAÍS PRODUTOR	MANUFACTURER COUNTRY CODE
NÚMERO DA PEÇA DE CONNECTIVITY	TE CONNECTIVITY PART NUMBER
NÚMERO DA CAVIDADE	CAVITY NUMBER
IDENTIFICAÇÃO DO CIRCUITO	CIRCUIT IDENTIFICATION

QTY	DESCRIPTION	MATERIAL	FINISH
1	CONNECTOR SEAL, 4 POSN.	SILICONE	VERDE / GREEN
1	SPACER 4 POSN., MULTI-LOCK RECEP.	PA 6.6	VIOLETA / VIOLET
1	CONNECTOR SEAL, 4 POSN.	SILICONE	LARANJA / ORANGE
1	SPACER 4 POSN., MULTI-LOCK RECEP.	PA 6.6 10%GF	AMARELO / YELLOW
1	SPACER 4 POSN., MULTI-LOCK RECEP.	PA 6.6	AMARELO / YELLOW
1	HOUSING 4 POSN., MULTI-LOCK RECEP.	PA 6.6	PRETO / BLACK

THIS DRAWING IS A CONTROLLED DOCUMENT.		DMN. A. PERUSSI 27JUN2001
DIMENSIONS: mm		CHK. P. L. FARIA 28JUN2001
TOLERANCES UNLESS OTHERWISE SPECIFIED:		APVD. J. M. M. NETO 28JUN2001
0 PLC	±	PRODUCT SPEC
1 PLC	±0.3	APPLICATION SPEC
2 PLC	±0.15	
3 PLC	±	
4 PLC	±	
ANGLES	±	
FINISH	±	

NAME	SIZE	CAGE CODE	DRAWING NO.	RESTRICTED TO
HOUSING ASS'Y, 4 POSN. MULTI-LOCK RECEP.	A1	00779	444046	

CUSTOMER DRAWING SCALE 5:1 SHEET 1 OF 1 REV R5