

REV.	DATE	ECR NO.	DESCRIPTION
A	02/28/02	XXXXXX	MODIFY CONTACT PIN AND BODY LENGTH
B	04/04/03	XXXXXX	UPDATE DRAWING FORMAT
C	08/05/11	2210	CHANGE THE MATERIAL OF SHELL TO ZINC DIECAST

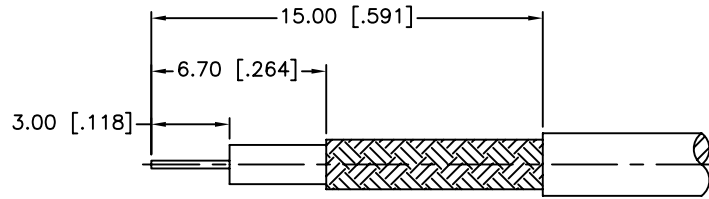

RECOMMENDED
CABLE STRIPPING DIM'S

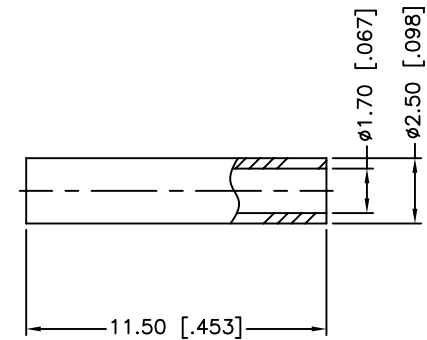
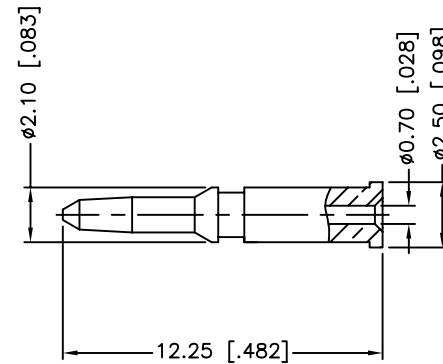
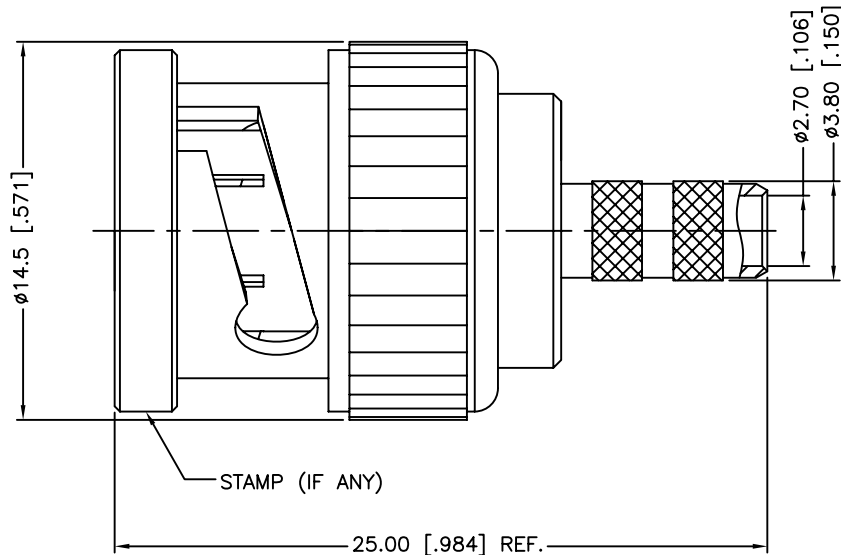
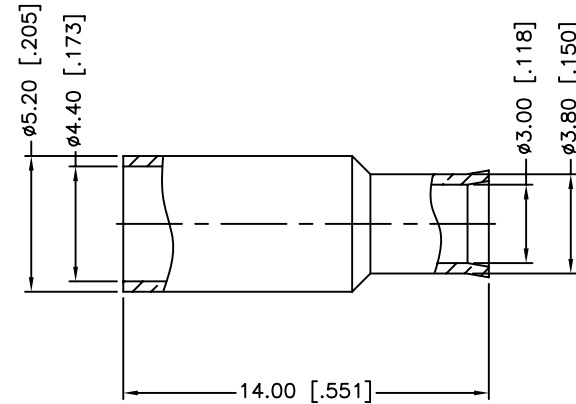

1. CRIMPED FERRULE
HEX CRIMP SIZE .178"
2. CRIMPED CONTACT PIN
HEX CRIMP SIZE .068"

DESCRIPTION	MATERIAL	FINISH	QTY
6 FERRULE	BRASS	NICKEL	1
5 SLEEVE	DELTRIN	NATURAL	1
4 CONTACT PIN	BRASS	GOLD	1
3 INSULATOR	DELTRIN	NATURAL	1
2 BODY	BRASS	NICKEL	1
1 SHELL	ZINC DIECAST	NICKEL	1

UNLESS OTHERWISE SPECIFIED DIMENSIONS ARE IN MILLIMETERS. DIMENSIONS IN [] ARE IN INCHES AND FOR CUSTOMER REFERENCE ONLY.

UNLESS OTHERWISE SPECIFIED TOLERANCES FOR MILLIMETERS ARE:
0.5 - 8mm ± 0.20mm
8 - 30mm ± 0.40mm
30 - 120mm ± 0.50mm

UNLESS OTHERWISE SPECIFIED TOLERANCES FOR INCHES ARE:
.020 - .315 = ± 0.007"
.315 - 1.180 = ± 0.015"
1.180 - 4.724 = ± 0.020"

DO NOT SCALE DRAWING

APPROVALS	DATE
DRAWN M.ZHANG	11/21/06
CHECKED	
ISSUED	
SHEET 1 OF 1	
CAD FILE	C:/CONNEX/112134.DWG

Amphenol Connex

PART DESCRIPTION
**BNC CRIMP PLUG - 50 Ohms
(FOR RG-174/U 188/U, 316/U CABLE)**

PART NO. **112134**

DWG. NO. 112134.DWG	REV. C	SIZE A	SCALE NA
---------------------	--------	--------	----------