

PRODUCT NO. *95706-XXX	STAND OFF DIM "M" (mm)	SOLDER TAIL	DIM "P" (mm)	SHEET NO.	MOUNTING STYLE TO PCB
000	0	R/A	2.8	NO.2	TOP MOUNT 95706-0XX BLACK COLOR
000LF	0	R/A	2.8		
001	0	SMT STAGGERED	--/--		
002	0	SMT IN LINE	--/--		
010	4	R/A	2.8	NO.3	
020	5	R/A	2.8		
040	2	R/A	2.5		
010LF	4	R/A	2.8		
020LF	5	R/A	2.8		
040LF	2	R/A	2.5		
500	0	R/A	2.8	NO.4	BOTTOM MOUNT 95706-5XX
500LF	0	R/A	2.8		
501	0	SMT STAGGERED	--/--		
502	0	SMT IN LINE	--/--		
510	4	R/A	2.8	NO.5	
520	5	R/A	2.8		
540	2	R/A	2.5		
510LF	4	R/A	2.8		
520LF	5	R/A	2.8		
540LF	2	R/A	2.5		

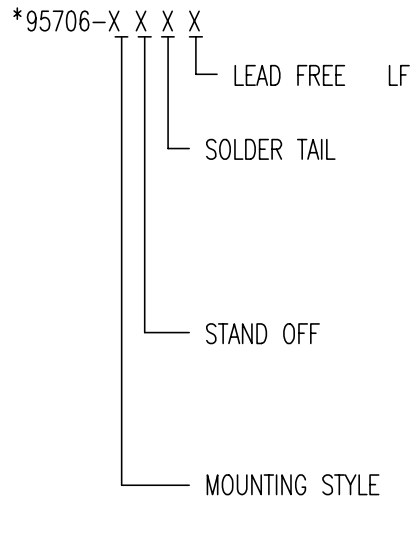

- 0 : R/A (FOR LOWER & SINGLE)
- 1 : SMT STAGGERED (FOR LOWER ONLY)
- 2 : SMT IN LINE (FOR LOWER ONLY)
- 5 : R/A (FOR UPPER ONLY)
- 0 : 0mm
- 1 : 4mm
- 2 : 5mm
- 4 : 2mm
- 0 : TOP MOUNTING
- 5 : BOTTOM MOUNTING

mat'l. code		surface / tolerance		projection		product family	
		ISO1302 ✓ ISO1101 ISO406				MCS	
ltr ecn nodr		date		tolerances unless otherwise specified		title	
B V00619 RGD		3/30/00		0.X±0.3		68 POS. EJECTOR HEADER ASSY.	
C N05-0048 WB		05/29/03		0.XX±0.13		FOR LOW VOLTAGE	
D BX-N-011445 ZK		04/02/12		0.XXX±0.051		scale 1:1	
		dr S.DUESTERHOEFT		7/20/95		dwg no sheet 1 of 5 size	
		enr D.BRANN		7/20/95		95706 A4	
		chr D.BRANN		7/20/95		type Product Customer Drawing	
		appd D.BRANN		7/20/95			
sheet index	revision sheet	D 1	D 2	D 3	D 4	D 5	



PRODUCT NO.
95706-000/000LF
95706-001
95706-002

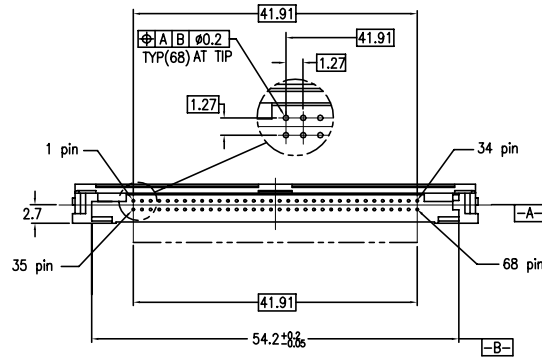
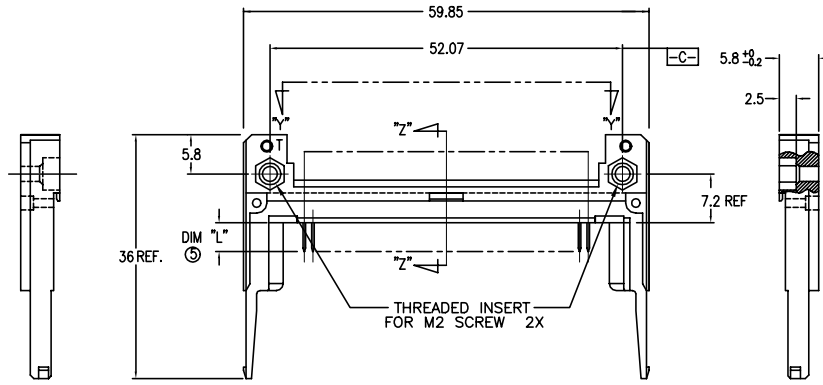

NOTES

- ① TRUE POSITION IS A FREE GRID TO PIN PATTERN ITSELF
- ② SEE TA-946 FOR PCB LAYOUT
- ③ MATERIAL
HOUSING : HIGH TEMPERATURE THERMOPLASTIC UL94V-0 BLACK
PIN : PHOSPHOR BRONZE
- ④ FINISH
PIN
UNDER PLATING : 0.5µm MIN. Ni
CONTACT AREA : 0.076 µm MIN. GOLD

SOLDER AREA(TIN LEAD OPTION): 2.5µm MIN. Sn-Pb
SOLDER AREA(LEAD FREE OPTION): 2.5µm MIN. PURE TIN
- ⑤ SEQUENCE PIN ASSIGNMENT

PIN No.	DIM "L"		
	4.25±0.1	3.5±0.1	5.0±0.1
OTHERS	36.67	1.1734	35.5188

- 6 GENERAL TOLERANCE : ±0.3
- 7 IF LEAD FREE P/N. THE HOUSING WILL WITHSTAND EXPOSURE TO 260°C PEAK TEMPERATURE
SOLDER TAIL : SMT-IL, SMT-STG CAN RESIST 40 SECONDS IN A CONVECTION, INFRA-RED OR VAPOR PHASE REFLOW OVEN.
SOLDER TAIL : R/A CAN RESIST 10 SECONDS IN A WAVE SOLDER APPLICATION WITH A 1.00MM MINIMUM THICK CIRCUIT BOARD.
- 8 IF LEAD FREE P/N PACKAGING MEETS GS-14-920 SPECIFICATION
- 9 PRODUCT SPEC:110-263

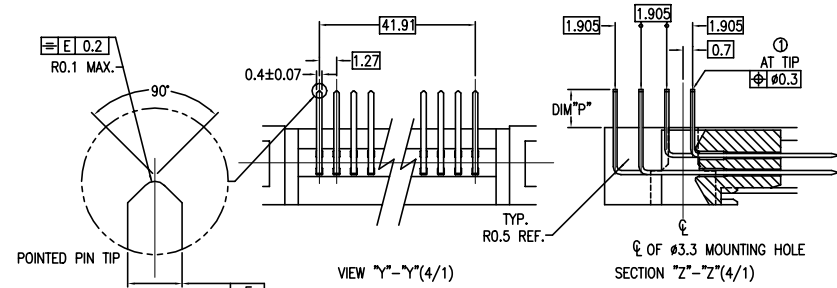

R/A (95706-000/000LF)

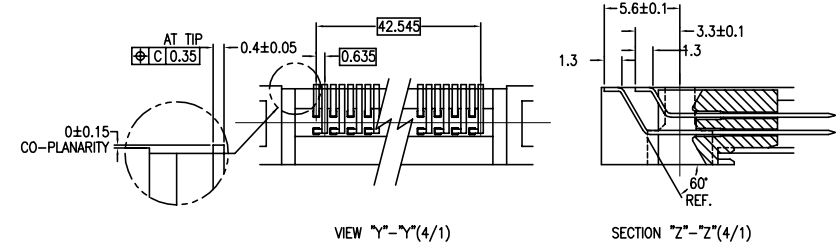

SMT STAGGERED (95706-001)

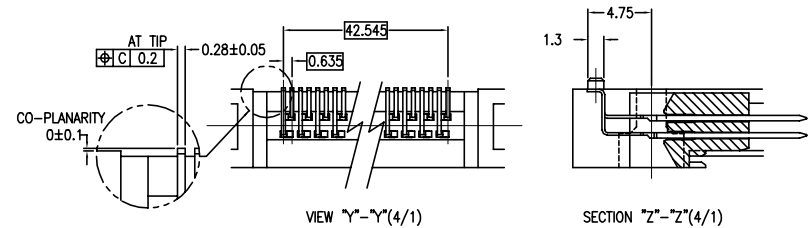

SMT IN LINE (95706-002)

mat'l. code	surface ISO1302 ✓	tolerance ISO1101 ISO406	projection MM	product family MCS
l'tecn nodr	date	tolerances unless otherw	wise specified	title
D		angle 0°±2'	scale 1:1	68 POS. EJECTOR HEADER ASSY. FOR LOW VOLTAGE
		dr S.DUESTERHOEFT 7/20/95		dwg no
		enr D.BRANN 7/20/95		sheet 2 of 5
		chr D.BRANN 7/20/95		size A4
		appd D.BRANN 7/20/95		type Product Customer Drawing
sheet index	revision sheet			

PRODUCT NO.
95706-010/010LF
95706-020/020LF
95706-040/040LF

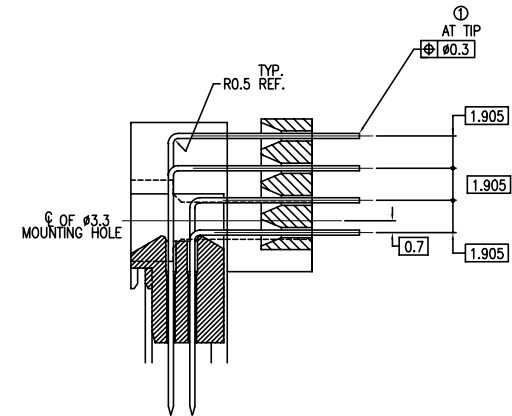
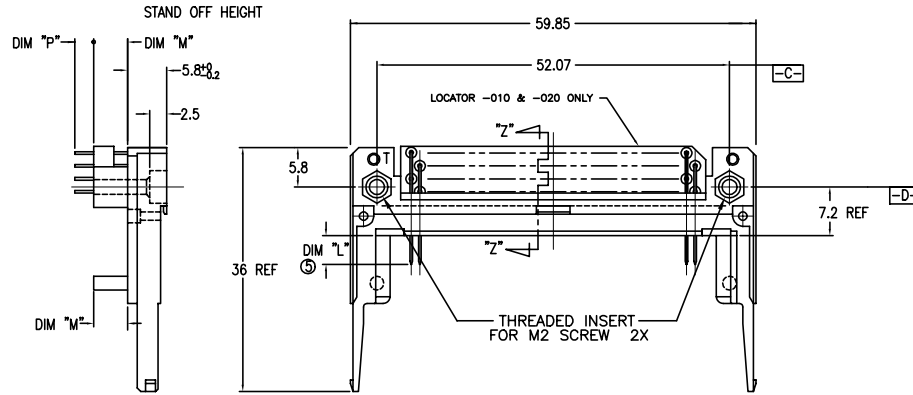

SECTION "Z"- "Z" (5/1)

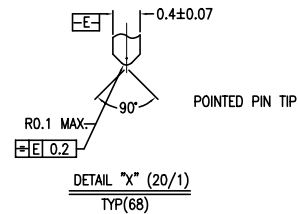
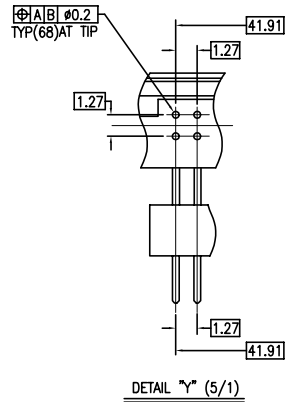
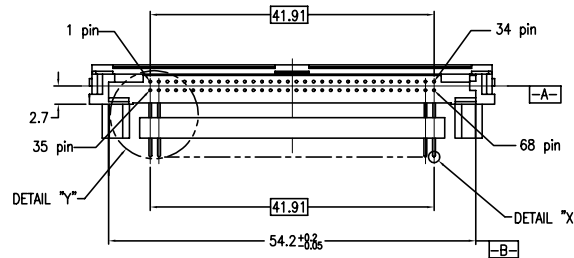

NOTES

- TRUE POSITION IS A FREE GRID TO PIN PATTERN ITSELF.
 - SEE TA-946 FOR PCB LAYOUT.
 - MATERIAL
HOUSING : HIGH TEMPERATURE THERMOPLASTIC UL94V-0 BLACK
PIN : PHOSPHOR BRONZE.
 - FINISH
PIN
UNDER PLATING : 0.5 μ m MIN. Ni.
CONTACT AREA : 0.076 μ m MIN. GOLD

SOLDER AREA(TIN LEAD OPTION): 2.5 μ m MIN. Sn-Pb
SOLDER AREA(LEAD FREE OPTION): 2.5 μ m MIN. PURE TIN
 - SEQUENCE PIN ASSIGNMENT
- | PIN No. | DIM "L" | | |
|---------|----------------|---------------|---------------|
| | 4.25 \pm 0.1 | 3.5 \pm 0.1 | 5.0 \pm 0.1 |
| OTHERS | 36.67 | 17.54 | 35.51.68 |
- GENERAL TOLERANCE : \pm 0.3
 - IF LEAD FREE P/N. THE HOUSING WILL WITHSTAND EXPOSURE TO 260°C PEAK TEMPERATURE
SOLDER TAIL : SMT-IL, SMT-STG CAN RESIST 40 SECONDS IN A CONVECTION, INFRARED OR VAPOR PHASE REFLOW OVEN.
SOLDER TAIL : R/A CAN RESIST 10 SECONDS IN A WAVE SOLDER APPLICATION WITH A 1.00MM MINIMUM THICK CIRCUIT BOARD.
 - IF LEAD FREE P/N PACKAGING MEETS GS-14-920 SPECIFICATION
 - PRODUCT SPEC:110-263

mat'l. code	surface ISO1302	tolerance ISO1101 ISO406	projection 	product family MCS
l trechn nodr date	tolerances unless otherwise specified		ϕ	title
D	angle $\frac{S}{C}$	0.X \pm 0.3	MM	68 POS. EJECTOR HEADER ASSY. FOR LOW VOLTAGE
	0 \pm 2'	0.XXX \pm 0.051	scale 1:1	
	dr S.DUESTERHOEFT	7/20/95		dwg no sheet3of5 size
	engr D.BRANN	7/20/95		95706 A4
	chr D.BRANN	7/20/95		
	appd D.BRANN	7/20/95		type Product Customer Drawing
sheet index	revision sheet			

PRODUCT NO.
95706-500/500LF
95706-501
95706-502

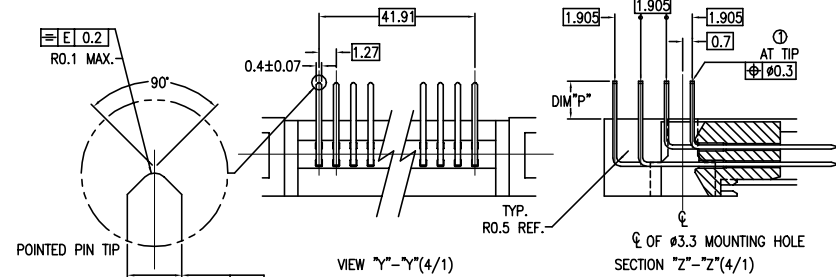
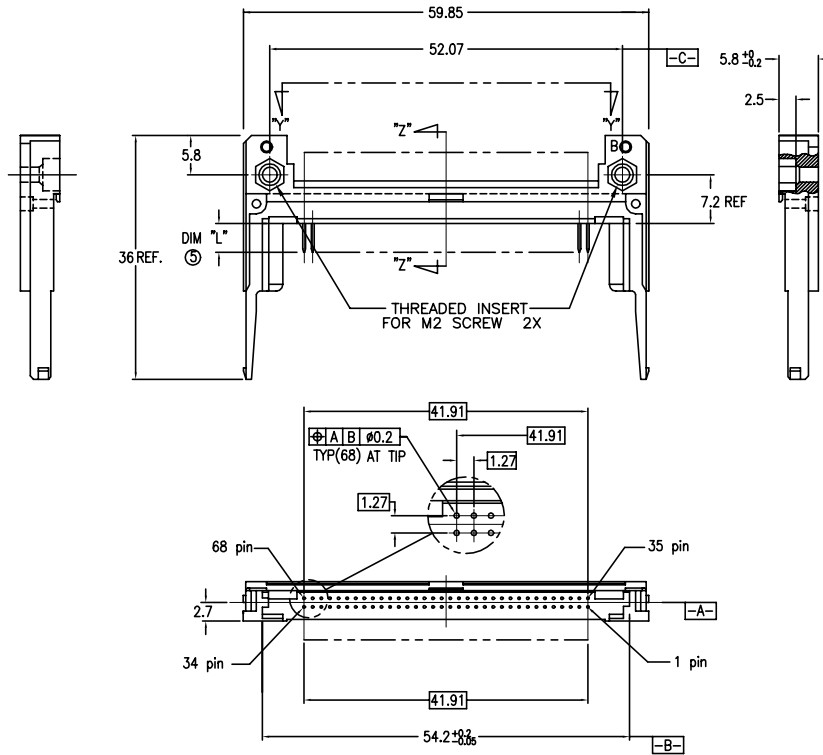

R/A (95706-500/500LF)

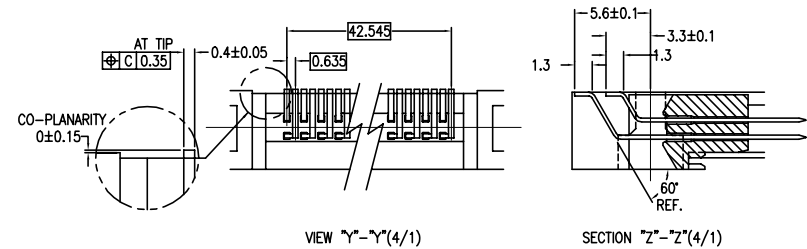

SMT STAGGERED (95706-501)

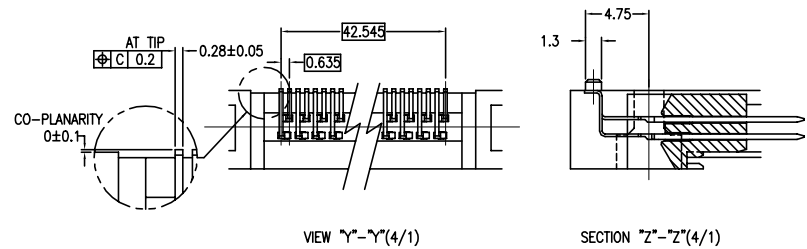

SMT IN LINE (95706-502)

NOTES

- ① TRUE POSITION IS A FREE GRID TO PIN PATTERN ITSELF
- ② SEE TA-946 FOR PCB LAYOUT
- ③ MATERIAL
HOUSING : HIGH TEMPERATURE THERMOPLASTIC UL94V-0 NATURAL
PIN : PHOSPHOR BRONZE
- ④ FINISH
PIN
UNDER PLATING : 0.5µm MIN. Ni
CONTACT AREA : 0.076 µm MIN. GOLD

SOLDER AREA(TIN LEAD OPTION): 2.5µm MIN. Sn-Pb
SOLDER AREA(LEAD FREE OPTION): 2.5µm MIN. PURE TIN

⑤ SEQUENCE PIN ASSIGNMENT

PIN No.	DIM "L"		
	OTHERS	36.67	1.17, 34, 35, 51, 68
	4.25±0.1	3.5±0.1	5.0±0.1

- 6 GENERAL TOLERANCE : ±0.3
- 7 IF LEAD FREE P/N. THE HOUSING WILL WITHSTAND EXPOSURE TO 260°C PEAK TEMPERATURE
SOLDER TAIL : SMT-IL, SMT-STG CAN RESIST 40 SECONDS IN A CONVECTION, INFRA-RED OR VAPOR PHASE REFLOW OVEN.
SOLDER TAIL : R/A CAN RESIST 10 SECONDS IN A WAVE SOLDER APPLICATION WITH A 1.00MM MINIMUM THICK CIRCUIT BOARD.
- 8 IF LEAD FREE P/N PACKAGING MEETS GS-14-920 SPECIFICATION
- 9 PRODUCT SPEC:110-263

mat'l. code	surface ISO1302 ✓	tolerance ISO1101 ISO406	projection MM	product family MCS
l trechn nodr date	tolerances unless otherwise specified		scale 1:1	title 68 POS. EJECTOR HEADER ASSY. FOR LOW VOLTAGE
D	angle 0°±2'	0.X±0.3 0.XX±0.13 0.XXX±0.051	dr S.DUESTERHOEFT 7/20/95	dwg no 95706 sheet 4 of 5 size A4
	engr D.BRANN 7/20/95	chr D.BRANN 7/20/95	appd D.BRANN 7/20/95	FCI logo
sheet index	revision sheet			type Product Customer Drawing

PRODUCT NO.
95706-510/510LF
95706-520/520LF
95706-540/540LF

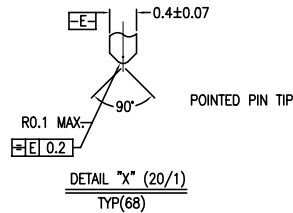
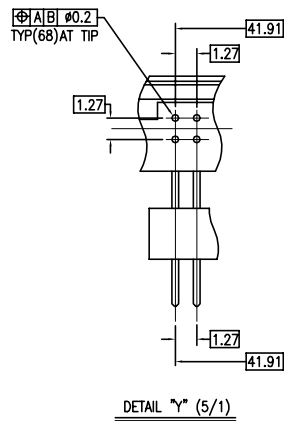
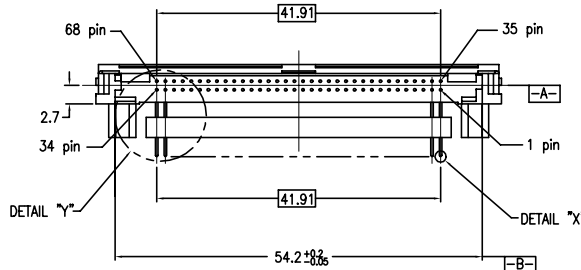
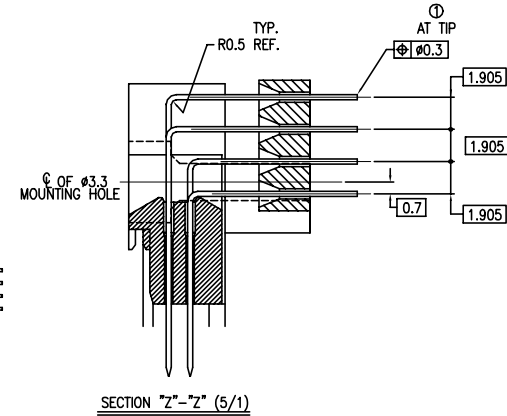
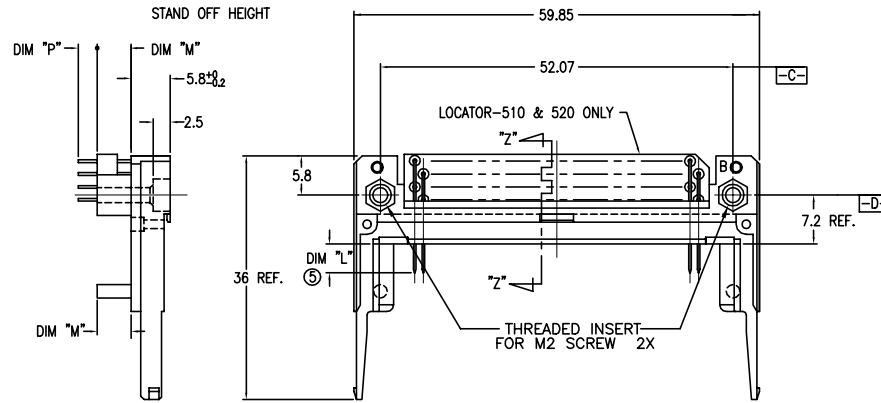

NOTES

- TRUE POSITION IS A FREE GRID TO PIN PATTERN ITSELF
- SEE TA-946 FOR PCB LAYOUT
- MATERIAL
HOUSING : HIGH TEMPERATURE THERMOPLASTIC UL94V-0 NATURAL
PIN : PHOSPHOR BRONZE
- FINISH PIN
UNDER PLATING : 0.5µm MIN. Ni
CONTACT AREA : 0.076 µm MIN. GOLD
SOLDER AREA(TIN LEAD OPTION): 2.5µm MIN. Sn-Pb
SOLDER AREA(LEAD FREE OPTION): 2.5µm MIN. PURE TIN
- SEQUENCE PIN ASSIGNMENT

	DIM "M"		
	4.25±0.1	3.5±0.1	5.0±0.1
PIN No.	OTHERS	36,67	1,17,34,35,68
- GENERAL TOLERANCE : ±0.3
- IF LEAD FREE P/N. THE HOUSING WILL WITHSTAND EXPOSURE TO 260°C PEAK TEMPERATURE
SOLDER TAIL : SMT-IL, SMT-STG CAN RESIST 40 SECONDS IN A CONVECTION, INFRA-RED OR VAPOR PHASE REFLOW OVEN.
SOLDER TAIL : R/A CAN RESIST 10 SECONDS IN A WAVE SOLDER APPLICATION WITH A 1.00MM MINIMUM THICK CIRCUIT BOARD.
- IF LEAD FREE P/N PACKAGING MEETS GS-14-920 SPECIFICATION
- PRODUCT SPEC:110-263

mat'l. code	surface ISO1302 ✓	tolerance ISO1101 ISO406	projection MM	product family MCS
l trechn nodr date	tolerances unless otherwise specified		scale 1:1	title 68 POS. EJECTOR HEADER ASSY. FOR LOW VOLTAGE
D	angle 0°±2'	0.X±0.3 0.XX±0.13 0.XXX±0.051	MM	dwg no 95706
	dr S.DUESTERHOEF	7/20/95	FCI	sheet 5 of 5 size A4
	enr D.BRANN	7/20/95		type Product Customer Drawing
	chr D.BRANN	7/20/95		
	appd D.BRANN	7/20/95		
sheet index	revision sheet			