

UHD MICRO DUAL TERMINATED PLUG
OVERMOLD GRAY (041S8058A)
M2132-2

625C166
MICRO UHD TERMINATED PLUG ASSEMBLY (2)

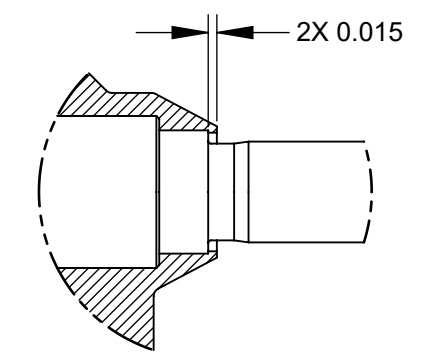

DETAIL B
SCALE 3 : 1

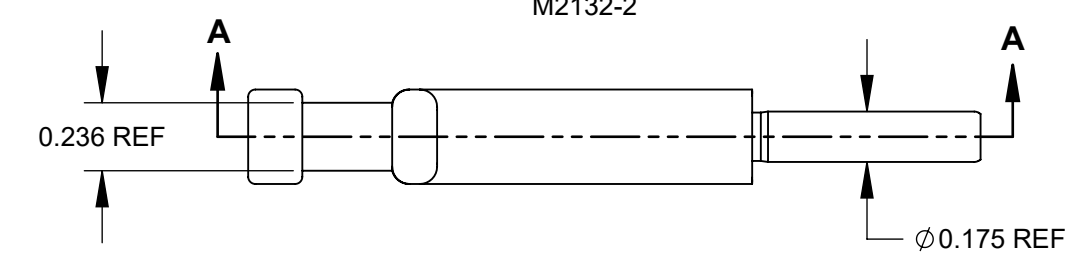
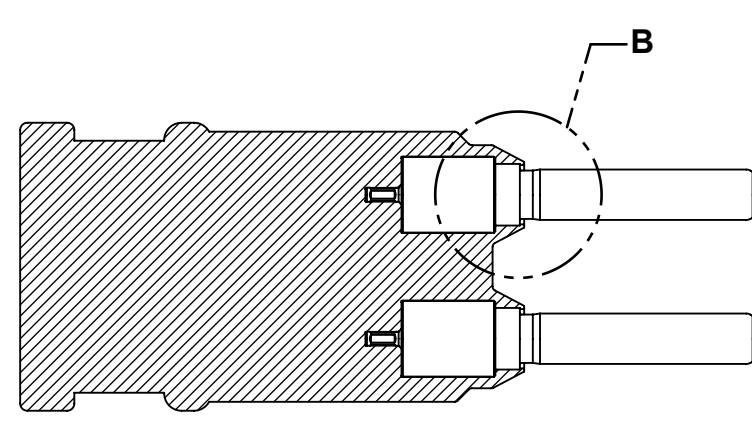
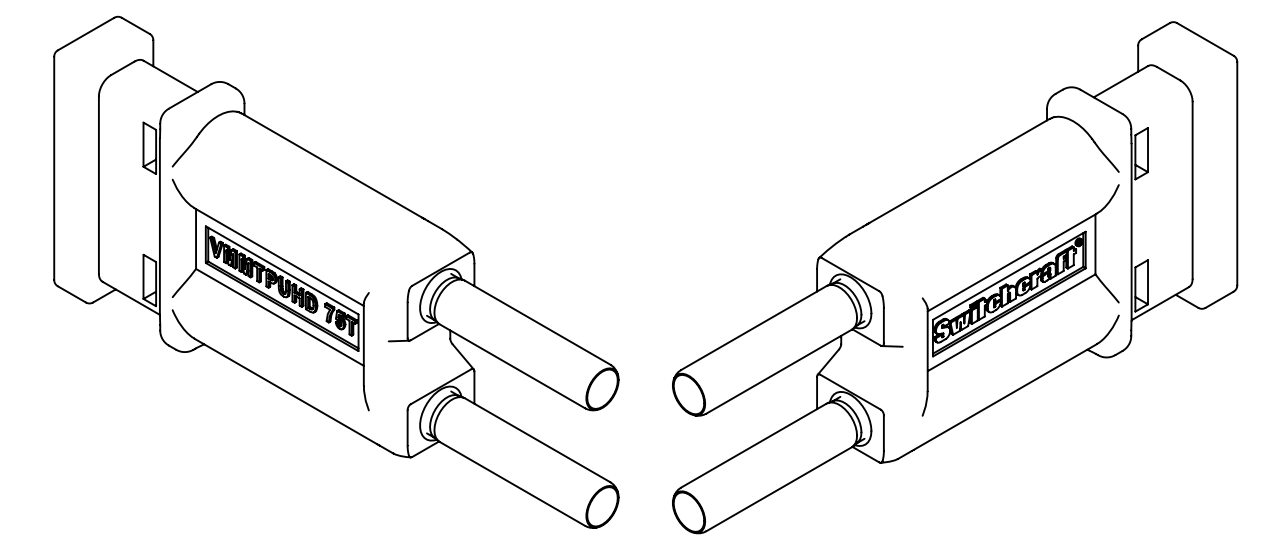

SECTION A-A

- NOTES:
1. MOLD; MC-287 (MICRO SIZE)
 2. OVERMOLD AND TEST.
 3. THIS PRODUCT IS RoHS COMPLIANT

REV	ECO NUMBER	DATE	BY	APVD
B	28606	6/20/23	TJK	TJK
A	28195	08/29/19	PC	TJK
REVISIONS				

☆ STAR SYMBOL DENOTES CRITICAL DIMENSION

UNLESS OTHERWISE SPECIFIED

1. ALL DIMENSIONS IN INCHES
- TWO PLACE DECIMALS ±0.01
- THREE PLACE DECIMALS ±0.005
- ANGLES ±1°
- ALL DIA. CONCENTRIC WITHIN 0.005 T.I.R.
2. FEATURES ON THE SAME CENTERLINE MUST BE ALIGNED WITHIN ±0.002
3. REMOVE ALL BURRS

DO NOT SCALE DRAWING

THIS DRAWING DESCRIBES A DESIGN CONSIDERED PROPRIETARY IN NATURE, DEVELOPED AND MANUFACTURED BY SWITCHCRAFT INC. AND IS RELEASED ON A CONFIDENTIAL BASIS FOR IDENTIFICATION PURPOSES ONLY.									
SIZE		WIDTH		MULT		LBS/M		TEMPER	
FINISH						MATERIAL			
SPEC No.						SPEC No.			
FIRST USED ON				SCALE		Switchcraft [®]			
				3:2					
DATE DRAWN	BY	CHKD	APVD						
8/18/16	PNK	PNK	SRC						
		8/18/16	8/18/16						
NAME DUAL TERMINATED PLUG UHD MICRO SWITCHCRAFT, RoHS						PART No.		REV	
						VMMTPUHD		B	