



## SPECIFICATION FOR APPROVAL

Customer : STD

Description : CONTROL BOARD

Customer Part No. \_\_\_\_\_ REV. : \_\_\_\_\_

Delta Model No. : FC241B07-L0E REV. : 00

Sample Issue No. : \_\_\_\_\_

Sample Issue Date : JUL.13 2020

PLEASE SEND ONE COPY OF THIS SPECIFICATION BACK AFTER YOU SIGNED APPROVAL FOR PRODUCTION PRE-ARRANGMENT.

APPROVED BY:

DELTA ELECTRONICS, INC.  
TAOYUAN PLANT  
252, SHANG YING ROAD, KUEI SAN INDUSTRIAL ZONE  
TAOYUAN SHIEN, TAIWAN, R.O.C.  
TEL:886-(0)3-3591968  
FAX:886-(0)3-3591991

Delta Electronics, Inc.  
No.252, Shanying Rd., Guishan Dist.,  
Taoyuan City 333, Taiwan (R.O.C.)

TEL : 886-(0)3-3591968  
FAX : 886-(0)3-3591991

## STATEMENT OF DEVIATION

NONE

DESCRIPTION:

## Specification For Approval

Customer : STD

Description : CONTROL BOARD

Customer P/N :

Rev. :

Delta model no. : FC241B07-L0E

Delta Safety Model No.:

Sample revision. : 00

Issue no.:

Sample issue date : JUL.13 2020

Quantity :

**1. SCOPE:**

THIS CONTROL BOARD IS THE DRIVER OF BFN0724SS-01 SERIES AND THE SPEED CONTROL METHOD IS OPEN LOOP.

**2. CHARACTERS:**

VAID AT AMBIENT=25 °C, INPUT VOLTAGE IS 24Vdc AND FREE AIR.

ITEM	DESCRIPTION
CONFIGURATION	BLDC 3PHASE / 6PULSE/4POLE (DEDICATED TO THE DELTA BLOWER BFN0724SS-01)
RATED VOLTAGE	24Vdc±10%
INPUT CURRENT (FREE AIR)(AVG) ★	1.50 (MAX. 1.80) A
INPUT POWER(FREE AIR)(AVG) ★	36.0 (MAX. 43.2) W
SPEED (FREE AIR)	31500±10% R.P.M.
SPEED (AT ZERO AIR FLOW)	36000±10% R.P.M.
OPERATING TEMPERATURE	-10 ~ 50 °C
OPERATING HUMIDITY (NO CONDENSATION)	10 ~ 90%RH
STORAGE TEMPERATURE	-20 ~ 60 °C
STORAGE HUMIDITY (NO CONDENSATION)	10 ~ 50%RH

★AVG. IS THE AVERAGE VALUE DURING STEADY OPERATION, AND MAX. IS MAXIMUM AVERAGE VALUE INCLUDED RODUCTION TOLERANCE. ABOUT THE PEAK VALUE, NEED TO USE OSCILLOSCOPE TO MEASURE.

(continued)

PART NO:

DELTA MODEL: FC241B07-L0E

3. INTERFACE:

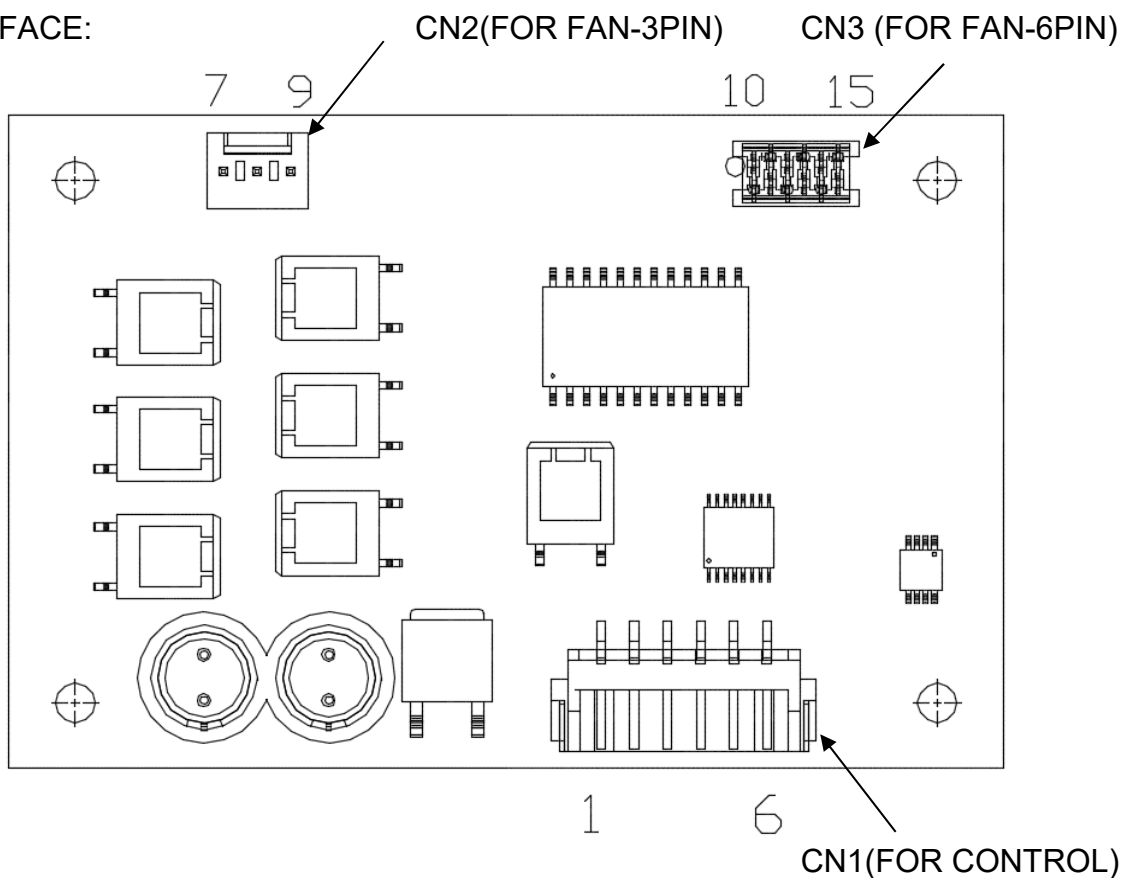

PIN NO.	SYMBOL	SIGNAL	WIRE COLOR
1	VIN	INPUT VOLTAGE	RED
2	GND	GND	BLACK
3	PWM	SPEED CONTROL SIGNAL	YELLOW
4	FG	SPEED SIGNAL OUTPUT	BLUE
5	BRAKE-L	SHORT BRAKE INPUT	GREEN
6	ERROR	ERROR SIGNAL	PURPLE
7	U	MOTOR COIL(U)	BLUE(FAN)
8	W	MOTOR COIL(W)	RED(FAN)
9	V	MOTOR COIL(V)	BLACK(FAN)
10	HALL 1	HALL IC INPUT 1	RED(FAN)
11	HALL 3	HALL IC INPUT 3	GRAY(FAN)
12	GND	GND	GRAY(FAN)
13	HALL 2	HALL IC INPUT 2	GRAY(FAN)
14	NTC	TERMISTOR	GRAY(FAN)
15	+UH	HALL IC POWER	GRAY(FAN)

---

PART NO:

---

DELTA MODEL: FC241B07-L0E

---

4. MOTOR PHASE SCEQUENCE:

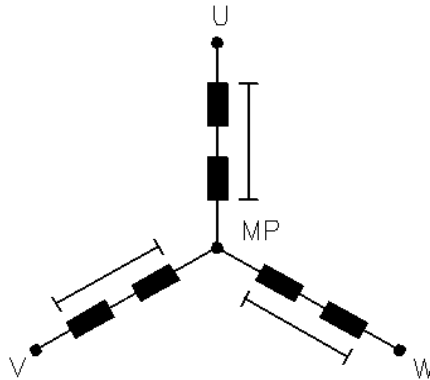
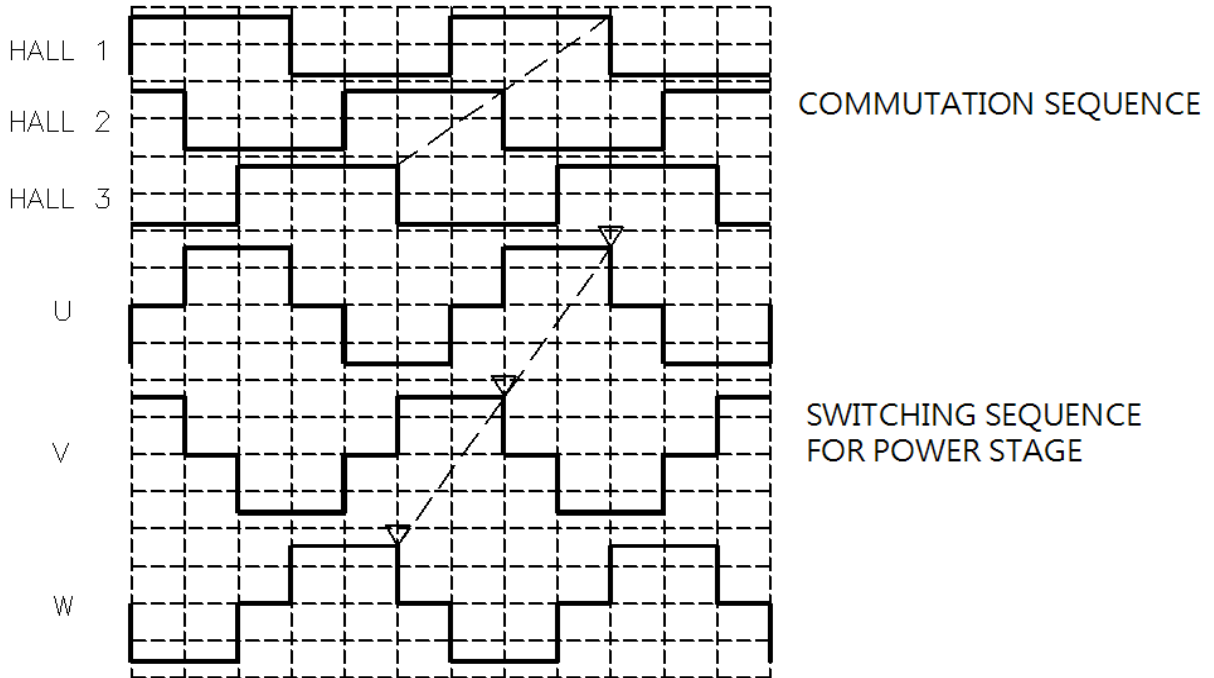

PART NO:

DELTA MODEL: FC241B07-L0E

5. PWM CONTROL SIGNAL:

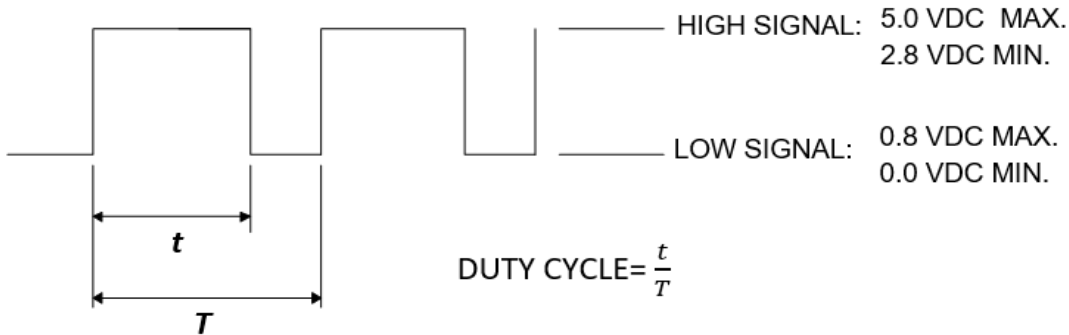

5-1. THE PREFERRED OPERATING FREQUENCY IS 25KHz.

5-2. AT 0-3% DUTYCYCLE, THE CLOWER WILL STOP.

5-3. WITH CONTROL SIGNAL LEAD DISCONNECTED, THE BLOWER WILL SPIN AT MAXIMUM SPEED.

5-4. THE SPEED CONTROL METHOD IS OPEN LOOP.

5-5. AT 25KHz, RATED VOLTAGE, 20% DUTY CYCLE, THE BLOWER WILL BE ABLE TO START FROM A DEAD STOP.

5-6. SPEED VS PWM CONTROL SIGNAL. (AT 25 °C, 24Vdc AND FREE AIR CONDITION)

DUTY CYCLE (%)	SPEED (RPM)	CURRENT (A) ★
85-100	31500±10%	1.5
0-3	0	0.03

6. PWM CONTROL LEAD WIRE INPUT IMPEDANCE:

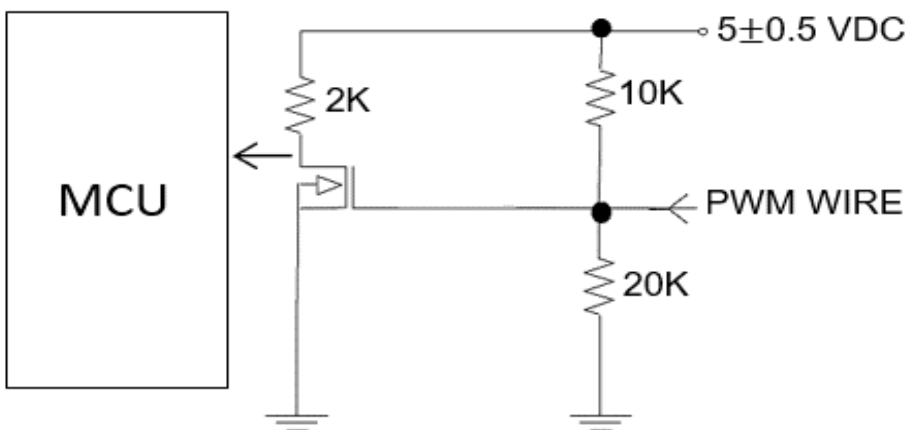

---

PART NO:

---

DELTA MODEL: FC241B07-L0E

---

7. PROTECTION DEFINITION:

7-1. OVER TEMPERATURE PROTECTION (OTP)

THE BLOWER WILL STOP(LATCH MODE) WHEN THE THERMISTOR OF BLOWER EXCEEDS 85 °C (FOR REFERENCE). THE RED LIGHT(LED3) WILL TURN ON.

7-2. LOCK MODE

THE FG SIGNAL OUTPUTS HIGH OR LOW WHEN THE ROTOR IS LOCKED AND FIXED.

7-3. OVER VOLTAGE PROTECTION (OVP)

THE BLOWER WILL BE STOP WHEN THE INPUT VOLTAGE IS OVER 28V (FOR REFERENCE).

7-4. HIGH SPEED LIMIT PROTECTION

THE HIGH SPPED LIMIT OF BLOWER IS 40000RPM (FOR REFERENCE).

8. ERROR SIGNAL

WHEN THE PROTECTION IS LAUNCHED, THE ERROR PIN WILL OUTPUT SINL AS BELOW TABLE (THE FREQUENCY IS 1KHz AND THE AMPLITUDE IS 5V).

MODE	DUTY (FOR REFERENCE)
LOCK	10%
HIGH SPEED	20%
OVP	30%
OTP	40%

---

PART NO:

---

DELTA MODEL: FC241B07-L0E

---

### 9. FREQUENCY GENERATOR (FG) SIGNAL:

#### 9-1. OUTPUT CIRCUIT-OPEN COLLECTOR MODE.

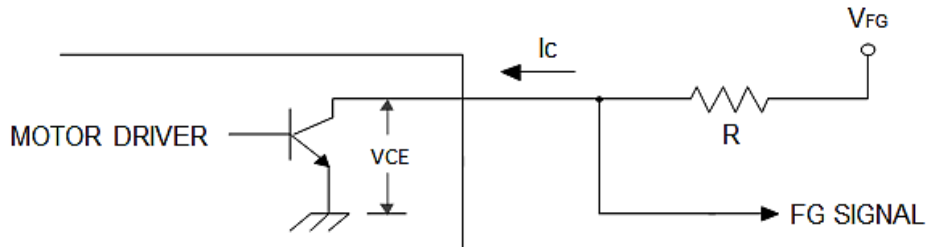

CAUTION: THE LEAD WIRE OF FG SIGNAL CAN NOT TOUCH THE LEAD WIRE OF POSITIVE OR NEGATIVE.

#### 9-2. SPECIFICATION:

$V_{FG} = 26.4 \text{ Vdc max.}$        $I_c = 5 \text{ mA max.}$

$V_{ce(sat)} = 0.5 \text{ V max.}$        $R \geq V_{fg}/I_c.$

#### 9-3. FREQUENCY GENERATOR WAVEFORM:

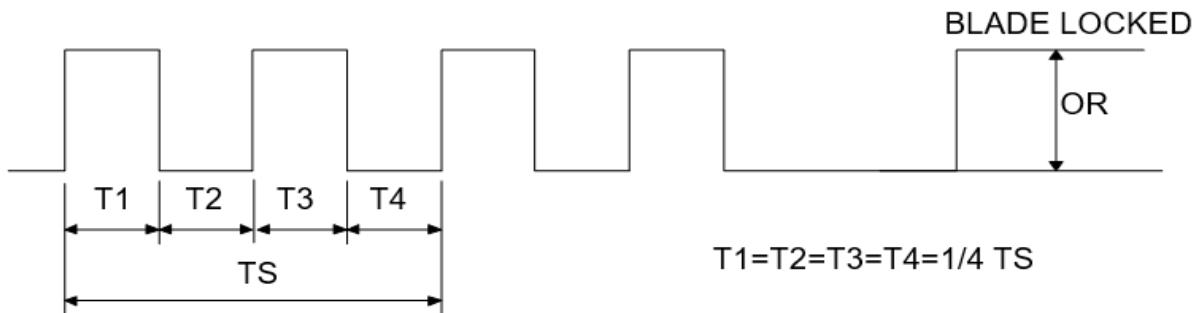

$N = \text{RPM}$

$T_s = 60/N(\text{SEC})$

VOLTAGE LEVEL AFTER BLADE LOCKED.

4 POLE

### 10. BRAKE FUNCTION:

10-1. THE BLOWER WILL BE SHORT BRAKE WHEN THE BRAKE PIN IS LOW (NOT EXCEED 2.0 SEC).

10-2. THE BLOWER WILL ROTATE NORMALLY WHEN THE BRAKE PIN IS FLOATING.

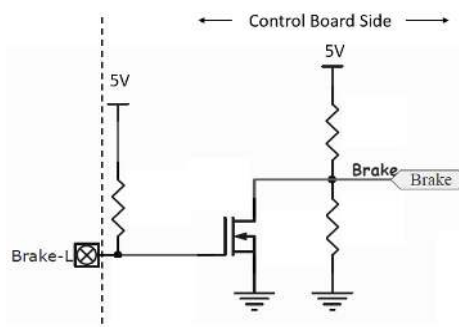



PART NO:

DELTA MODEL: FC241B07-L0E

### 11. DIMENSION DRAWING

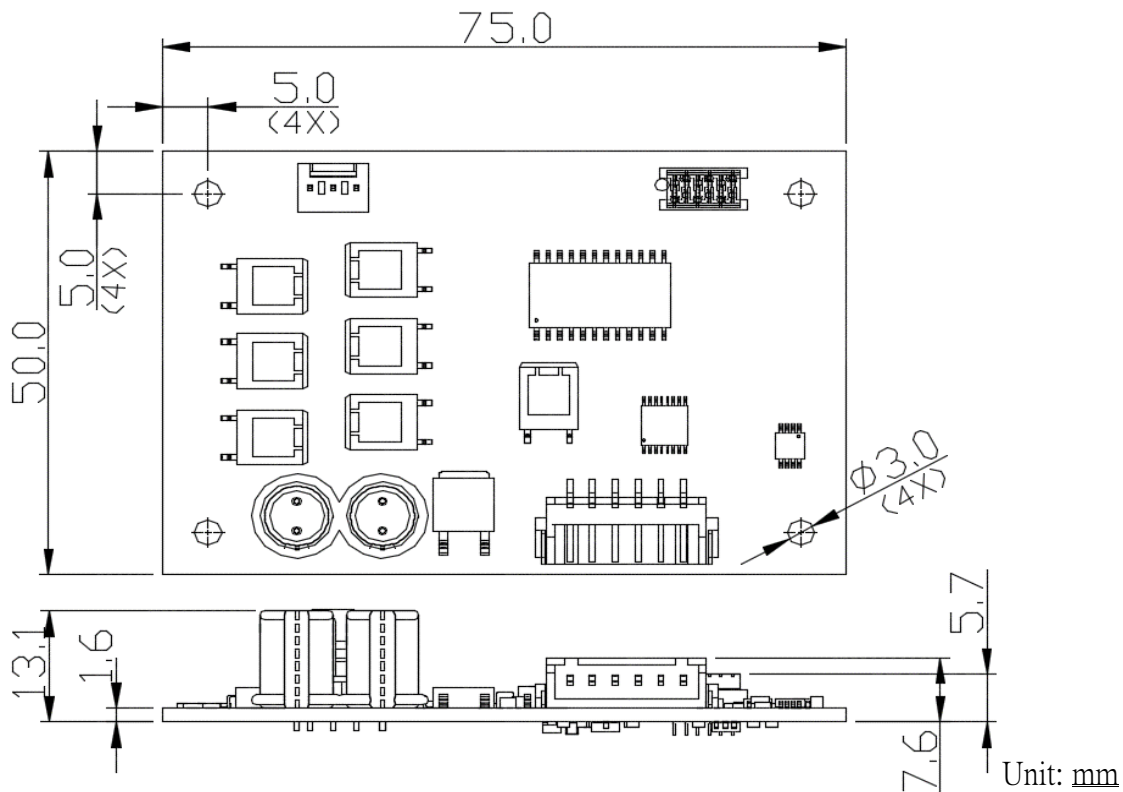

### 12. EXTENSION WIRE:

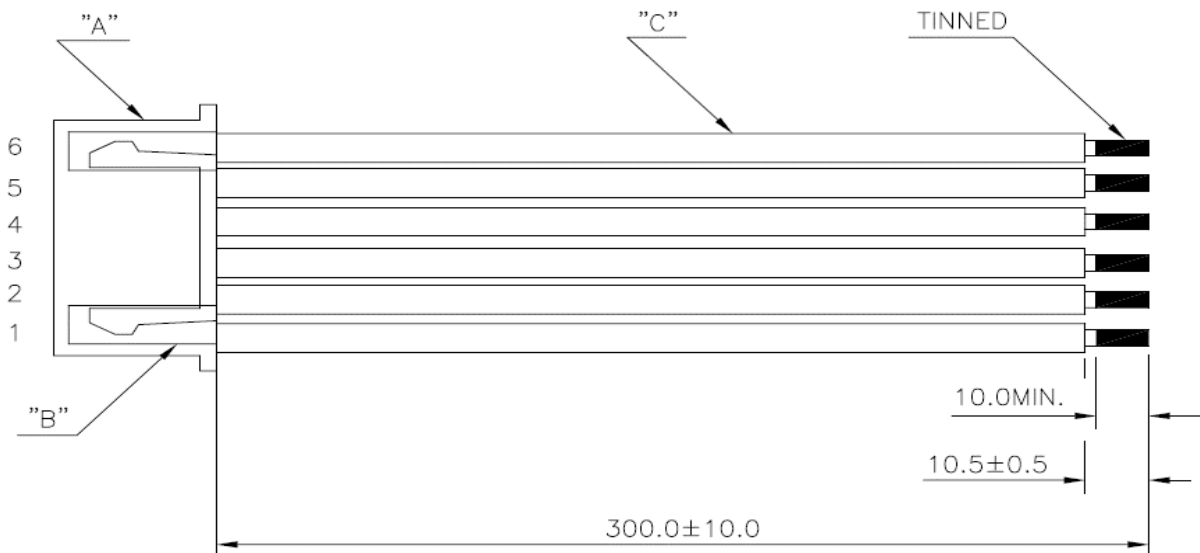

#### MATERIAL:

- A. HOUSING: J.S.T P/N: XHP-6 OR EQUIVALENT -----1PC
- B. TERMINAL: J.S.T P/N: SXH-001T-0.6 OR EQUIVALENT ----2PCS
- C. LEAD WIRE UL:1007 AWG#24
  - PIN 1: RED WIRE ---- (+)
  - PIN 2: BLACK WIRE ---- (-)
  - PIN 3: YELLOW WIRE ---- (PWM)
  - PIN 4: BLUE WIRE ---- (FG)
  - PIN 5: GREEN WIRE ---- (BRAKE)
  - PIN 6: PURPLE WIRE ---- (ERROR)



## ***Application Notice***

- 1. Delta will not guarantee the performance of the products if the application condition falls outside the parameters set forth in the specification.**
- 2. A written request should be submitted to Delta prior to approval if deviation from this specification is required.**
- 3. Please exercise caution when handling fans. Damage may be caused when pressure is applied to the impeller, if the fans are handled by the lead wires, or if the fan was hard-dropped to the production floor.**
- 4. Except as pertains to some special designs, there is no guarantee that the products will be free from any such safety problems or failures as caused by the introduction of powder, droplets of water or encroachment of insect into the hub.**
- 5. The above-mentioned conditions are representative of some unique examples and viewed as the first point of reference prior to all other information.**
- 6. It is very important to establish the correct polarity before connecting the fan to the power source. Positive (+) and Negative (-). Damage may be caused to the fans if connection is with reverse polarity, if there is no foolproof method to protect against such error specifically mentioned in this spec.**
- 7. Delta fans without special protection are not suitable where any corrosive fluids are introduced to their environment.**
- 8. Please ensure all fans are stored according to the storage temperature limits specified. Do not store fans in a high humidity environment. We highly recommend performance testing is conducted before shipping, if the fans have been stored over 6 months.**
- 9. Not all fans are provided with the Lock Rotor Protection feature. If you impair the rotation of the impeller for the fans that do not have this function, the performance of those fans will lead to failure.**
- 10. Please be cautious when mounting the fan. Incorrect mounting of fans may cause excess resonance, vibration and subsequent noise.**
- 11. It is important to consider safety when testing the fans. A suitable fan guard should be fitted to the fan to guard against any potential for personal injury.**
- 12. Except where specifically stated, all tests are carried out at room (ambient) temperature and relative humidity conditions of 25°C. 65% RH. The test value is only for fan performance itself.**
- 13. Be certain to connect an “ 4.7µF or greater” capacitor to the fan externally when the application calls for using multiple fans in parallel, to avoid any unstable power.**
- 14. If the product is used with medical related field or other types of equipment that affect people's lives, advanced preparation of safety-related evaluations is mandatory.**
- 15. It should be avoided that product is using or storing in the environment, such as strong shocks, magnetic or electromagnetic noise, and which the electromagnetic noise overlaps into power voltage. This might cause the product breakdown or abnormal operation.**
- 16. Do not use the product in a flammable gas environment or explosive dust environment.**
- 17. If the product is used in extremely high reliable environment, such as medical/military equipment or other application. Please consult with Delta Electronics, Inc. before adopting in these applications.**