

Unit CAM

SKU:U109

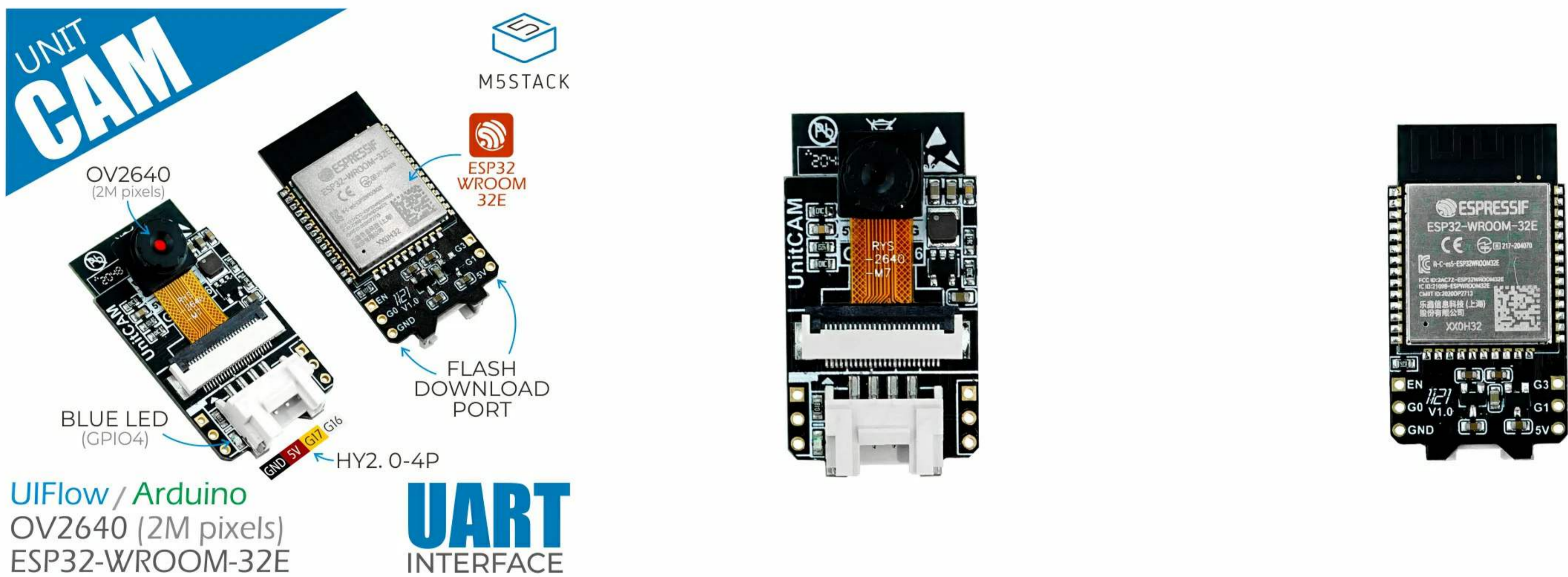

Description

Unit CAM M5 launched a very cost-effective WiFi camera, using ESP32-WROOM-32E control core + 2MegaPixel image sensor (OV2640) solution on the hardware, using the most simplified design, no extra peripherals. The factory software integrates image transmission firmware, provides image data acquisition, image parameter (white balance, exposure, gain, size and other attributes) adjustment interface, users can directly acquire image data through UART or WiFi, and interact with the camera. Support UIFlow graphical programming call, realize zero development, out-of-the-box user experience. The compact design and cost performance are suitable for various wireless camera application scenarios.

Product Features

- Simplified design
- ESP32 control core
- 2MegaPixel camera (OV2640)
- UART communication (support image data acquisition, image parameter adjustment and other interfaces)
- WIFI image transmission
- Programming platform: ESP-IDF/Arduino/UIFlow

Include

- 1x Unit CAM

Applications

- WiFi camera
- Remote monitoring

Specification

Resources	Parameter
Flash	4M
Firmware default communication method	UART: 115200bps 8N1
Camera	OV2640
Maximum resolution	2MegaPixel
Unit CAM firmware default picture transfer rate	12fps
OV2640 supports output format	YUV(422/420)/YCbCr422, 8-bit compressed data, RGB565/555, 8-/10-bit Raw RGB data
OV2640 supports the maximum image transfer rate	UXGA/SXGA: 15fps, SVGA: 30fps, CIF: 60fps
DFOV	66.5°
Net weight	4.7g
Gross weight	5.3g
Product Size	45*20*12mm
Package Size	60*60*15mm

Flash Download

Unit CAM does not include a program download circuit. When users need to download the ESP32 update program, they can burn the program through an external connection with a USB-TTL downloader.

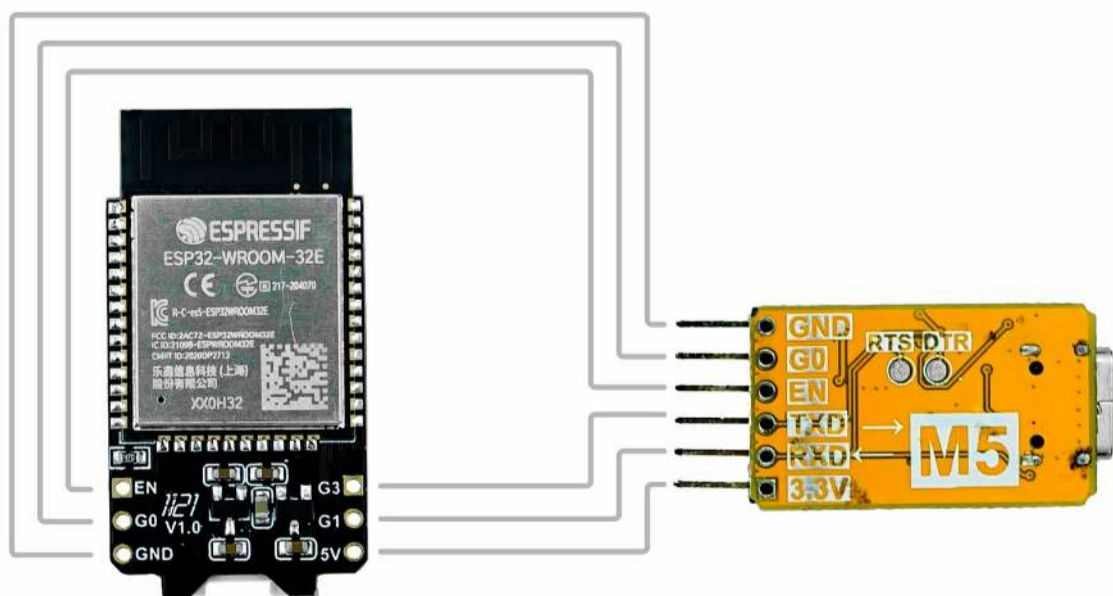

PinMap

OV2640 Interface

Interface	Camera Pin	Unit CAM
SCCB Clock	SIOC	IO23

SCCB Data Interface	SIOD Camera Pin	IO25 Unit CAM
System Clock	XCLK	IO27
Vertical Sync	VSYNC	IO22
Horizontal Reference	HREF	IO26
Pixel Clock	PCLK	IO21
Pixel Data Bit 0	D0	IO32
Pixel Data Bit 1	D1	IO35
Pixel Data Bit 2	D2	IO34
Pixel Data Bit 3	D3	IO5
Pixel Data Bit 4	D4	IO39
Pixel Data Bit 5	D5	IO18
Pixel Data Bit 6	D6	IO36
Pixel Data Bit 7	D7	IO19
Camera Reset	RESET	IO15
Camera Power Down	PWDN	-1
Power Supply 3.3V	3V3	3V3
Ground	GND	GND

HY2.0-4P Interface

HY2.0-4P	Unit CAM
RX	IO16
TX	IO17
5V	5V
GND	GND

LED (blue)

LED	Unit CAM
D1	IO4

Schematic

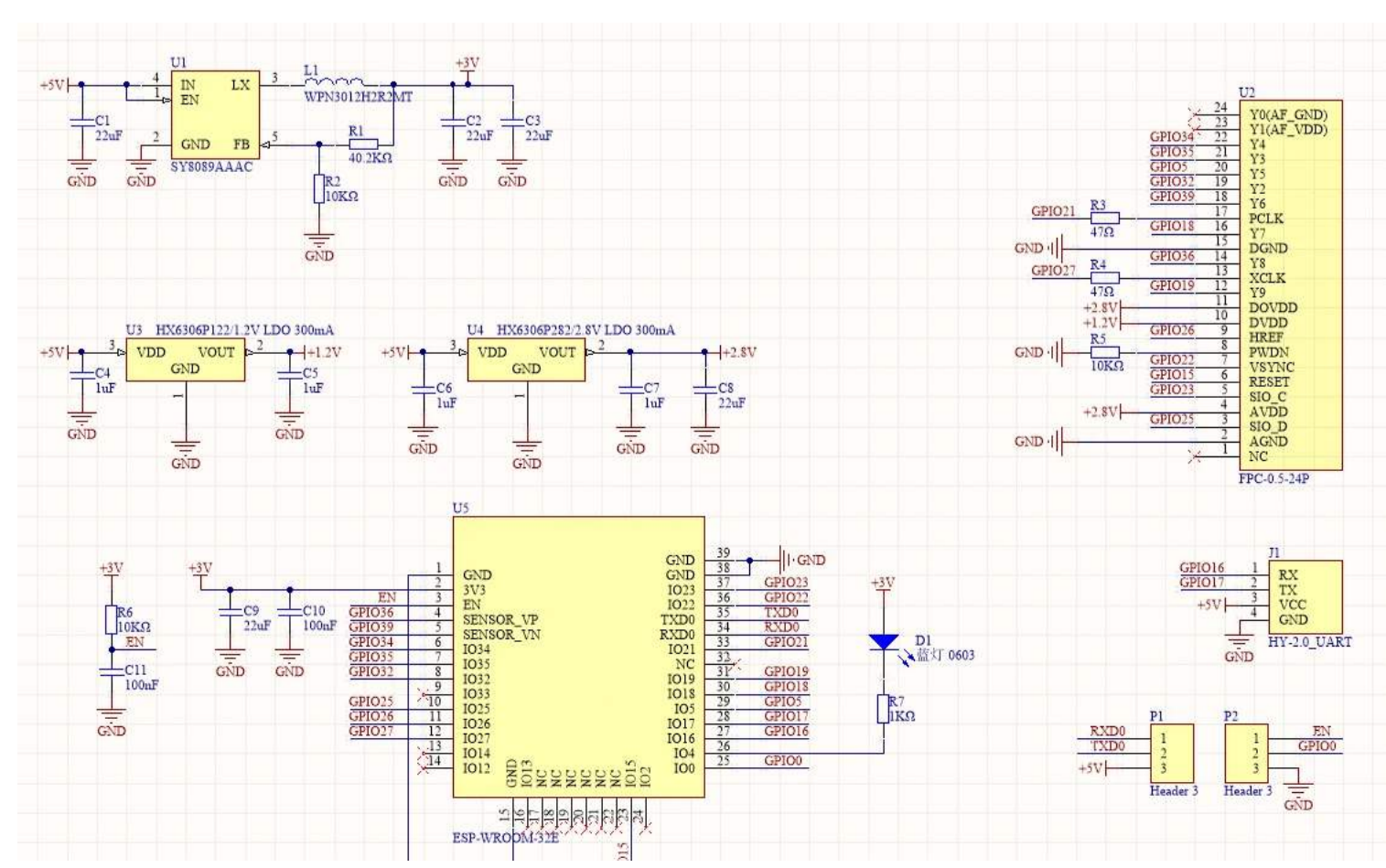

Related Link

- **Datasheet**
 - [ESP32-WROOM-32E](#)
 - [OV2640](#)

Example

Arduino

- [Camera UART to Core](#)

UIFlow

UnitCAM's default factory firmware supports two working modes: UART and WiFi. WiFi mode supports timed shooting and automatically uploads pictures to the M5 cloud and returns to the picture calling interface (URL). Under UART mode, users can use other master devices to obtain picture frames and modify picture parameters through UART communication.

Unit CAM UIFlow Block Instructions

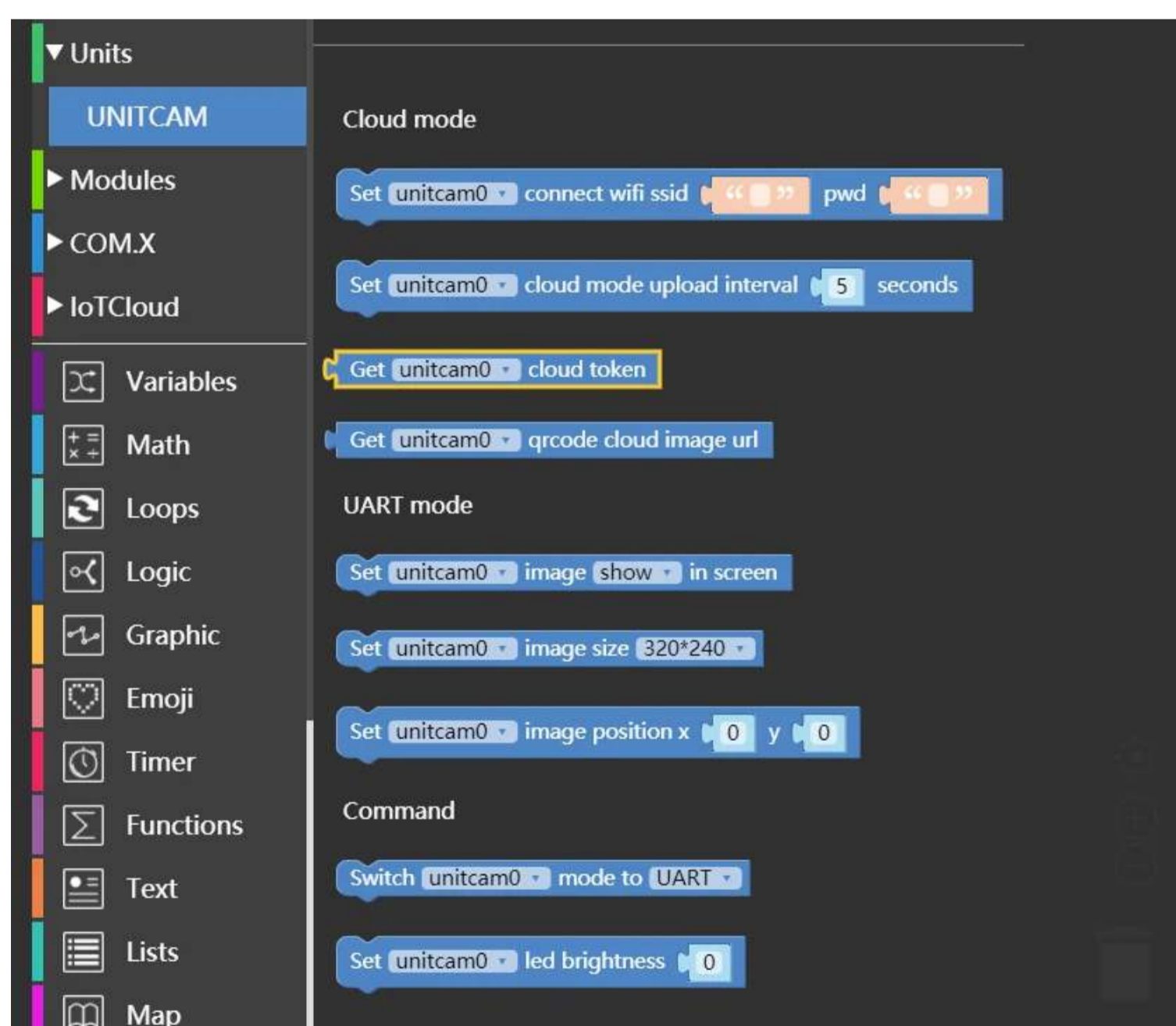

Unit CAM UIFlow Use Case

Press A to enable WiFi connection mode, connect to the designated WiFi, the camera takes pictures at 5s intervals and upload them to the M5 cloud, and press B to obtain the camera Token, and use the cloud image URL generated by the Token to create a QR code.

Press C to enable UART connection mode, configure the picture size to be 320*240, and start the picture display thread to continuously refresh the picture to the screen.

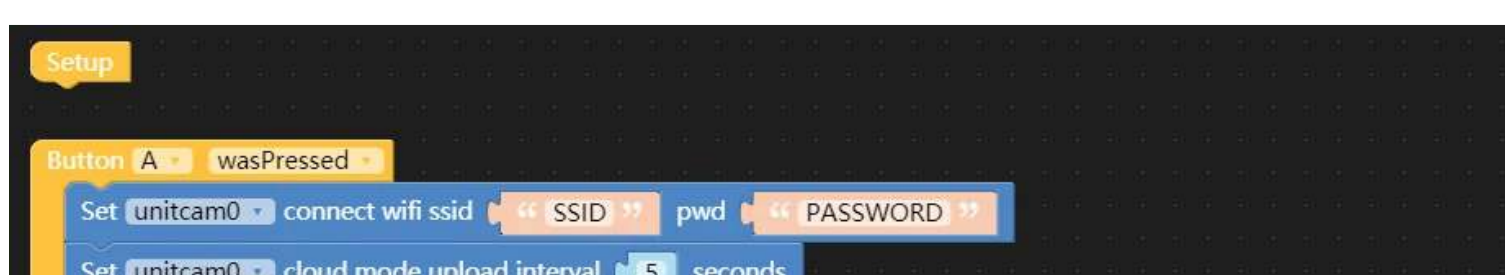

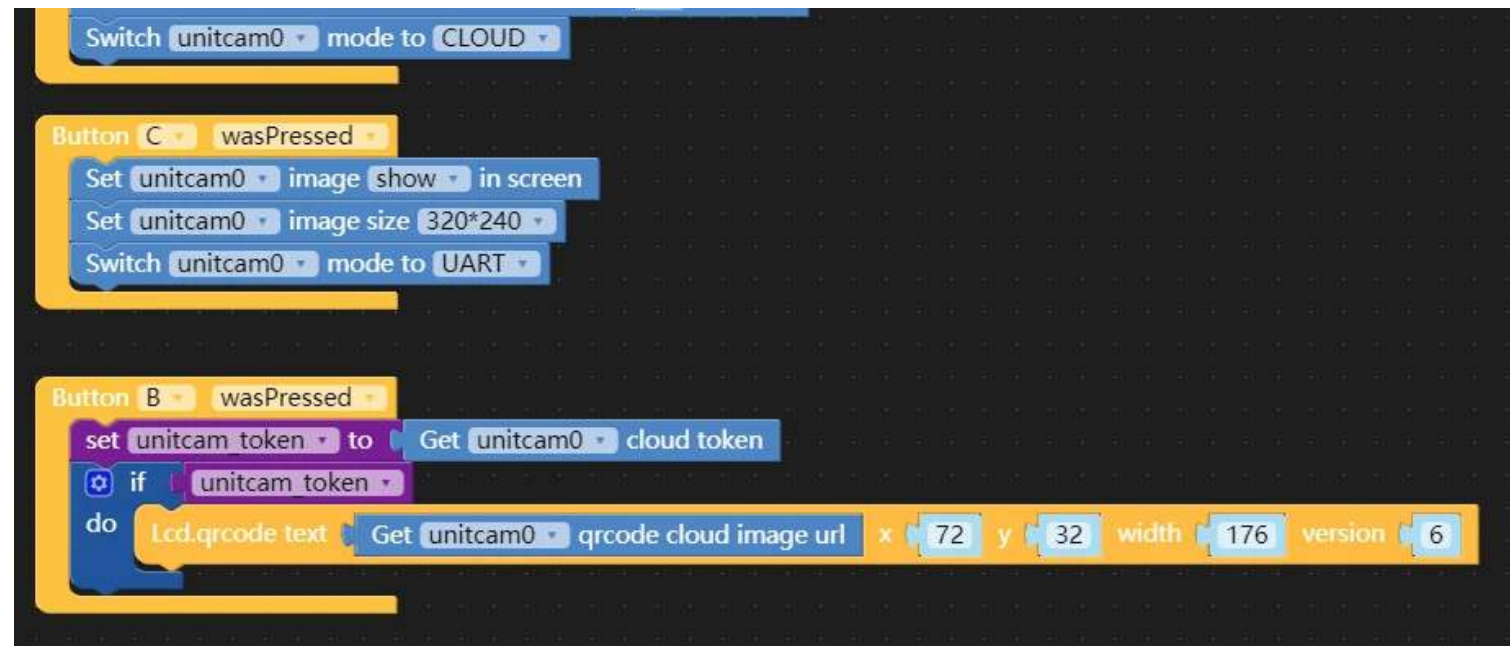

Unit CAM UIFlow Block function description:

- Cloud Mode Functions:

#Configure the camera to connect to the specified WiFi

Set-unitcam-connect-wifi-ssid

#Configure the camera image upload cloud interval

Set-unitcam-cloud-mode-upload-interval

#Get camera Token

Get-unitcam-cloud-token

#Get the URL of the camera cloud image

Get-unitcam-cloud-image-url

- UART Mode Functions:

#In UART mode, start the screen display image thread, the default display coordinates are 0,0

Set-unitcam-image-show-in-screen

#Set the camera to return the image size

Set-unitcam-image-size

#Set the image display position

Set-unitcam-image-position-x-y

- Command:

#Switch UART/CLOUD mode

Switch-unitcam-mode-to-UART/CLOUD

#Set the brightness of the onboard LED of the camera

Set-unitcam, led-brightness

Micropython API

```
import unit
```

#Create unitcam instance

```
unitcam0 = unit.get(unit.UNITCAM, unit.PORTB)
```

#UART Mode: unitcam0.UART_MODE

#WiFi mode: unitcam0.CLOUD_MODE

```
unitcam0.set_mode(unitcam0.UART_MODE)
```

#WiFi mode, configure the camera to connect to the specified WiFi

```
unitcam0.set_wifi('', '')
```

```
#WiFi mode, configure the camera image upload cloud interval
unitcam0.set_upload_time(5)

#Get camera token
unitcam_token = unitcam0.get_token()

#Stitching a fixed domain name field to get the URL of the camera cloud image
unicam_image_url = 'camera.m5stack.com/timer-cam/image?tok=' + unitcam0.get_token()

#UART mode, start the screen display image thread, the default display coordinates are 0,0
unitcam0.set_show(True)

#Set the camera to return the image size
#unitcam0.SIZE_800_600
#unitcam0.SIZE_640_480
#unitcam0.SIZE_320_240
#unitcam0.SIZE_240_240
#unitcam0.SIZE_160_120
unitcam0.set_image_size(unitcam0.SIZE_320_240)

#Set Unit CAM onboard LED brightness value: 0~100
unitcam0.set_led_brightness(0)
```

| Video
