

# AT-64023

## Up to 4 GHz Linear Power Silicon Bipolar Transistor



### Data Sheet

#### Description

The AT-64023 is a high performance NPN silicon bipolar transistor housed in a hermetic BeO flange package for good thermal characteristics. This device is designed for use in medium power, wide band amplifier and oscillator applications operating over VHF, UHF and microwave frequencies.

Excellent device uniformity, performance and reliability are produced by the use of ion-implantation, self-alignment techniques, and gold metallization in the fabrication of these devices. The use of ion-implanted ballast resistors ensures uniform current distribution through the multiple emitter fingers.

#### 230 mil BeO Package

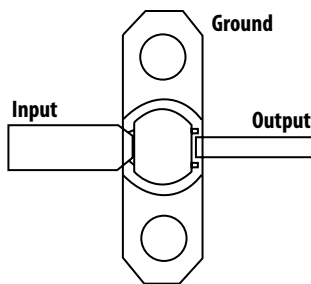

#### Features

- High Output Power:  
27.5 dBm Typical  $P_{1\text{ dB}}$  at 2.0 GHz  
26.5 dBm Typical  $P_{1\text{ dB}}$  at 4.0 GHz
- High Gain at 1 dB Compression:  
12.5 dB Typical  $G_{1\text{ dB}}$  at 2.0 GHz  
9.5 dB Typical  $G_{1\text{ dB}}$  at 4.0 GHz
- 35% Total Efficiency
- Emitter Ballast Resistors
- Hermetic, Metal/Beryllia Stripline Package

## AT-64023 Absolute Maximum Ratings

Symbol	Parameter	Units	Absolute Maximum <sup>[1]</sup>
V <sub>EBO</sub>	Emitter-Base Voltage	V	2.2
V <sub>CBO</sub>	Collector-Base Voltage	V	40
V <sub>CEO</sub>	Collector-Emitter Voltage	V	20
I <sub>C</sub>	Collector Current	mA	200
P <sub>T</sub>	Power Dissipation <sup>[2,3]</sup>	W	3
T <sub>j</sub>	Junction Temperature	°C	200
T <sub>STG</sub>	Storage Temperature	°C	-65 to 200

### Thermal Resistance<sup>[2,4]</sup>:

$$\theta_{jc} = 40^{\circ}\text{C}/\text{W}$$

#### Notes:

1. Permanent damage may occur if any of these limits are exceeded.
2. T<sub>CASE</sub> = 25°C.
3. Derate at 25 mW/°C for T<sub>c</sub> > 80°C.
4. The small spot size of this technique results in a higher, though more accurate determination of  $\theta_{jc}$  than do alternate methods. See MEASUREMENTS section "Thermal Resistance" for more information.

## Electrical Specifications, T<sub>A</sub> = 25°C

Symbol	Parameters and Test Conditions	Units	Min.	Typ.	Max.
S <sub>21E</sub>   <sup>2</sup>	Insertion Power Gain; V <sub>CE</sub> = 16 V, I <sub>C</sub> = 110 mA	f = 2.0 GHz f = 4.0 GHz		6.5 2.0	
P <sub>1 dB</sub>	Power Output @ 1 dB Gain Compression V <sub>CE</sub> = 16 V, I <sub>C</sub> = 110 mA	f = 2.0 GHz f = 4.0 GHz		27.5 26.5	
G <sub>1 dB</sub>	1 dB Compressed Gain; V <sub>CE</sub> = 16 V, I <sub>C</sub> = 110 mA	f = 2.0 GHz f = 4.0 GHz		12.5 9.5	
η <sub>T</sub>	Total Efficiency <sup>[1]</sup> at 1 dB Compression: V <sub>CE</sub> = 16 V, I <sub>C</sub> = 110 mA	f = 4.0 GHz		35.0	
h <sub>FE</sub>	Forward Current Transfer Ratio; V <sub>CE</sub> = 8 V, I <sub>C</sub> = 110 mA	—	20	50	200
I <sub>CBO</sub>	Collector Cutoff Current; V <sub>CB</sub> = 16 V	μA			100
I <sub>EBO</sub>	Emitter Cutoff Current; V <sub>EB</sub> = 1 V	μA			5.0

#### Note:

1.  $\eta_T = (\text{RF Output Power}) / (\text{RF Input Power} + V_{CE}I_C)$ .

## AT-64023 Typical Performance, $T_A = 25^\circ\text{C}$

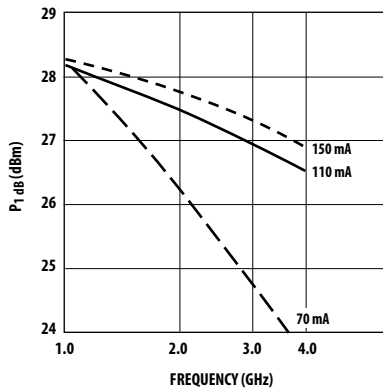

Figure 1. Power Output @ 1 dB Gain Compression vs. Frequency and Collector Current.  $V_{CE} = 16\text{ V}$ .

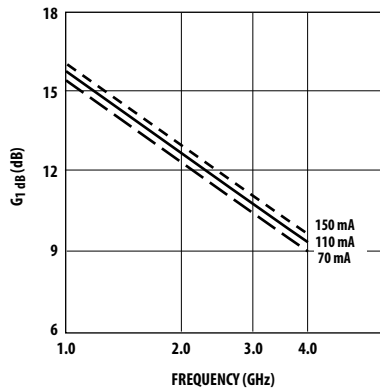

Figure 2. 1 dB Compressed Gain vs. Frequency and Collector Current.  $V_{CE} = 16\text{ V}$ .

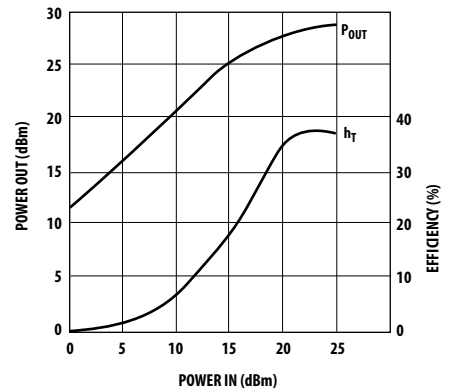

Figure 3. Output Power and Efficiency vs. Input Power.  $V_{CE} = 16\text{ V}$ ,  $I_C = 110\text{ mA}$ ,  $f = 4.0\text{ GHz}$ .

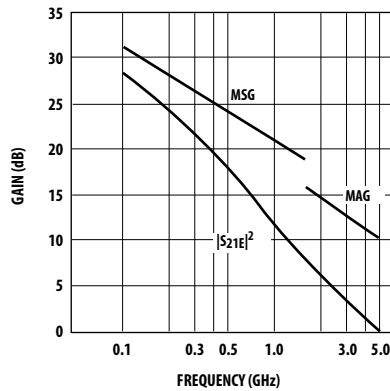

Figure 4. Insertion Power Gain, Maximum Available Gain and Maximum Stable Gain vs. Frequency.  $V_{CE} = 16\text{ V}$ ,  $I_C = 110\text{ mA}$ .

## Typical Scattering Parameters, Common Emitter, $Z_O = 50\Omega$ , $T_A = 25^\circ\text{C}$ , $V_{CE} = 16\text{ V}$ , $I_C = 110\text{ mA}$

Freq. GHz	$S_{11}$			$S_{21}$			$S_{12}$		$S_{22}$	
	Mag.	Ang.	dB	Mag.	Ang.	dB	Mag.	Ang.	Mag.	Ang.
0.1	.54	-124	28.2	25.71	135	-33.3	.022	42	.72	-51
0.5	.80	-178	17.6	7.57	78	-29.5	.034	18	.33	-119
1.0	.80	162	11.9	3.92	47	-28.6	.037	10	.33	-142
1.5	.80	147	8.6	2.70	21	-27.9	.040	12	.40	-156
2.0	.78	133	6.3	2.07	-4	-27.6	.042	1	.48	-169
2.5	.77	127	5.1	1.80	-24	-25.5	.053	-5	.58	-178
3.0	.73	116	3.8	1.56	-51	-25.0	.056	-20	.67	170
3.5	.66	106	2.9	1.40	-79	-25.8	.051	-28	.78	156
4.0	.60	99	2.2	1.28	-109	-27.2	.044	-49	.86	142
4.5	.55	98	1.4	1.18	-141	-31.2	.028	-70	.93	127
5.0	.54	99	0.6	1.07	-175	-40.9	.009	-144	.93	112

S-parameters at other bias conditions are available on the Avago Design Pak disk.

## Ordering Information

Part Number	No. of Devices
AT-64023	10

## 230 mil BeO Package Dimensions

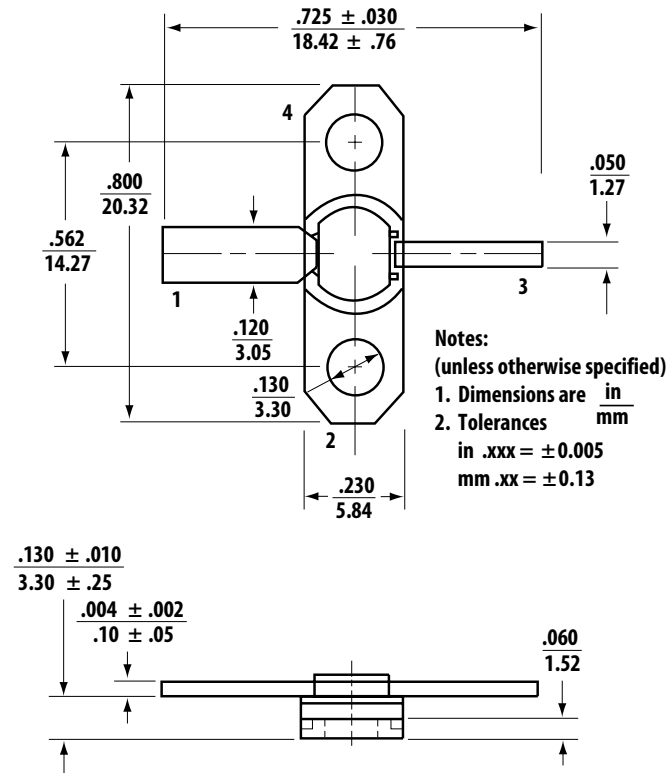

For product information and a complete list of distributors, please go to our web site: [www.avagotech.com](http://www.avagotech.com)

Avago, Avago Technologies, and the A logo are trademarks of Avago Technologies in the United States and other countries. Data subject to change. Copyright © 2005-2008 Avago Technologies. All rights reserved. Obsoletes 5989-2658EN AV02-1221EN - November 24, 2008

**Avago**  
TECHNOLOGIES