

CF-LD

Hyper-Miniature Lever Switches

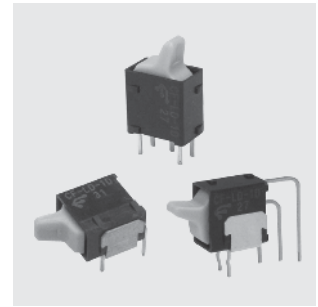

RoHS Compliant

Features

1. Light operating feeling.
2. Auto soldering on PC board is possible (non-washable).
3. Three mounting types of PC/Right Angle/Vertical are available.
4. The gold-plated clip contact mechanism ensures high contact reliability.
5. Lever design, considering the operability. Three lever colors of white, red, and gray are lined up.

Switching Function

Switching function		
A POS.	B POS.	
ON	ON	
(5) - (6)	(5) - (4)	

Specifications

Rating	Max.	0.4VA (28VAC/DC 0.1A) (Resistive load)
	Min.	20mVAC/DC 0.1mA (Resistive load)
Dielectric strength	500VAC 1minute	
Initial contact resistance	80mΩ Max. (1.5mA 200μVAC)	
Initial insulation resistance	500MΩ Min. (500VDC)	
Electrical life	10,000 cycles at max. rating	
	50,000 cycles at VA0.4 rating & min.	
Mechanical life	50,000 cycles	
Operating temperature range	-40~+85°C	
Storage temperature range	-40~+85°C	

Internal Structure

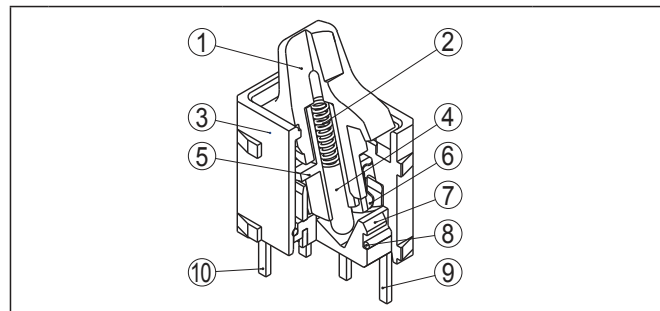

Part name	Material	Flammability
① Lever	PA(Polyamide)	UL94V-0
② C Spring	Piano wire	—
③ Cover	PA(Polyamide)	UL94V-0
④ Actuator tip	Copper alloy, Nickel-plated	—
⑤	PA(Polyamide)	UL94V-0
⑥ Movable contact	Copper alloy, Gold-plated	—
⑦ Base	PA(Polyamide)	UL94V-0
⑧ O Ring	Nitrile rubber	—
⑨ Terminal(Circuit)	Copper alloy, Gold-plated	
⑩ Terminal(Dummy) ※PC only	Copper alloy, Tin-plated	

Part Numbering

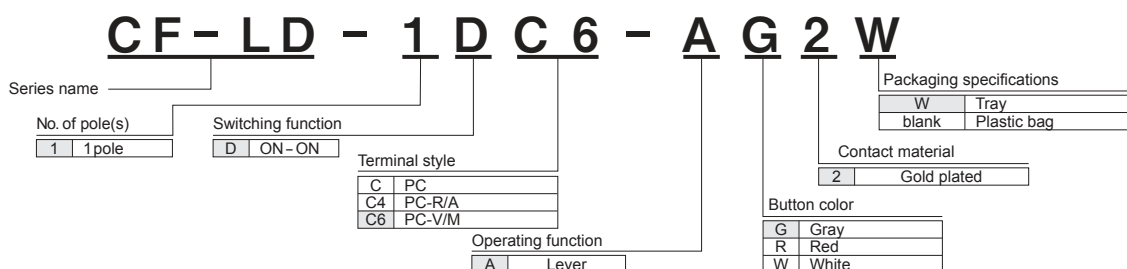

List of Part Numbers

★Made to order products

No.of pole(s)	Switching function	Packaging specifications	Button color	Terminal styles			Pieces in package
				PC	PC-R/A	PC-V/M	
1	D	Tray	Gray	★CF-LD-1DC-AG2W	★CF-LD-1DC4-AG2W	CF-LD-1DC6-AG2W	200pcs./tray
			Red	★CF-LD-1DC-AR2W	★CF-LD-1DC4-AR2W	★CF-LD-1DC6-AR2W	200pcs./tray
			White	★CF-LD-1DC-AW2W	★CF-LD-1DC4-AW2W	★CF-LD-1DC6-AW2W	200pcs./tray
		Plastic bags	Gray	★CF-LD-1DC-AG2	★CF-LD-1DC4-AG2	CF-LD-1DC6-AG2	25pcs./pack
			Red	★CF-LD-1DC-AR2	★CF-LD-1DC4-AR2	★CF-LD-1DC6-AR2	25pcs./pack
			White	★CF-LD-1DC-AW2	★CF-LD-1DC4-AW2	★CF-LD-1DC6-AW2	25pcs./pack

Outline Dimensions

Tolerances unless otherwise specified:±0.3 (Unit:mm)

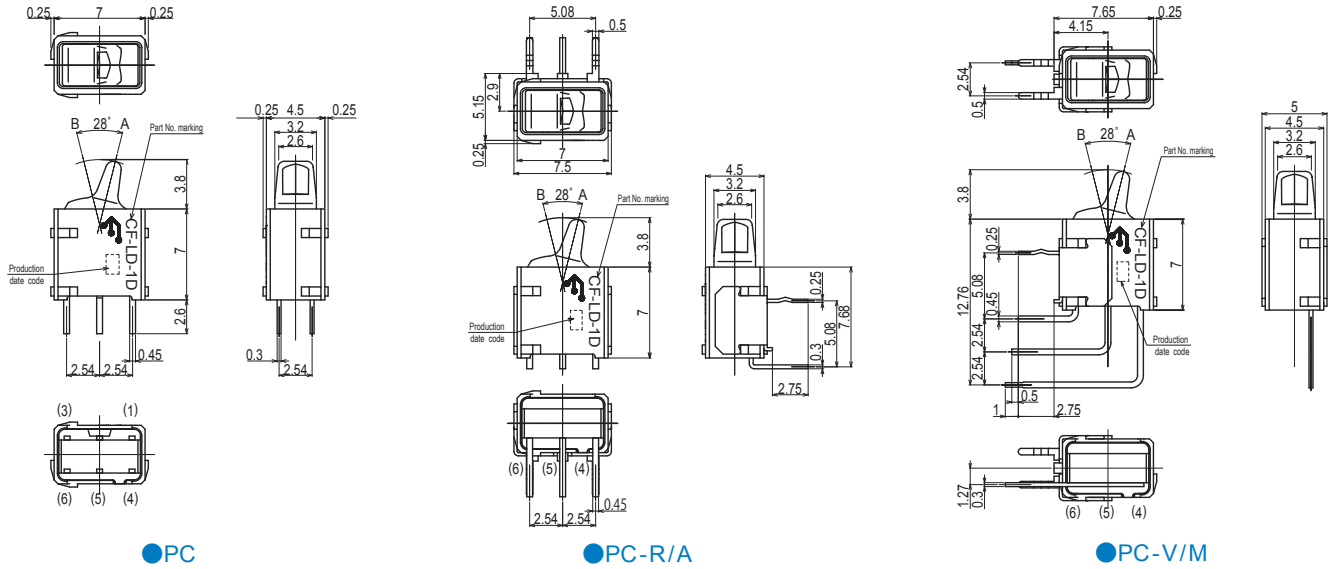

PC Hole Layouts

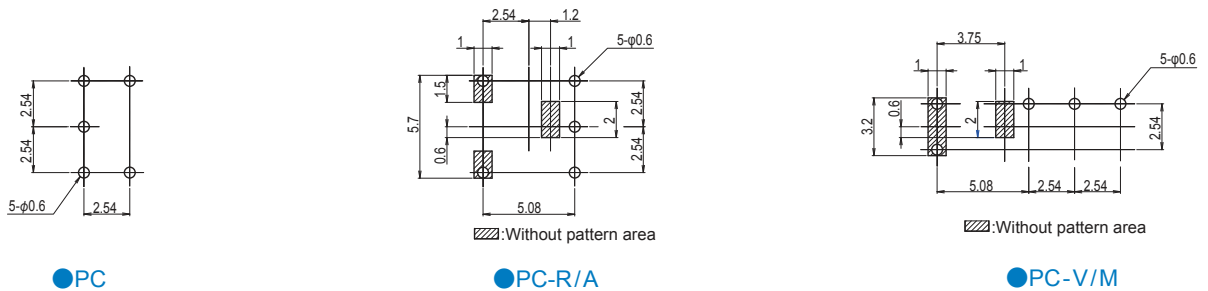

Soldering Specifications

(1) Auto Soldering

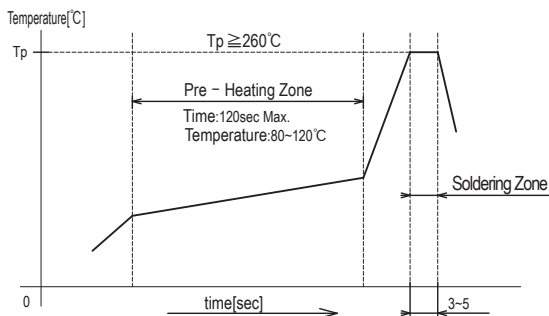

(2) Manual Soldering

Device: Soldering iron
350°C, Max.; 3 seconds, Max.

Packaging Specification

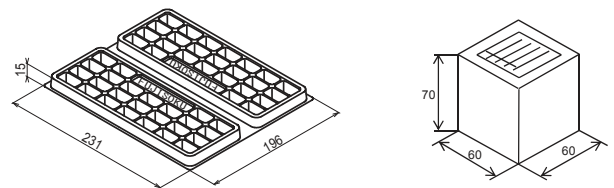

●Tray: 100pcs.

●Plastic bag: 25pcs.