

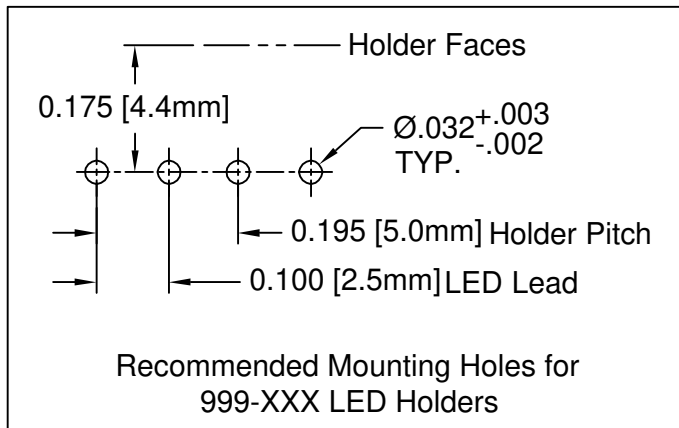

REV.	DESCRIPTION	DATE	APPROVED
B	Engineering Update w/o Changes	02/24/04	M. C.

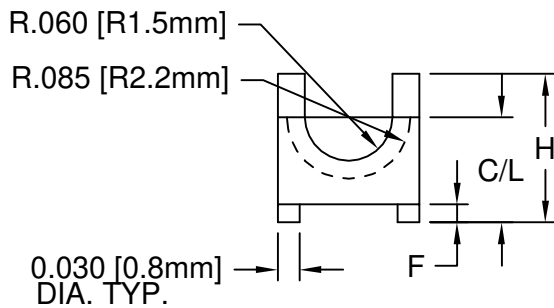
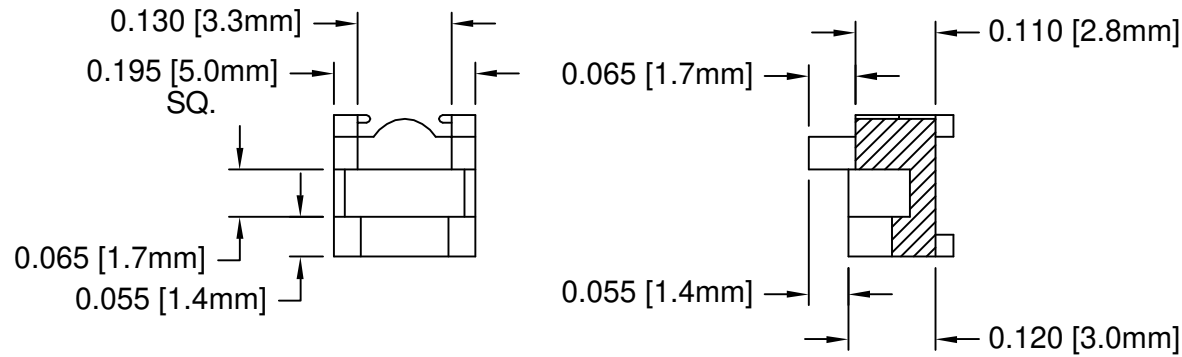

PART NO.	MT'L	C/L	H	F
999-125	A	.125"(3.2mm)	.180"(4.6mm)	.000"
999-125 BK	B			
999-150	A	.150"(3.8mm)	.205"(5.2mm)	.025"(.64mm)
999-150 BK	B			
999-175	A	.175"(4.4mm)	.230"(5.8mm)	.050"(1.3mm)
999-175 BK	B			
999-200	A	.200"(5.1mm)	.255"(6.5mm)	.075"(1.9mm)
999-200 BK	B			

3. MATERIAL B: NYLON 6/6, 94V-2, BLACK. BIVAR MATERIAL CODE 03-NL-BK. BASF ULTRAMID NYLON 6/6 A3K NATURAL W/BLACK PIGMENT ADDED.
2. MATERIAL A: NYLON 6/6, 94V-2, NATURAL. BIVAR MATERIAL CODE 03-NL. BASF ULTRAMID NYLON 6/6 A3K NATURAL.
1. GENERAL SPECIFICATIONS: BIVAR MOLDED COMPONENT SPECIFICATION BV00-E101.

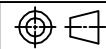
STANDARD TOLERANCE (UNLESS OTHERWISE SPECIFIED)		 BIVAR [®] 4 THOMAS, IRVINE, CA. 92618 TEL: (949) 951-8808 FAX: (949) 951-3974	
DECIMALS	ANGULAR		
.X ±.1	X° ±1°	 TITLE: T1 (3mm) VARIABLE CENTERLINE LED HOLDER	
.XX ±.01			
.XXX ±.005			
DESIGNED: Shane Irving	DATE: 06/03/98	PART NO: 999-XXX XX	REVISION: B
CHECKED: M. Chen	DATE: 02/24/03	CAGE CODE : 32559	SHEET # 1 OF 1
CAD GENERATED DOCUMENT, DO NOT MEASURE DRAWING.			