

## MEMS audio sensor omnidirectional digital microphone

Datasheet - production data

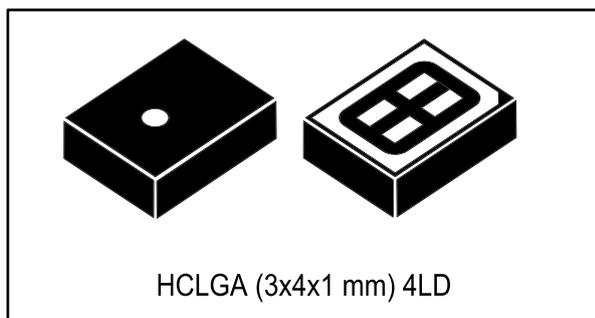

### Features

- Single supply voltage
- Low power consumption
- 120 dB SPL acoustic overload point
- 63 dB signal-to-noise ratio
- Omnidirectional sensitivity
- -26 dBFS sensitivity
- PDM output
- HCLGA package
  - Top-port design
  - SMD-compliant
  - EMI-shielded
  - ECOPACK<sup>®</sup>, RoHS, and “Green” compliant

### Applications

- Mobile terminals
- Laptop and notebook computers
- Portable media players
- VoIP
- Speech recognition
- A/V eLearning devices
- Gaming and virtual reality input devices
- Digital still and video cameras
- Antitheft systems

### Description

The MP34DT01 is an ultra-compact, low-power, omnidirectional, digital MEMS microphone built with a capacitive sensing element and an IC interface.

The sensing element, capable of detecting acoustic waves, is manufactured using a specialized silicon micromachining process dedicated to produce audio sensors.

The IC interface is manufactured using a CMOS process that allows designing a dedicated circuit able to provide a digital signal externally in PDM format.

The MP34DT01 has an acoustic overload point of 120 dB SPL with a 63 dB signal-to-noise ratio and -26 dBFS sensitivity.

The MP34DT01 is available in a top-port, SMD-compliant, EMI-shielded package and is guaranteed to operate over an extended temperature range from -40 °C to +85 °C.

**Table 1: Device summary**

Order codes	Temp. range [°C]	Package	Packing
MP34DT01	-40 to +85	HCLGA (3x4 x1 mm) 4LD	Tray
MP34DT01TR	-40 to +85	HCLGA (3x4x1 mm) 4LD	Tape and reel

**Contents**

**1 Pin description ..... 5**

**2 Acoustic and electrical specifications ..... 6**

    2.1 Acoustic and electrical characteristics..... 6

    2.2 Timing characteristics ..... 7

    2.3 Frequency response ..... 8

**3 Carrier tape mechanical specifications ..... 9**

**4 Process recommendations ..... 10**

**5 Sensing element ..... 12**

**6 Absolute maximum ratings..... 13**

**7 Functionality ..... 14**

    7.1 L/R channel selection..... 14

**8 Package information ..... 15**

    8.1 Soldering information ..... 15

    8.2 HCLGA package information..... 16

**9 Revision history ..... 19**

---

## List of tables

Table 1: Device summary .....	1
Table 2: Pin description .....	5
Table 3: Acoustic and electrical characteristics .....	6
Table 4: Distortion specifications .....	6
Table 5: Timing characteristics .....	7
Table 6: Frequency response mask for digital microphones .....	8
Table 7: Absolute maximum ratings .....	13
Table 8: L/R channel selection .....	14
Table 9: Recommended soldering profile limits.....	15
Table 10: HCLGA (3 x 4 x 1 mm) 4-lead package dimensions .....	17
Table 11: Document revision history .....	19

---

## List of figures

Figure 1: Pin connections .....	5
Figure 2: Timing waveforms .....	7
Figure 3: Frequency response and mask .....	8
Figure 4: Carrier tape without microphone (top view).....	9
Figure 5: Carrier tape with microphone (top view).....	9
Figure 6: Recommended picking area.....	10
Figure 7: Recommended picker design .....	11
Figure 8: Recommended soldering profile limits .....	15
Figure 9: HCLGA (3 x 4 x 1 mm) 4-lead package outline.....	16
Figure 10: Land pattern.....	18

# 1 Pin description

Figure 1: Pin connections

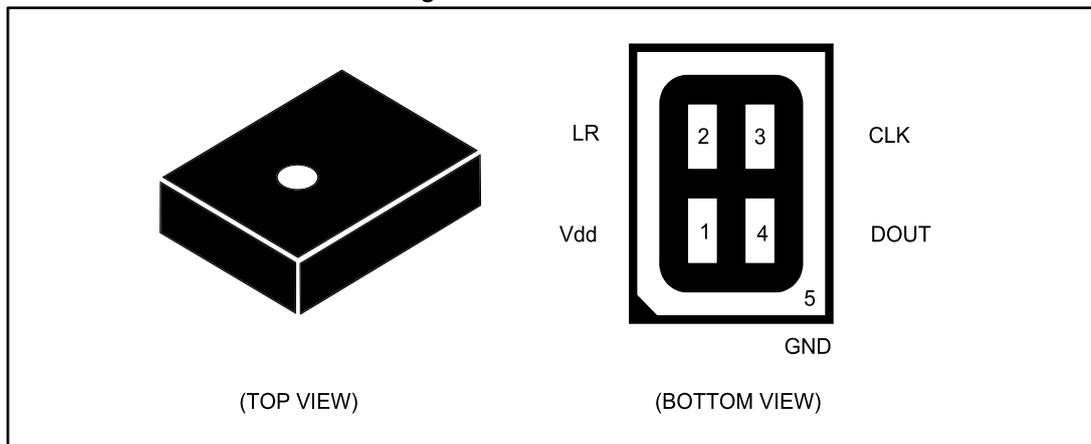

Table 2: Pin description

Pin #	Pin name	Function
1	Vdd	Power supply
2	LR	Left/Right channel selection
3	CLK	Synchronization input clock
4	DOUT	Left/Right PDM data output
5 (ground ring)	GND	0 V supply

## 2 Acoustic and electrical specifications

### 2.1 Acoustic and electrical characteristics

The values listed in the table below are specified for Vdd = 1.8 V, Clock = 2.4 MHz, T = 25 °C, unless otherwise noted.

**Table 3: Acoustic and electrical characteristics**

Symbol	Parameter	Test condition	Min.	Typ. <sup>(1)</sup>	Max.	Unit
Vdd	Supply voltage		1.64	1.8	3.6	V
Idd	Current consumption in normal mode	Mean value		0.6		mA
IddPdn	Current consumption in power-down mode <sup>(2)</sup>			20		μA
Sc	Short-circuit current		1		10	mA
AOP	Acoustic overload point			120		dB SPL
So	Sensitivity		-29	-26	-23	dB FS
SNR	Signal-to-noise ratio	A-weighted at 1 kHz, 1 Pa		63		dB
PSR	Power supply rejection	Guaranteed by design		-70		dB FS
Clock	Input clock frequency <sup>(3)</sup>		1	2.4	3.25	MHz
Ton	Turn-on time <sup>(4)</sup>	Guaranteed by design			10	ms
Top	Operating temperature range		-40		+85	°C
V <sub>IOL</sub>	Low-level logic input/output voltage	I <sub>out</sub> = 1 mA	-0.3		0.35xVdd	V
V <sub>IOH</sub>	High-level logic input/output voltage	I <sub>out</sub> = 1 mA	0.65xVdd		Vdd+0.3	V

**Notes:**

<sup>(1)</sup>Typical specifications are not guaranteed.

<sup>(2)</sup>Input clock in static mode.

<sup>(3)</sup>Duty cycle: min = 40% max = 60%.

<sup>(4)</sup>Time from the first clock edge to valid output data.

**Table 4: Distortion specifications**

Parameter	Test condition	Value
Distortion	100 dB SPL (50 Hz - 4 kHz)	< 1% THD + N
Distortion	115 dB SPL (1 kHz)	< 5% THD + N

## 2.2 Timing characteristics

Table 5: Timing characteristics

Parameter	Description	Min.	Max.	Unit
$f_{CLK}$	Clock frequency for normal mode	1	3.25	MHz
$f_{PD}$	Clock frequency for power-down mode		0.23	MHz
$T_{CLK}$	Clock period for normal mode	308	1000	ns
$T_{R,EN}$	Data enabled on DATA line, L/R pin = 1	18 <sup>(1)</sup>		ns
$T_{R,DIS}$	Data disabled on DATA line, L/R pin = 1		16 <sup>(1)</sup>	ns
$T_{L,EN}$	Data enabled on DATA line, L/R pin = 0	18 <sup>(1)</sup>		ns
$T_{L,DIS}$	Data disabled on DATA line, L/R pin = 0		16 <sup>(1)</sup>	ns

**Notes:**

<sup>(1)</sup>From design simulations

Figure 2: Timing waveforms

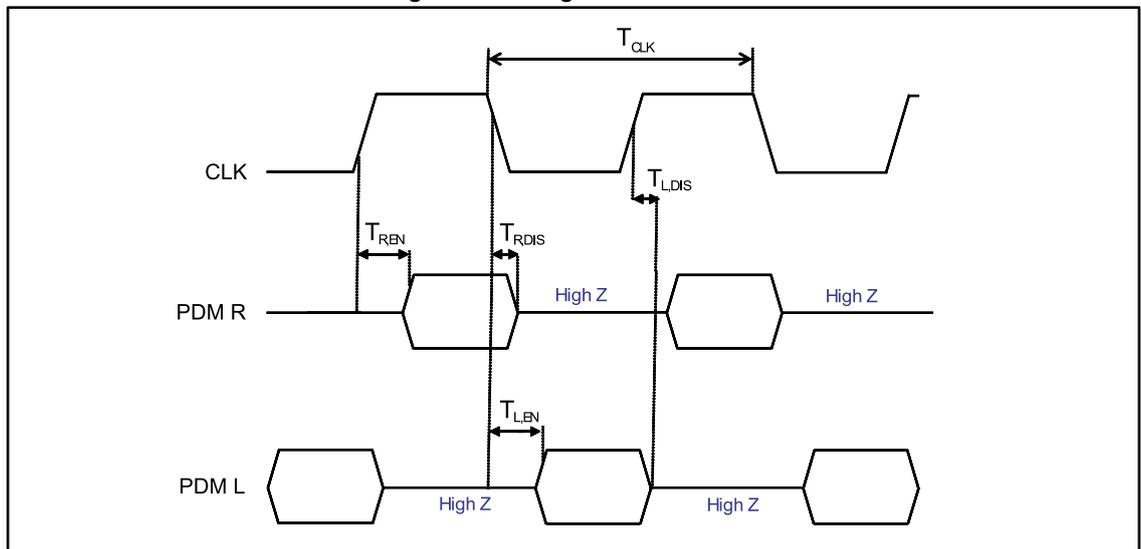

## 2.3 Frequency response

Figure 3: Frequency response and mask

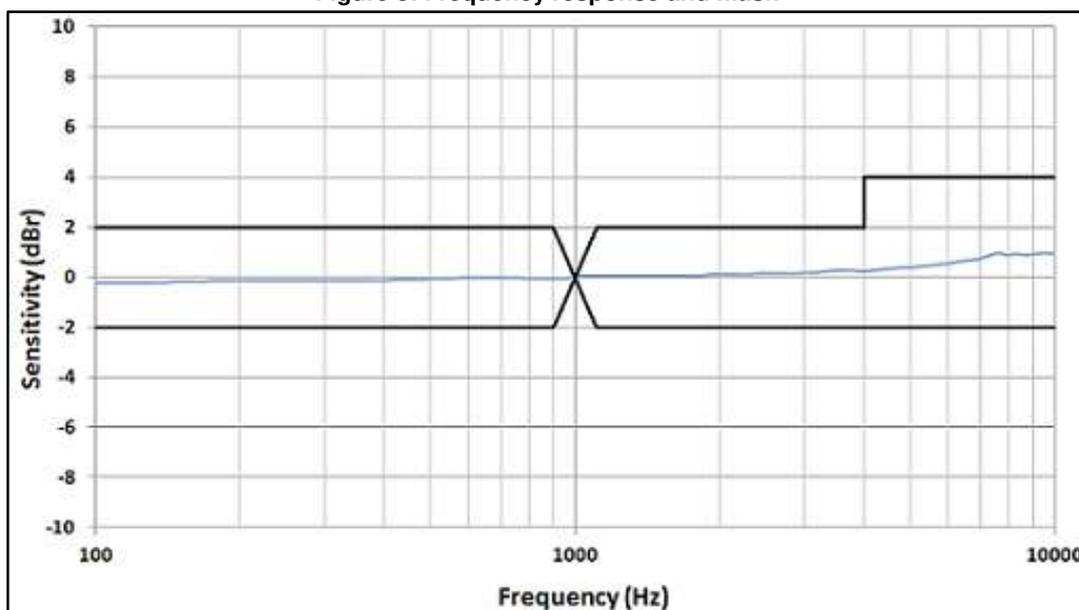

Table 6: Frequency response mask for digital microphones

Frequency / Hz <sup>(1)</sup>	Lower limit	Upper limit	Unit
100...4000	-2	+2	dBr 1 kHz
4000...10000	-2	+4	dBr 1 kHz

**Notes:**

<sup>(1)</sup>At T = 20 °C and acoustic stimulus = 1 Pa (94 dB SPL)



## 4 Process recommendations

To ensure a consistent manufacturing process it is strongly advised to comply with the following recommendations:

- The recommended pick-up area for the MP34DT01 package must be defined using the worst case (ie. no device alignment during the picking process). This area has been defined considering all the tolerances of the components involved (reel, package, sound inlet). The picker tolerance shall be considered as well.
- To prevent damage to the MEMS membrane or incorrect pick-up and placement, do not pick up the component on the inlet area
- For the package outline please refer to [Figure 5: "Carrier tape with microphone \(top view\)"](#). Nozzle shape, size, and placement accuracy are the other key factors to consider when deciding on the coordinates for picking.
- Device alignment before picking is highly recommended.
- A vacuum force greater than 7 psi must be avoided
- 1 kPa = 0.145 psi (lb/in<sup>2</sup>) = 0.0102 kgf/cm<sup>2</sup> = 0.0098 atm
- All recommended dimensions (device safe-picking area) do not include the pick-and-place equipment tolerances

Figure 6: Recommended picking area

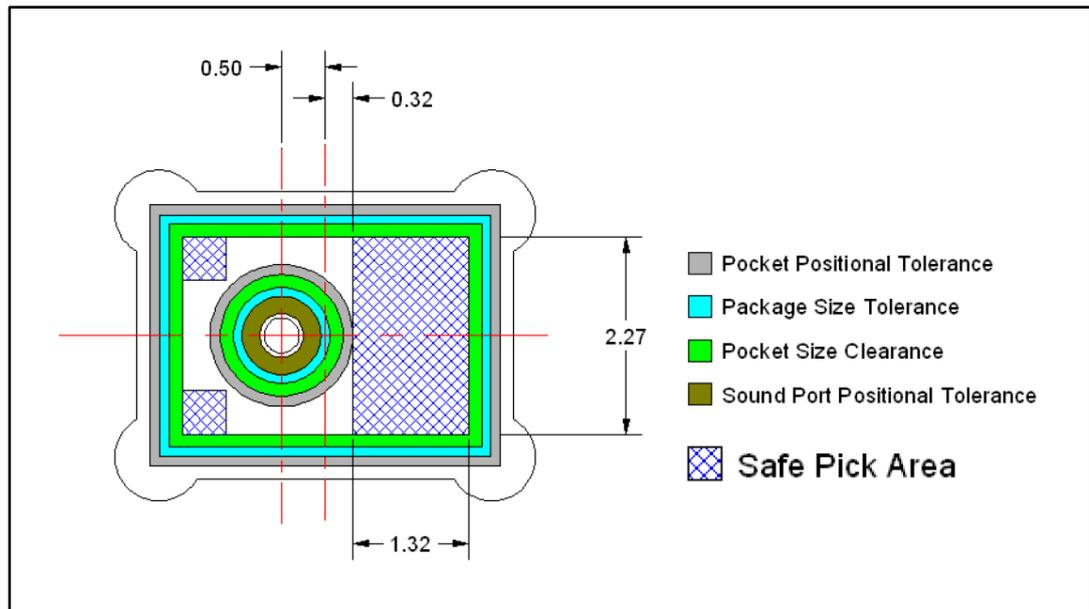

To have a safe pick-up "by design", ST strongly advises an ad hoc nozzle.

The following picker ensures that the holes for the vacuum and the air stream are ALWAYS away from the porthole of the device (4 vacuum ports located at each corner of the device).

The recommended nozzle also has a recess, in the form of a cross, which guarantees that the porthole is always left at atmospheric pressure. By using the recommended nozzle, the membrane will not suffer any sudden air disturbances during the picking or placing of the devices in the tape and reel.

Figure 7: Recommended picker design

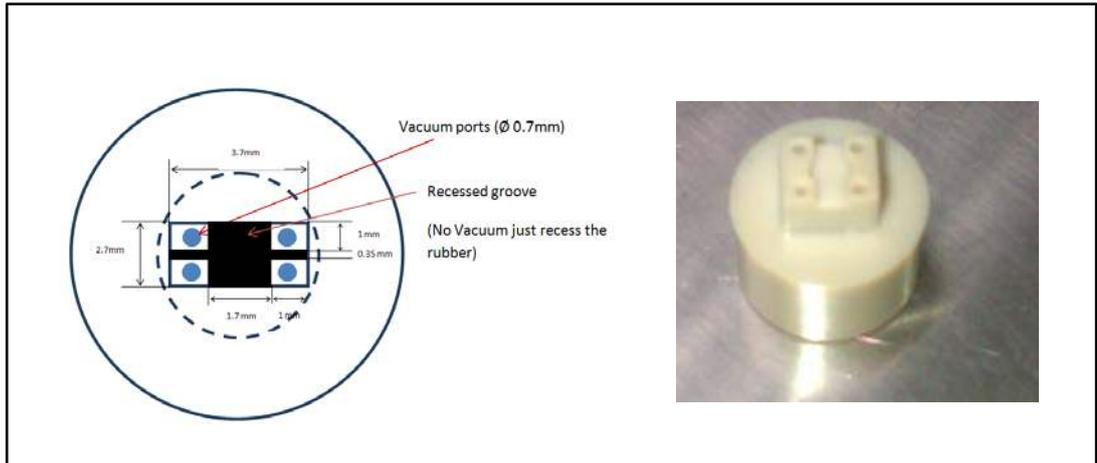

## 5 Sensing element

The sensing element shall mean the acoustic sensor consisting of a conductive movable plate and a fixed plate placed in a tiny silicon chip. This sensor transduces the sound pressure into the changes of coupled capacity between those two plates.

Omron Corporation supplies this element for STMicroelectronics.

## 6 Absolute maximum ratings

Stresses above those listed as “absolute maximum ratings” may cause permanent damage to the device. This is a stress rating only and functional operation of the device under these conditions is not implied. Exposure to maximum rating conditions for extended periods may affect device reliability.

**Table 7: Absolute maximum ratings**

Symbol	Ratings	Maximum value	Unit
V <sub>dd</sub>	Supply voltage	-0.3 to 6	V
V <sub>in</sub>	Input voltage on any control pin	-0.3 to V <sub>dd</sub> +0.3	V
T <sub>STG</sub>	Storage temperature range	-40 to +125	°C
ESD	Electrostatic discharge protection	2 (HBM)	kV



This device is sensitive to mechanical shock, improper handling can cause permanent damage to the part.



This device is sensitive to electrostatic discharge (ESD), improper handling can cause permanent damage to the part.

## 7 Functionality

### 7.1 L/R channel selection

The L/R digital pad lets the user select the DOUT signal pattern as shown in [Table 8: "L/R channel selection"](#). The L/R pin must be connected to Vdd or GND.

**Table 8: L/R channel selection**

L/R	CLK low	CLK high
GND	Data valid	High impedance
Vdd	High impedance	Data valid

## 8 Package information

In order to meet environmental requirements, ST offers these devices in different grades of ECOPACK® packages, depending on their level of environmental compliance. ECOPACK® specifications, grade definitions and product status are available at: [www.st.com](http://www.st.com). ECOPACK® is an ST trademark.

### 8.1 Soldering information

The HCLGA (3 x 4) 4LD package is also compliant with the RoHS and “Green” standards and is qualified for soldering heat resistance according to JEDEC J-STD-020.

Land pattern and soldering recommendations are available at [www.st.com](http://www.st.com).

Figure 8: Recommended soldering profile limits

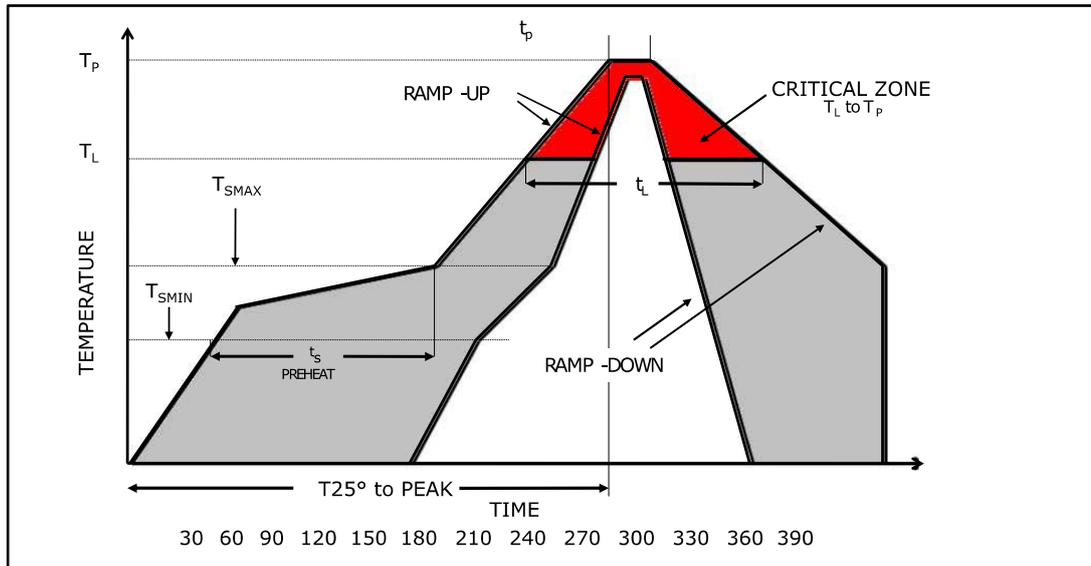
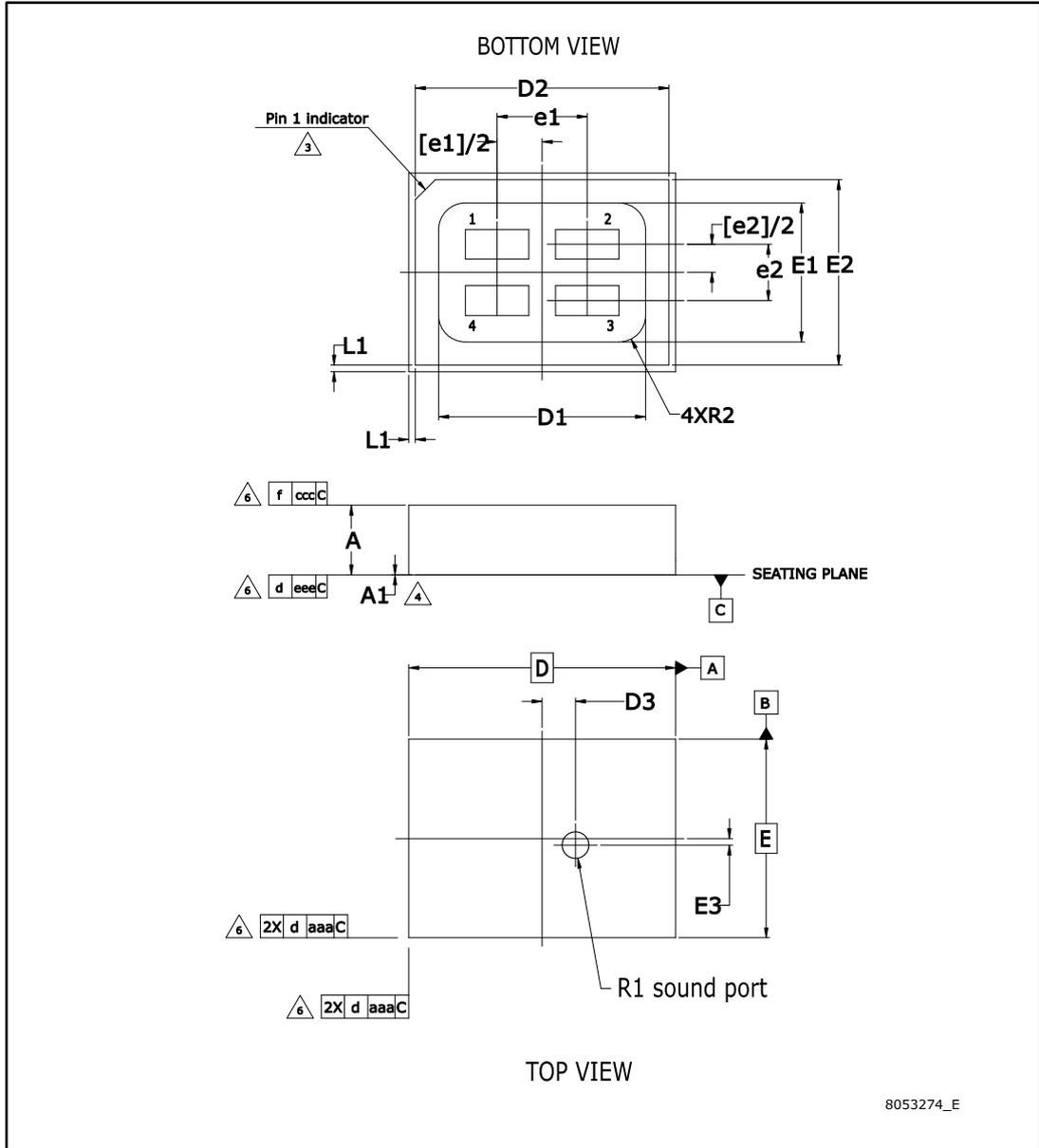

Table 9: Recommended soldering profile limits

Description	Parameter	Pb free
Average ramp rate	$T_L$ to $T_P$	3 °C/sec max
Preheat		
Minimum temperature	$T_{SMIN}$	150 °C
Maximum temperature	$T_{SMAX}$	200 °C
Time ( $T_{SMIN}$ to $T_{SMAX}$ )	$t_s$	60 sec to 120 sec
Ramp-up rate	$T_{SMAX}$ to $T_L$	
Time maintained above liquids temperature	$t_L$	60 sec to 150 sec
Liquids temperature	$T_L$	217 °C
Peak temperature	$T_P$	260 °C max
Time within 5 °C of actual peak temperature		20 sec to 40 sec
Ramp-down rate		6 °C/sec max
Time 25 °C ( $t_{25}$ °C) to peak temperature		8 minutes max

## 8.2 HCLGA package information

Figure 9: HCLGA (3 x 4 x 1 mm) 4-lead package outline



Note: The MEMS microphone plastic cap can exhibit some level of variation in color when the device is subjected to thermal processes.

Table 10: HCLGA (3 x 4 x 1 mm) 4-lead package dimensions

Symbol	mm		
	Min.	Typ.	Max.
A	0.90	1.00	1.10
A1	0.00	-	0.05
b	0.35	0.45	0.50
D	3.90	4.00	4.10
D1	3.05	3.10	3.15
D2	3.75	3.80	3.85
D3	0.30	0.50	0.70
E	2.90	3.00	3.10
E1	2.05	2.10	2.15
E2	2.75	2.80	2.85
E3	-0.20	0.00	0.20
e1	1.30	1.35	1.40
e2	0.80	0.85	0.90
h	0.25	0.30	0.35
L	0.90	0.95	1.00
L1	-	0.10	-
N	4		
R1	0.30	0.40	0.50
R2	-	0.40	-
aaa	0.15		
ccc	0.10		
eee	0.08		

Figure 10: Land pattern

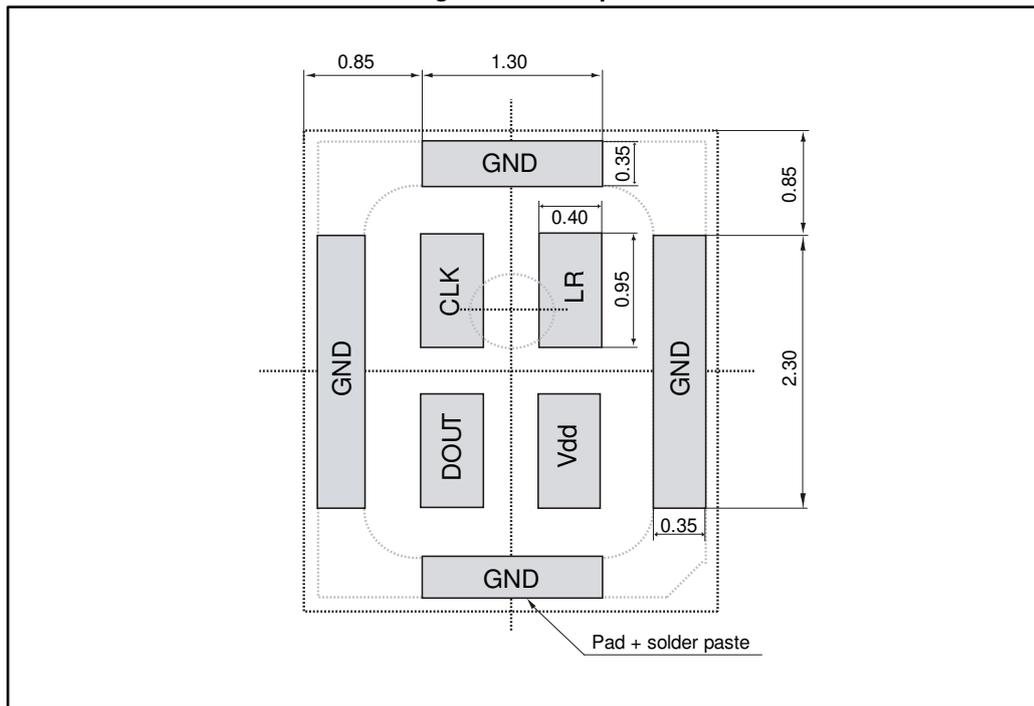

## 9 Revision history

Table 11: Document revision history

Date	Revision	Changes
06-Oct-2011	1	Initial release
18-Nov-2011	2	Removed "stereo" from title, <i>Section "Features"</i> , and <i>Section "Description"</i>
29-Nov-2011	3	Updated <i>Section "Features"</i> and <i>Section "Description"</i>
04-Jan-2012	4	Updated Added So limits to <i>Table 3: "Acoustic and electrical characteristics"</i> Minor textual updates
23-Mar-2012	5	Updated <i>Figure 9: "HCLGA (3 x 4 x 1 mm) 4-lead package outline"</i> Pin 1 indicator removed from top view of package on page 1 and <i>Figure 1: "Pin connections"</i> Updated <i>Table 10: "HCLGA (3 x 4 x 1 mm) 4-lead package dimensions"</i>
06-Apr-2012	6	Updated maximum supply voltage in <i>Table 3: "Acoustic and electrical characteristics"</i>
07-May-2012	7	Added $V_{IOL}$ , $V_{IOH}$ to <i>Table 3: "Acoustic and electrical characteristics"</i>
18-May-2012	8	Updated <i>Table 5: "Timing characteristics"</i>
05-Jul-2012	9	Added <i>Section 5: "Sensing element"</i> Added <i>Figure 10: "Land pattern"</i> Updated temperature range to -40 to +85 °C throughout datasheet
21-Feb-2013	10	Updated dimension T2 in <i>Table 10: "HCLGA (3 x 4 x 1 mm) 4-lead package dimensions"</i>
07-Jun-2013	11	Updated - <i>Figure 3: "Frequency response and mask"</i> - <i>Table 6: "Frequency response mask for digital microphones"</i> - HCLGA mechanical data <i>Figure 9: "HCLGA (3 x 4 x 1 mm) 4-lead package outline"</i> and <i>Table 10: "HCLGA (3 x 4 x 1 mm) 4-lead package dimensions"</i> Added - <i>Section 3: "Carrier tape mechanical specifications"</i> - <i>Section 4: "Process recommendations"</i>
27-Feb-2015	12	Minor textual updates Added note below <i>Figure 9: "HCLGA (3 x 4 x 1 mm) 4-lead package outline"</i>

**IMPORTANT NOTICE – PLEASE READ CAREFULLY**

STMicroelectronics NV and its subsidiaries ("ST") reserve the right to make changes, corrections, enhancements, modifications, and improvements to ST products and/or to this document at any time without notice. Purchasers should obtain the latest relevant information on ST products before placing orders. ST products are sold pursuant to ST's terms and conditions of sale in place at the time of order acknowledgement.

Purchasers are solely responsible for the choice, selection, and use of ST products and ST assumes no liability for application assistance or the design of Purchasers' products.

No license, express or implied, to any intellectual property right is granted by ST herein.

Resale of ST products with provisions different from the information set forth herein shall void any warranty granted by ST for such product.

ST and the ST logo are trademarks of ST. All other product or service names are the property of their respective owners.

Information in this document supersedes and replaces information previously supplied in any prior versions of this document.

© 2015 STMicroelectronics – All rights reserved