

REVISIONS					
P	LTR	DESCRIPTION	DATE	DMN	APVD
AB	REV PER ECO	17-000132	5-5-17	CT	DM

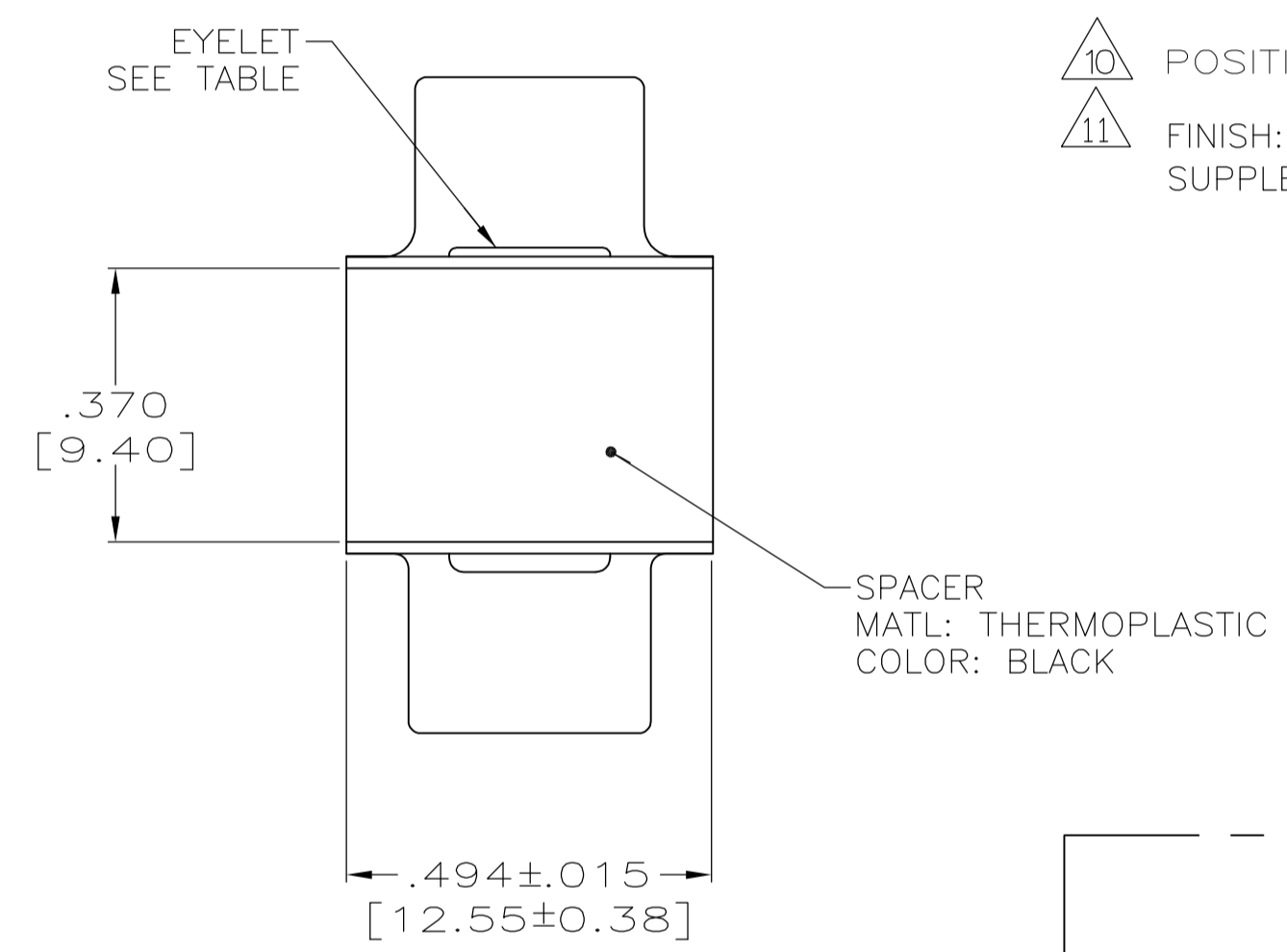

- CONTACTS INCLUDED IN ASSEMBLY.
- MATL: STEEL, PER ASTM-A-109.
- FINISH: CADMIUM PER QQ-P-416.
- MATL: BRASS PER ASTM-B-36.
- FINISH: PLATED ZINC .00020 MIN THK PER ASTM-B-633. YELLOW CHROMATE FINISH.
- CONTACT  
 BODY MAT'L: BERYLLIUM COPPER PER ASTM-B-197.  
 BODY FINISH: PLATED GOLD, .000050 MIN THK PER MIL-G-45204 OVER NICKEL, .000050 MIN THK PER QQ-N-290.  
 HOOD MAT'L: STAINLESS STEEL PER ASTM-A-240.  
 HOOD FINISH: PASSIVATED PER QQ-P-35
- FINISH: PLATED GOLD, .000050 MIN THK PER MIL-G-45204 OVER COPPER FLASH
- FINISH: PLATED GOLD, .000050 MIN THK PER MIL-G-45204 OVER COPPER, .000100 MIN THK PER MIL-C-14550.
- CONTACT  
 BODY MAT'L: BERYLLIUM COPPER PER ASTM-B-197.  
 BODY FINISH: PLATED GOLD, .000050 MIN THK PER MIL-G-45204 OVER COPPER, .000100 MIN THK PER MIL-C-14550.
- HOOD MAT'L: COPPER ALLOY PER QQ-B-613.  
 FINISH: PLATED GOLD, .000050 MIN THK PER MIL-G-45204 OVER COPPER, .000100 MIN THK PER MIL-C-14550.
- POSITIONS 37 & 38 DO NOT HAVE A CONTACT OR CLIP LOADED.
- FINISH: PLATED ZINC PER ASTM-B-633 .000200 MIN THK WITH SUPPLEMENTARY CHROMATE (Cr3+).

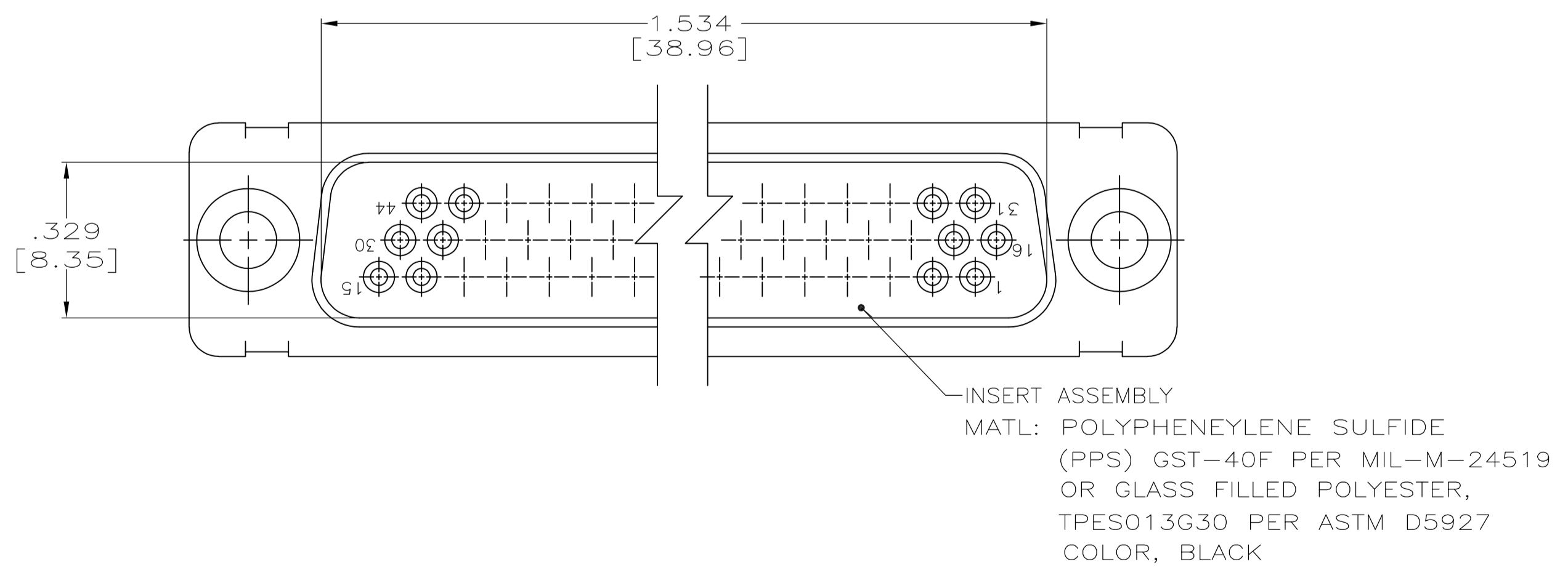
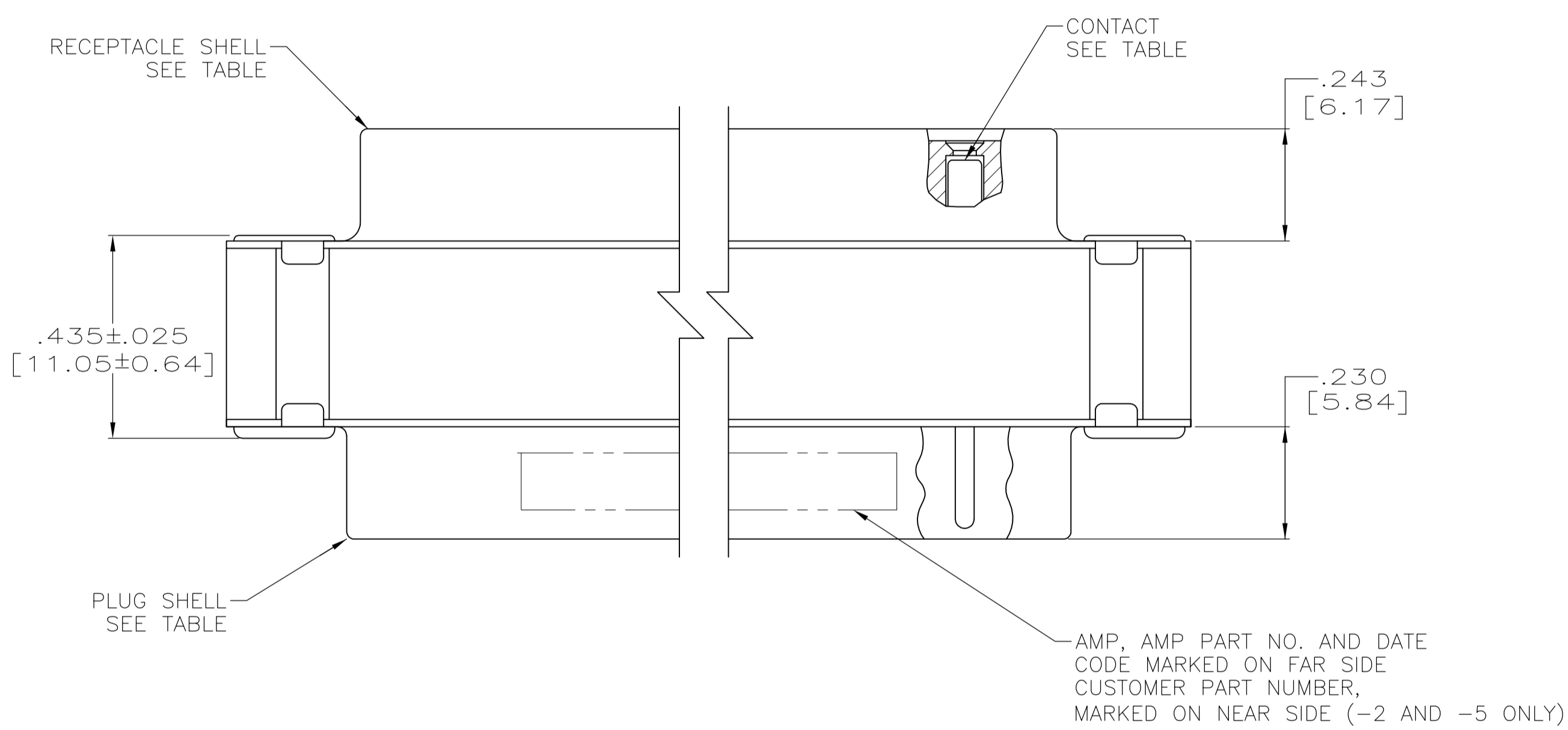
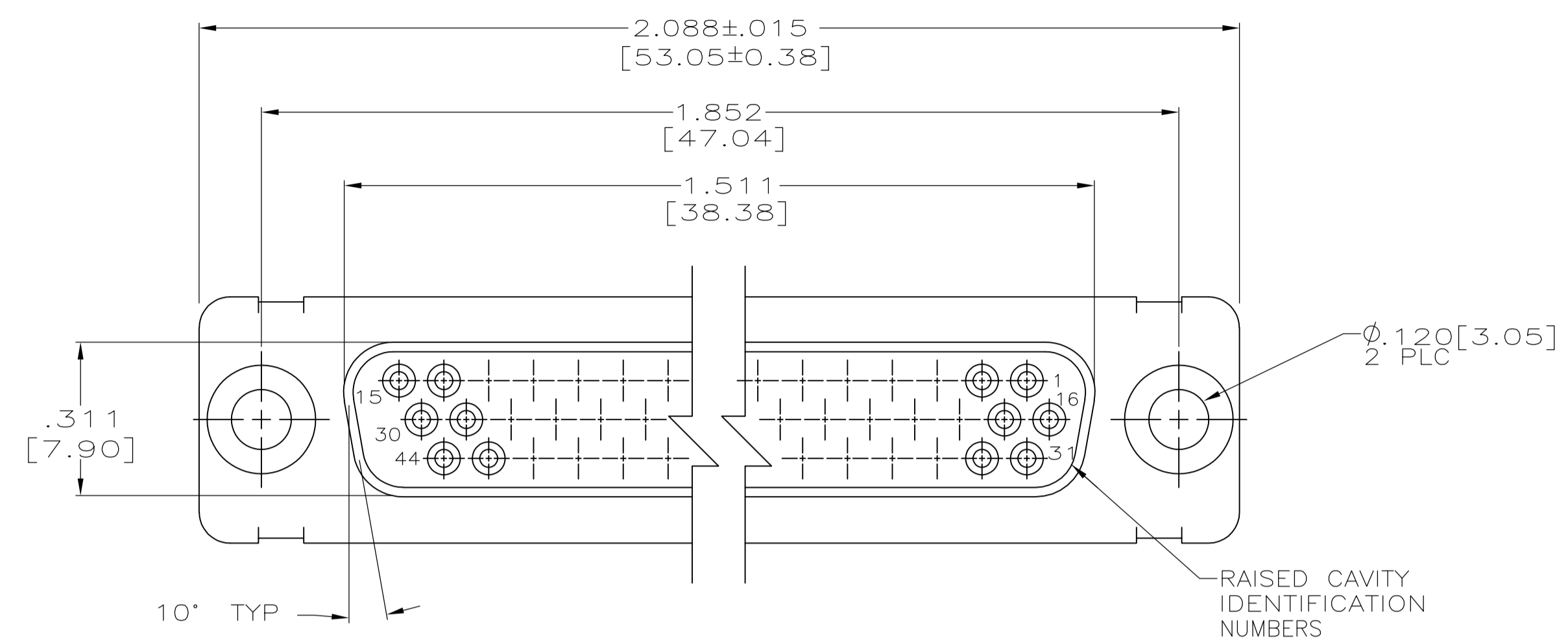
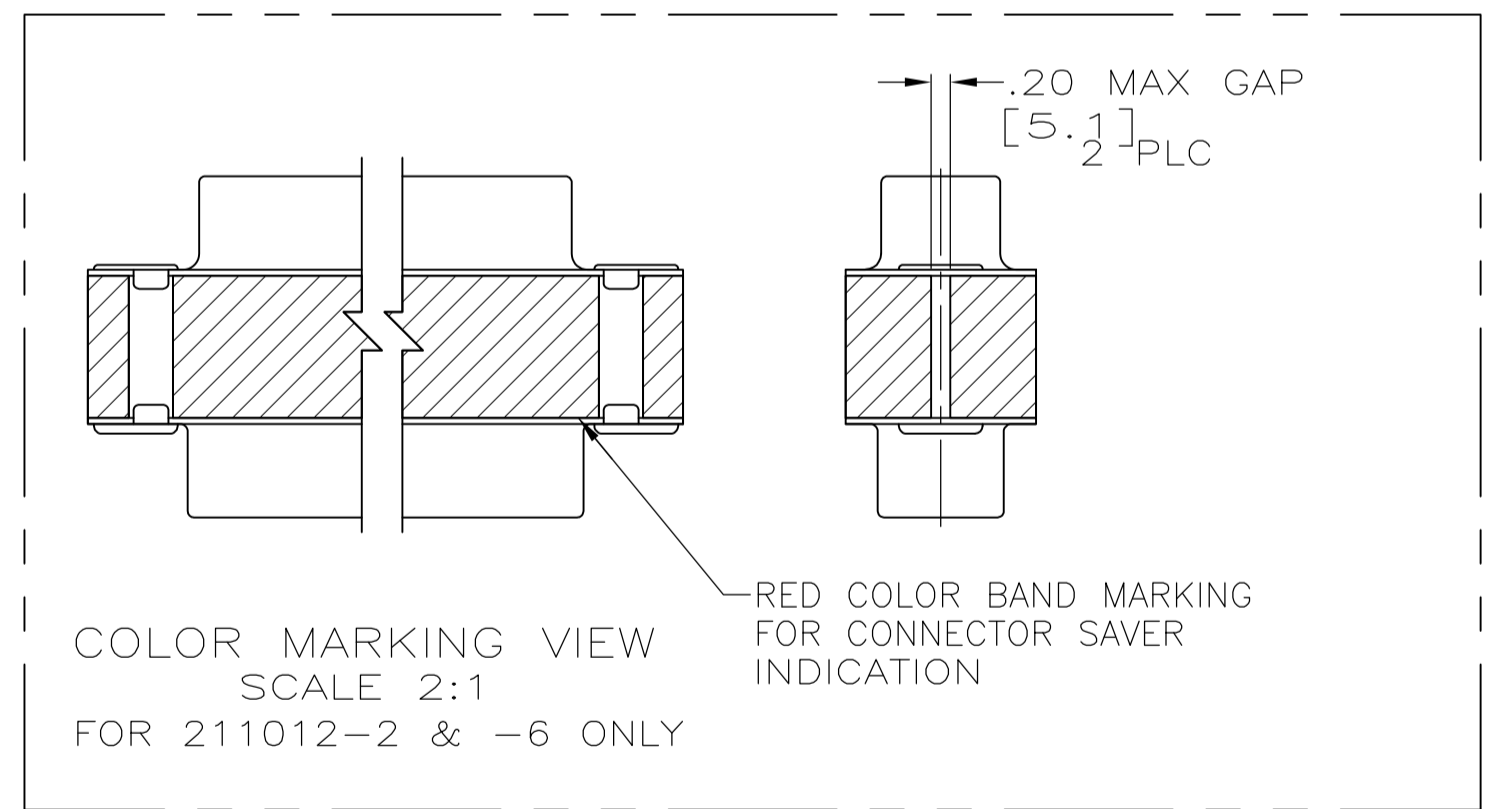

OBSOLETE

△10	△4 △11	△11	△6	-	5-211012-7
△10	△4 △5	△3	△6	-	211012-7
-	△4 △8	△4	△6	4U884 SOCN R10002677-0108	211012-6
-	△4 △8	△4	△6	2A091-003W-001	211012-5
-	△4 △8	△4	△6	-	211012-4
-	△4 △8	△4	△6	-	211012-3
-	△4 △8	△4	△6	(1J02-108)	211012-2
-	△4 △8	△4	△6	-	211012-1
CONTACT	EYELET	SHELLS	CONTACT	CUSTOMER P/N	PART NO.

THIS DRAWING IS A CONTROLLED DOCUMENT. DIMENSIONS: INCHES. TOLERANCES UNLESS OTHERWISE SPECIFIED: 0 PLC ± .005, 1 PLC ± .005, 2 PLC ± .005, 3 PLC ± .005, 4 PLC ± .005. MATERIAL: -. FINISH: -. THIS DRAWING IS UNPUBLISHED. RELEASED FOR PUBLICATION. ALL RIGHTS RESERVED. C.C. THOMAS 11-3-98. J. NORTON 11-17-98. J. NORTON 11-17-98. NAME: CONNECTOR SAVER, AMPLIMITE 44 POSN, SIZE 3, SERIES 90. SIZE: A1. CAGE CODE: 00779. DRAWING NO: 211012. WEIGHT: 0.000000. RESTRICTED TO: -. CUSTOMER DRAWING. SCALE: 4:1. SHEET: 1 OF 1. REV: AB.