



# 3470 MHz Ceramic Bandpass Filter for WLL

**ANATECH ELECTRONICS INC**  
RF & Microwave Filters & Products

**Part Number: AM3470B118**



## Electrical specifications

**Center Frequency:** 3470 MHz  
**Bandwidth:** +/- 65.0 MHz  
**VSWR:** 2.0 max  
**Input / Output Impedance:** 50 Ohms  
**Passband:** 3437.5-3502.5 MHz  
**Passband Insertion Loss:** 1.15 dB  
**Passband Ripple:** 0.26 dB  
**Rejection:** 2000-2800 MHz 30 dB min  
**Rejection 2:** 3050-3200 MHz 26 dB min  
**Rejection 3:** 3900-4500 MHz 30 dB min  
**Power Handling:** 1 W

## Mechanical

**Mounting Method:** SMT  
**Dimensions:** 9 x 5.75 x 3 mm

## Environmental

**Operating Temperature:** -40°C to 85°C  
**Storage Temperature:** -50°C to +90°C

**This product is RoHs compliant.**

## Outline Drawing:

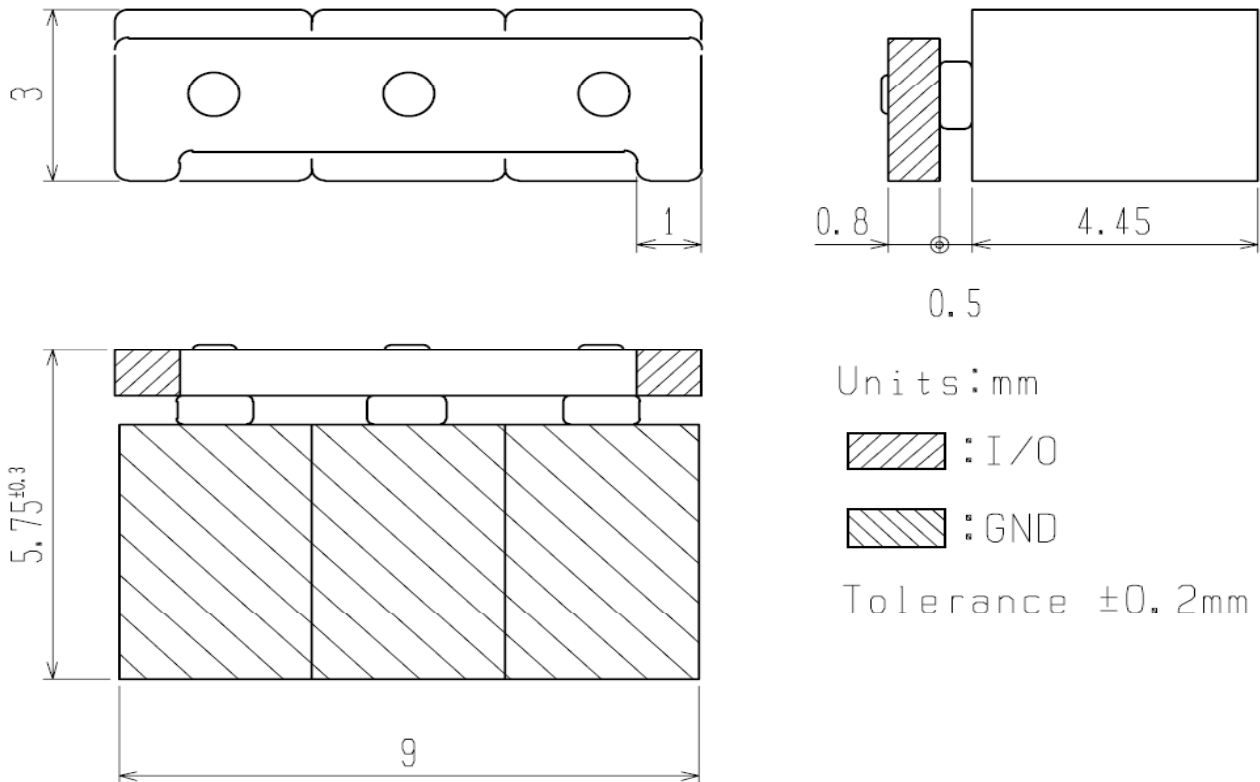

## Outside dimensions



# 3470 MHz Ceramic Bandpass Filter for WLL

**ANATECH ELECTRONICS INC**  
RF & Microwave Filters & Products

**Part Number: AM3470B118**



## Response Plot:

