

# High Voltage Transistors

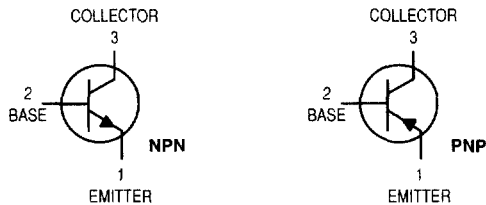

**NPN**  
**2N6515**  
**2N6517**  
**PNP**  
**2N6519**  
**2N6520**

Voltage and current are negative for PNP transistors

## MAXIMUM RATINGS

Rating	Symbol	2N6515	2N6519	2N6517 2N6520	Unit
Collector-Emitter Voltage	$V_{CEO}$	250	300	350	Vdc
Collector-Base Voltage	$V_{CBO}$	250	300	350	Vdc
Emitter-Base Voltage 2N6515, 2N6516, 2N6517 2N6519, 2N6520	$V_{EBO}$		6.0 5.0		Vdc
Base Current	$I_B$		250		mAdc
Collector Current — Continuous	$I_C$		500		mAdc
Total Device Dissipation @ $T_A = 25^\circ\text{C}$ Derate above $25^\circ\text{C}$	$P_D$		625 5.0		mW mW/ $^\circ\text{C}$
Total Device Dissipation @ $T_C = 25^\circ\text{C}$ Derate above $25^\circ\text{C}$	$P_D$		1.5 12		Watts mW/ $^\circ\text{C}$
Operating and Storage Junction Temperature Range	$T_J, T_{stg}$		-55 to +150		$^\circ\text{C}$



CASE 29-04, STYLE 1  
TO-92 (TO-226AA)

## THERMAL CHARACTERISTICS

Characteristic	Symbol	Max	Unit
Thermal Resistance, Junction to Ambient	$R_{\theta JA}$	200	$^\circ\text{C/W}$
Thermal Resistance, Junction to Case	$R_{\theta JC}$	83.3	$^\circ\text{C/W}$

## ELECTRICAL CHARACTERISTICS ( $T_A = 25^\circ\text{C}$ unless otherwise noted)

Characteristic	Symbol	Min	Max	Unit
----------------	--------	-----	-----	------

## OFF CHARACTERISTICS

Collector-Emitter Breakdown Voltage <sup>(1)</sup> ( $I_C = 1.0 \text{ mAdc}, I_B = 0$ )	2N6515 2N6519 2N6517, 2N6520	$V_{(BR)CEO}$	250 300 350	— — —	Vdc
Collector-Base Breakdown Voltage ( $I_C = 100 \mu\text{Adc}, I_E = 0$ )	2N6515 2N6519 2N6517, 2N6520	$V_{(BR)CBO}$	250 300 350	— — —	Vdc
Emitter-Base Breakdown Voltage ( $I_E = 10 \mu\text{Adc}, I_C = 0$ )	2N6515, 2N6517 2N6519, 2N6520	$V_{(BR)EBO}$	6.0 5.0	— —	Vdc

1. Pulse Test: Pulse Width  $\leq 300 \mu\text{s}$ , Duty Cycle  $\leq 2.0\%$ .

# NPN 2N6515 2N6517 PNP 2N6519 2N6520

## ELECTRICAL CHARACTERISTICS (T<sub>A</sub> = 25°C unless otherwise noted) (Continued)

Characteristic	Symbol	Min	Max	Unit
<b>OFF CHARACTERISTICS (Continued)</b>				
Collector Cutoff Current (V <sub>CB</sub> = 150 Vdc, I <sub>E</sub> = 0) (V <sub>CB</sub> = 200 Vdc, I <sub>E</sub> = 0) (V <sub>CB</sub> = 250 Vdc, I <sub>E</sub> = 0)	I <sub>CBO</sub>	—	50	nAdc
		—	50	
		—	50	
Emitter Cutoff Current (V <sub>EB</sub> = 5.0 Vdc, I <sub>C</sub> = 0) (V <sub>EB</sub> = 4.0 Vdc, I <sub>C</sub> = 0)	I <sub>EBO</sub>	—	50	nAdc
		—	50	

## ON CHARACTERISTICS(1)

DC Current Gain (I <sub>C</sub> = 1.0 mAdc, V <sub>CE</sub> = 10 Vdc)	h <sub>FE</sub>	35	—	—
		30	—	
		20	—	
(I <sub>C</sub> = 10 mAdc, V <sub>CE</sub> = 10 Vdc)		50	—	
		45	—	
		30	—	
(I <sub>C</sub> = 30 mAdc, V <sub>CE</sub> = 10 Vdc)		50	300	
		45	270	
		30	200	
(I <sub>C</sub> = 50 mAdc, V <sub>CE</sub> = 10 Vdc)		45	220	
		40	200	
		20	200	
(I <sub>C</sub> = 100 mAdc, V <sub>CE</sub> = 10 Vdc)		25	—	
		20	—	
		15	—	
Collector–Emitter Saturation Voltage (I <sub>C</sub> = 10 mAdc, I <sub>B</sub> = 1.0 mAdc) (I <sub>C</sub> = 20 mAdc, I <sub>B</sub> = 2.0 mAdc) (I <sub>C</sub> = 30 mAdc, I <sub>B</sub> = 3.0 mAdc) (I <sub>C</sub> = 50 mAdc, I <sub>B</sub> = 5.0 mAdc)	V <sub>CE(sat)</sub>	—	0.30	Vdc
		—	0.35	
		—	0.50	
		—	1.0	
Base–Emitter Saturation Voltage (I <sub>C</sub> = 10 mAdc, I <sub>B</sub> = 1.0 mAdc) (I <sub>C</sub> = 20 mAdc, I <sub>B</sub> = 2.0 mAdc) (I <sub>C</sub> = 30 mAdc, I <sub>B</sub> = 3.0 mAdc)	V <sub>BE(sat)</sub>	—	0.75	Vdc
		—	0.85	
		—	0.90	
Base–Emitter On Voltage (I <sub>C</sub> = 100 mAdc, V <sub>CE</sub> = 10 Vdc)	V <sub>BE(on)</sub>	—	2.0	Vdc

## SMALL-SIGNAL CHARACTERISTICS

Current–Gain — Bandwidth Product(1) (I <sub>C</sub> = 10 mAdc, V <sub>CE</sub> = 20 Vdc, f = 20 MHz)	f <sub>T</sub>	40	200	MHz
Collector–Base Capacitance (V <sub>CB</sub> = 20 Vdc, I <sub>E</sub> = 0, f = 1.0 MHz)	C <sub>cb</sub>	—	6.0	pF
Emitter–Base Capacitance (V <sub>EB</sub> = 0.5 Vdc, I <sub>C</sub> = 0, f = 1.0 MHz)	C <sub>eb</sub>	—	80	pF
		—	100	

## SWITCHING CHARACTERISTICS

Turn–On Time (V <sub>CC</sub> = 100 Vdc, V <sub>BE(off)</sub> = 2.0 Vdc, I <sub>C</sub> = 50 mAdc, I <sub>B1</sub> = 10 mAdc)	t <sub>on</sub>	—	200	μs
Turn–Off Time (V <sub>CC</sub> = 100 Vdc, I <sub>C</sub> = 50 mAdc, I <sub>B1</sub> = I <sub>B2</sub> = 10 mAdc)	t <sub>off</sub>	—	3.5	μs

1. Pulse Test: Pulse Width ≤ 300 μs, Duty Cycle ≤ 2.0%.

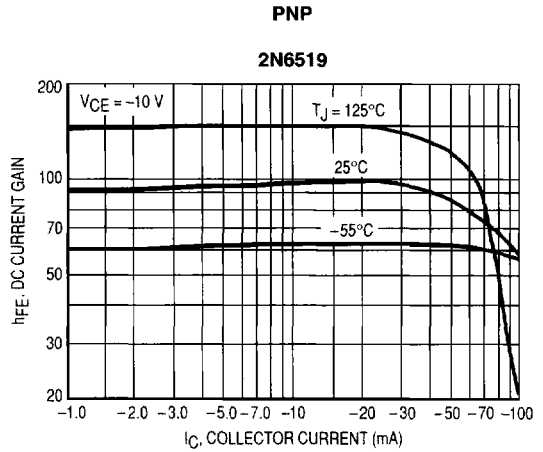
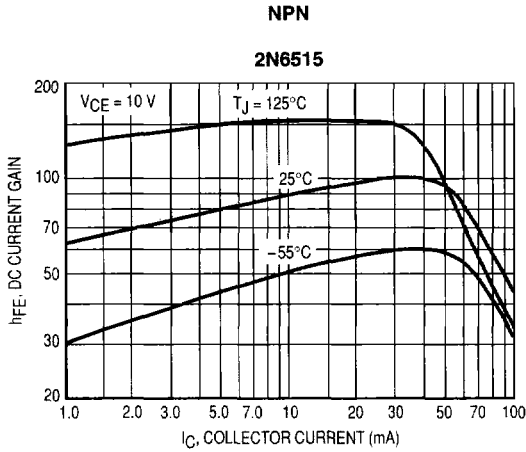

Figure 1. DC Current Gain

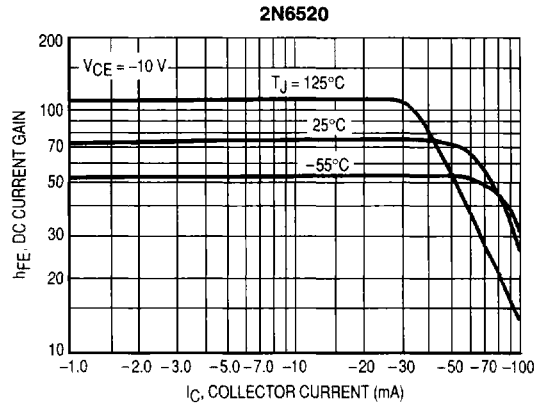
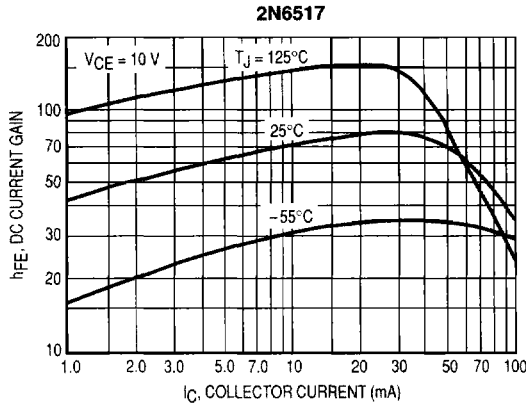

Figure 2. DC Current Gain

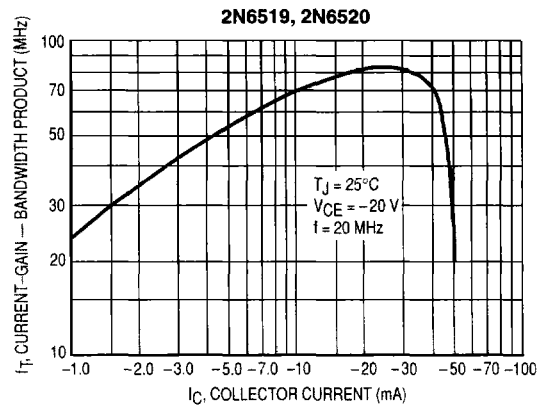
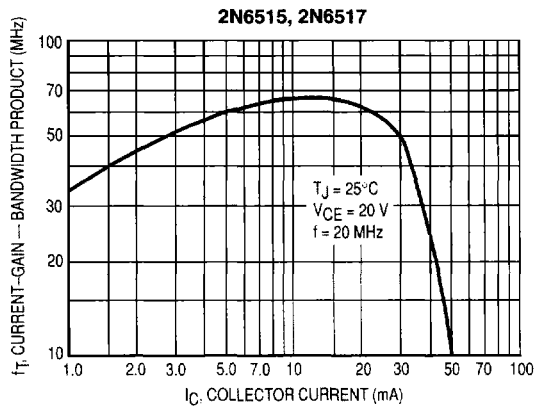
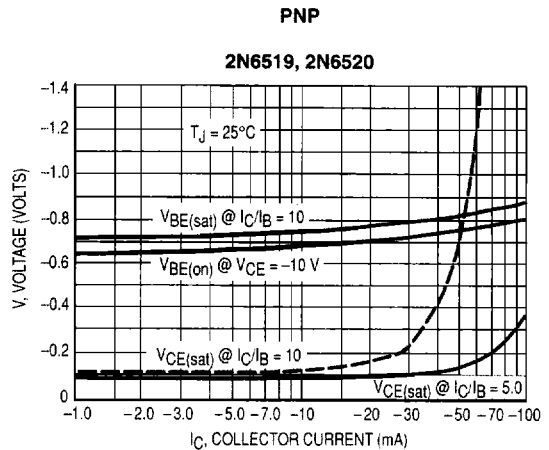
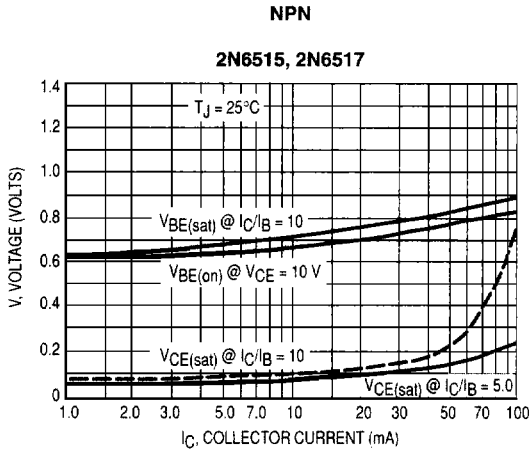
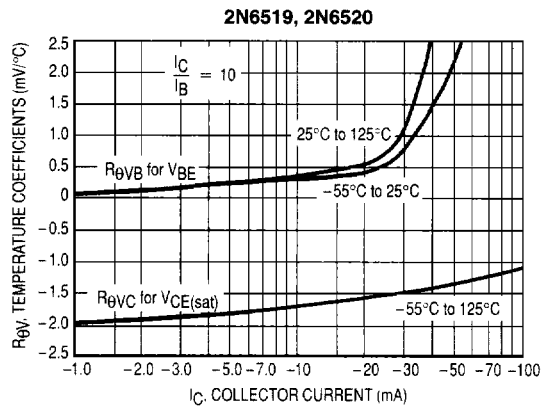
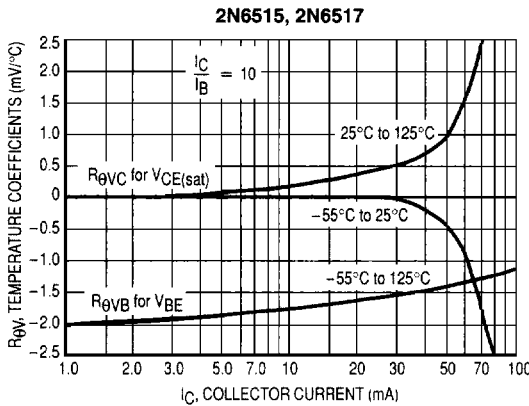

Figure 3. Current-Gain — Bandwidth Product



**Figure 4. "On" Voltages**



**Figure 5. Temperature Coefficients**

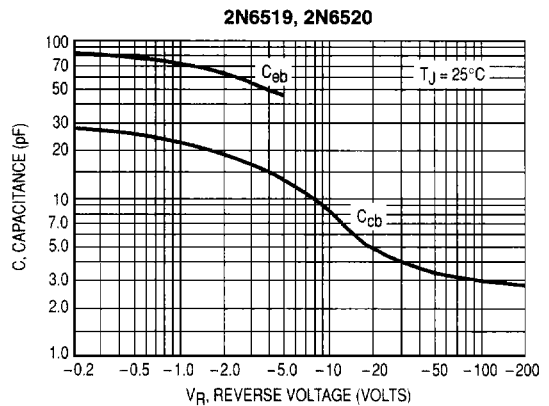
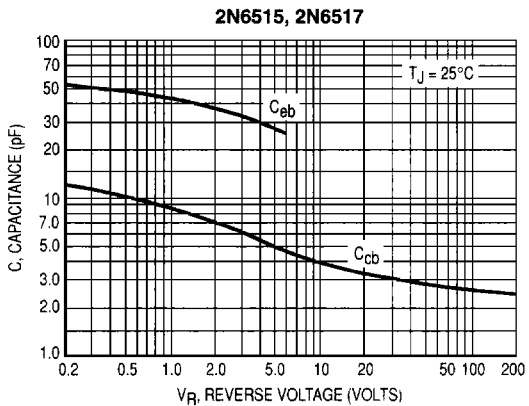

**Figure 6. Capacitance**

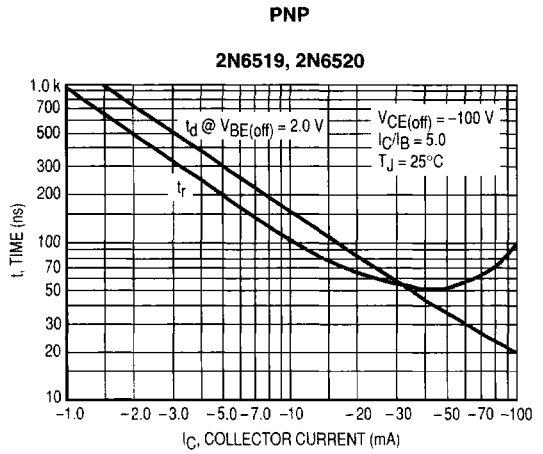
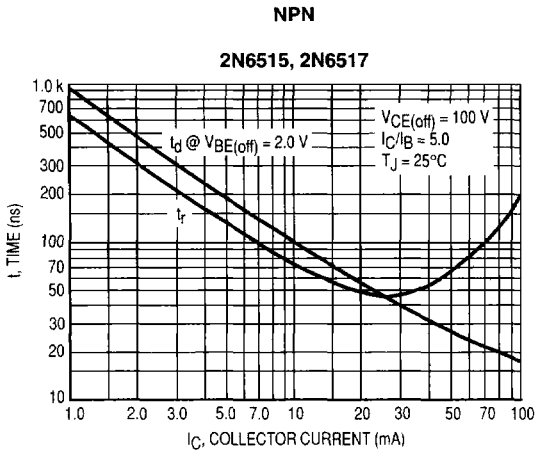

Figure 7. Turn-On Time

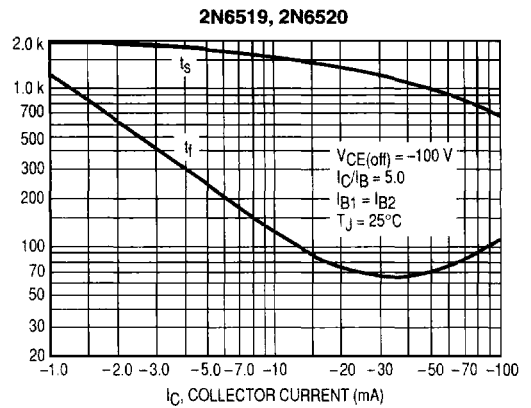
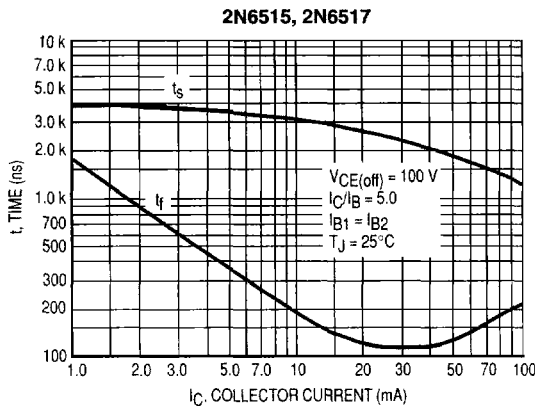
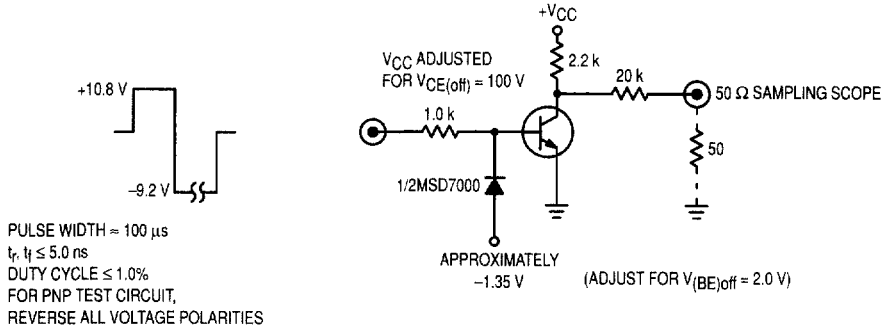
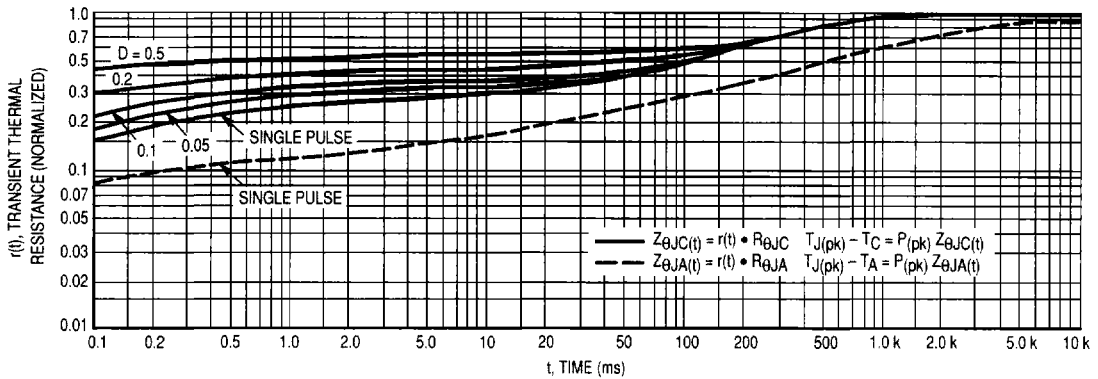

Figure 8. Turn-Off Time



**Figure 9. Switching Time Test Circuit**



**Figure 10. Thermal Response**

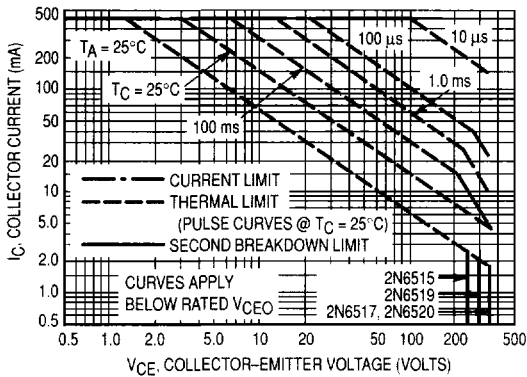

**Figure 11. Active Region Safe Operating Area**

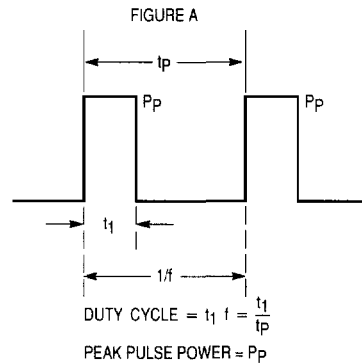

**Design Note: Use of Transient Thermal Resistance Data**