

## PM-108/PM-208/PM-308

### FEATURES

- Low Offset Current ..... 200pA Max
- Low Bias Current ..... 2nA Max
- Low Power Consumption ..... 18mW Max @  $\pm 15V$
- Wide Supply Range .....  $\pm 3V$  to  $\pm 20V$
- High Power-Supply Rejection Ratio ..... 96dB Min
- Low Offset Voltage Drift .....  $5\mu V/^{\circ}C$  Max
- High Common-Mode Input Range .....  $\pm 13.5V$  Min
- High Common-Mode Rejection Ratio ..... 96dB Min
- MIL-STD-883 Processing Models Available
- Silicon-Nitride Passivation

### GENERAL DESCRIPTION

The PM-108A series of precision operational amplifiers feature very low input offset and bias currents. Although directly interchangeable with industry-standard types, Precision Monolithics' advanced processing provides the PM-108A series with a significant improvement in input noise voltage. Low supply current drain over a wide power-supply range makes the PM-108A attractive in battery operated and other low-power applications. The low bias current provides excellent performance with piezoelectric and capacitive transducers and in such high-impedance circuits as long-period integrators and sample-and-holds. For improved performance see OP-08, OP-12, OP-20, OP-21, OP-22, and PM-1008.

### ORDERING INFORMATION

$T_j = +25^{\circ}C$ $V_{OS}$ MAX (mV)	PACKAGE				OPERATING TEMPERATURE RANGE
	TO-99	CERDIP 8-PIN	LCC 28-CONTACT	PLASTIC 8-PIN	
0.5	PM108AJ/883	PM108AZ*	PM108ARC/883	—	MIL COM
0.5	PM308AJ	—	—	PM308AP	—
2.0	PM108J/883	PM108Z*	—	—	MIL IND
2.0	PM208J	PM208Z	—	—	—
7.5	—	PM308Z	—	—	—

\* For devices processed in total compliance to MIL-STD-883, add /883 after part number. Consult factory for 883 data sheet.

† Burn-in is available on commercial and industrial temperature range parts in CerDIP, plastic DIP, and TO-can packages.

### SIMPLIFIED SCHEMATIC

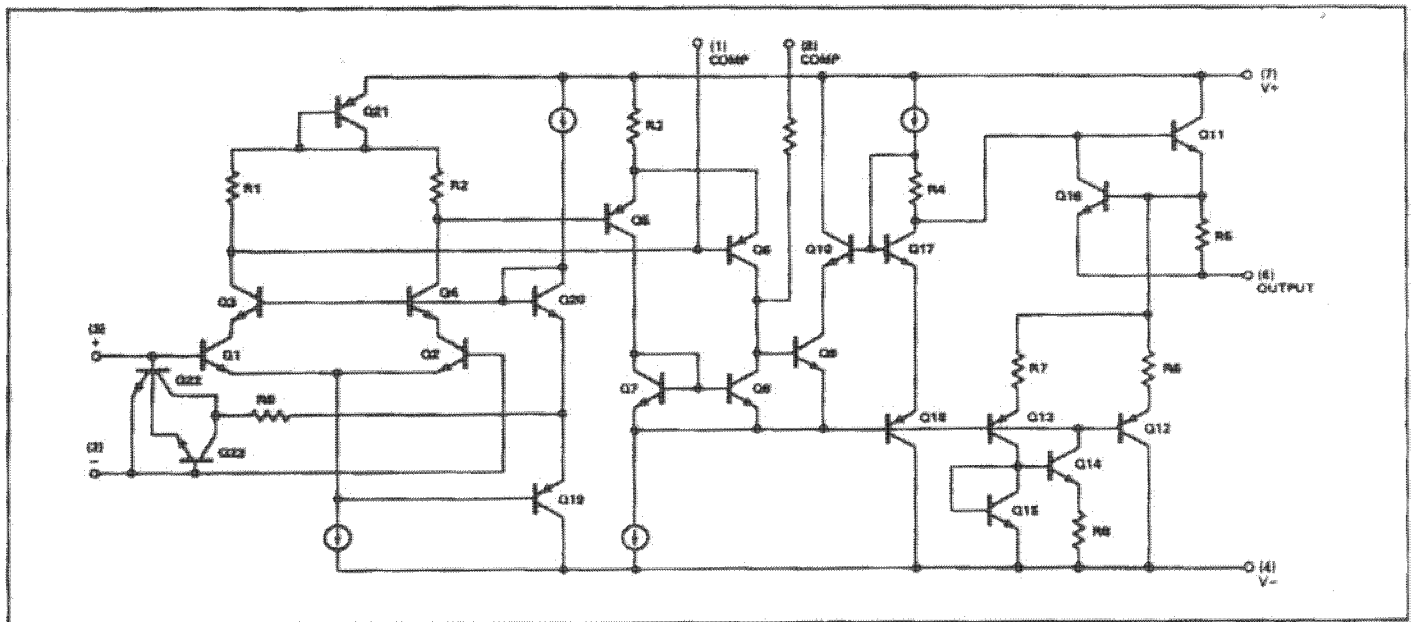

# PM-108/PM-208/PM-308

## ABSOLUTE MAXIMUM RATINGS (Note 3)

Supply Voltage	
PM-108A, PM-108, PM-208, PM-108ARC	±20V
PM-308A, PM-308	±18V
Differential Input Current (Note 2)	±10mA
Input Voltage (Note 3)	±15V
Output Short-Circuit Duration	Indefinite
Operating Temperature Range	
PM-108A, PM-108, PM-108ARC	-55°C to +125°C
PM-208	-25°C to +85°C
PM-308A, PM-308	0°C to +70°C
Storage Temperature Range	
(Q-, J-, Z- or ARC-Package)	-65°C to +150°C
(P-Package)	-65°C to +125°C
Lead Temperature (Soldering, 60 sec)	+300°C

PACKAGE TYPE	$\theta_{JA}$ (Note 1)	$\theta_{JC}$	UNITS
TO-99 (J)	150	18	°C/W
8-Pin Hermetic DIP (Z)	148	16	°C/W
8-Pin Plastic DIP (P)	103	43	°C/W
20-Contact LCC (RC)	98	38	°C/W

### NOTES:

- $\theta_{JA}$  is specified for worst case mounting conditions, i.e.,  $\theta_{JA}$  is specified for device in socket for TO, CerDIP, P-DIP, and LCC packages.
- The inputs are shunted with back-to-back diodes for overvoltage protection. Therefore, if a differential input voltage in excess of 1V is applied between the inputs, excessive current will flow, unless some limiting resistance is provided.
- For supply voltages less than ±15V, the absolute maximum input voltage is equal to the supply voltage.

## ELECTRICAL CHARACTERISTICS at ±5V ≤ V<sub>S</sub> ≤ ±20V and T<sub>A</sub> = 25°C, unless otherwise noted.

PARAMETER	SYMBOL	CONDITIONS	PM-108A			PM-108 PM-208			UNITS
			MIN	TYP	MAX	MIN	TYP	MAX	
Input Offset Voltage	V <sub>OS</sub>		—	0.3	0.5	—	0.7	2.0	mV
Input Offset Current	I <sub>OS</sub>		—	0.06	0.2	—	0.05	0.2	nA
Input Bias Current	I <sub>B</sub>		—	0.8	2.0	—	0.8	2.0	nA
Input Resistance	R <sub>IN</sub>	(Note 1)	30	70	—	30	70	—	MΩ
Large-Signal Voltage Gain	A <sub>VO</sub>	V <sub>S</sub> = ±15V, V <sub>OUT</sub> = ±10V, R <sub>L</sub> ≥ 10kΩ	80	300	—	50	300	—	V/mV
Supply Current	I <sub>SV</sub>	I <sub>OUT</sub> = 0, V <sub>OUT</sub> = 0, Each Amplifier	—	0.3	0.6	—	0.3	0.6	mA

## ELECTRICAL CHARACTERISTICS at ±5V ≤ V<sub>S</sub> ≤ ±20V, -55°C ≤ T<sub>A</sub> ≤ +125°C for PM-108A, PM-108, -25°C ≤ T<sub>A</sub> ≤ +85°C for PM-208, unless otherwise noted.

PARAMETER	SYMBOL	CONDITIONS	PM-108A			PM-108 PM-208			UNITS
			MIN	TYP	MAX	MIN	TYP	MAX	
Input Offset Voltage	V <sub>OS</sub>		—	0.4	1.0	—	1.0	3.0	mV
Average Input Offset Voltage Drift	TCV <sub>OS</sub>	(Note 2)	—	1	5	—	3	15	μV/°C
Input Offset Current	I <sub>OS</sub>		—	0.1	0.4	—	0.1	0.4	nA
Average Input Offset Current Drift	TCI <sub>OS</sub>	(Note 2)	—	0.5	2.5	—	0.5	2.5	pA/°C
Input Bias Current	I <sub>B</sub>		—	1	3	—	1	3	nA
Large-Signal Voltage Gain	A <sub>VO</sub>	V <sub>S</sub> = ±15V, V <sub>OUT</sub> = ±10V, R <sub>L</sub> ≥ 10kΩ	40	200	—	25	200	—	V/mV
Output Voltage Swing	V <sub>O</sub>	V <sub>S</sub> = ±15V, R <sub>L</sub> = 10kΩ	±13	±14	—	±13	±14	—	V
Input Voltage Range	IVR	V <sub>S</sub> = ±15V	±13.5	—	—	±13.5	—	—	V
Common-Mode Rejection Ratio	CMRR	V <sub>S</sub> = ±15V, V <sub>CM</sub> = ±13.5V	98	110	—	85	100	—	dB
Power-Supply Rejection Ratio	PSRR	V <sub>S</sub> = ±5V to ±20V	—	3	15	—	15	100	μV/V
Supply Current	I <sub>SV</sub>	V <sub>OUT</sub> = 0, T <sub>A</sub> = MAX, Each Amplifier	—	0.15	0.4	—	0.15	0.4	mA

### NOTES:

- Guaranteed by input bias current.
- Sample tested.

# PM-108/PM-208/PM-308

**ELECTRICAL CHARACTERISTICS** at  $\pm 5V \leq V_S \leq \pm 15V$  and  $T_A = 25^\circ C$ , unless otherwise noted.

PARAMETER	SYMBOL	CONDITIONS	PM-308A			PM-308			UNITS
			MIN	TYP	MAX	MIN	TYP	MAX	
Input Offset Voltage	$V_{OS}$		—	0.3	0.5	—	2.0	7.5	mV
Input Offset Current	$I_{OS}$		—	0.2	1.0	—	0.2	1.0	nA
Input Bias Current	$I_B$		—	1.5	7.0	—	1.5	7.0	nA
Input Resistance	$R_{IN}$	(Note 1)	10	40	—	10	40	—	MΩ
Large-Signal Voltage Gain	$A_{VO}$	$V_S = \pm 15V, V_{OUT} = \pm 10V,$ $R_L \geq 10k\Omega$	60	300	—	25	300	—	V/mV
Supply Current	$I_{EV}$	$I_{OUT} = 0, V_{OUT} = 0,$ Each Amplifier	—	0.3	0.8	—	0.3	0.8	mA

**ELECTRICAL CHARACTERISTICS** at  $\pm 5V \leq V_S \leq \pm 15V$  and  $0^\circ C \leq T_A \leq +70^\circ C$ , unless otherwise noted.

PARAMETER	SYMBOL	CONDITIONS	PM-308A			PM-308			UNITS
			MIN	TYP	MAX	MIN	TYP	MAX	
Input Offset Voltage	$V_{OS}$		—	0.4	0.73	—	3.0	10.0	mV
Average Input Offset Voltage Drift	$TCV_{OS}$	(Note 1)	—	1	5	—	6	30	$\mu V/^\circ C$
Input Offset Current	$I_{OS}$		—	0.3	1.5	—	0.3	1.5	nA
Average Input Offset Current Drift	$TCI_{OS}$	(Note 1)	—	2	10	—	2	10	$pA/^\circ C$
Input Bias Current	$I_B$		—	2	10	—	2	10	nA
Large-Signal Voltage Gain	$A_{VO}$	$V_S = \pm 15V, V_{OUT} = \pm 10V,$ $R_L \geq 10k\Omega$	60	200	—	15	100	—	V/mV
Output Voltage Swing	$V_O$	$V_S = \pm 15V, R_L = 10k\Omega$	$\pm 13$	$\pm 14$	—	$\pm 13$	$\pm 14$	—	V
Input Voltage Range	$I_{VR}$	$V_S = \pm 15V$	$\pm 14$	—	—	$\pm 13$	—	—	V
Common-Mode Rejection Ratio	CMRR	$V_{CM} = \pm 13.5V$	96	110	—	80	100	—	dB
Power-Supply Rejection Ratio	PSRR	$V_S = \pm 5V$ to $\pm 15V$	—	3	15	—	15	100	$\mu V/V$
Supply Current	$I_{EV}$	$V_{OUT} = 0, T_A = MAX,$ Each Amplifier	—	0.23	—	—	0.23	—	mA

**NOTE:**

1. Guaranteed by input bias current.

**PIN CONNECTIONS**

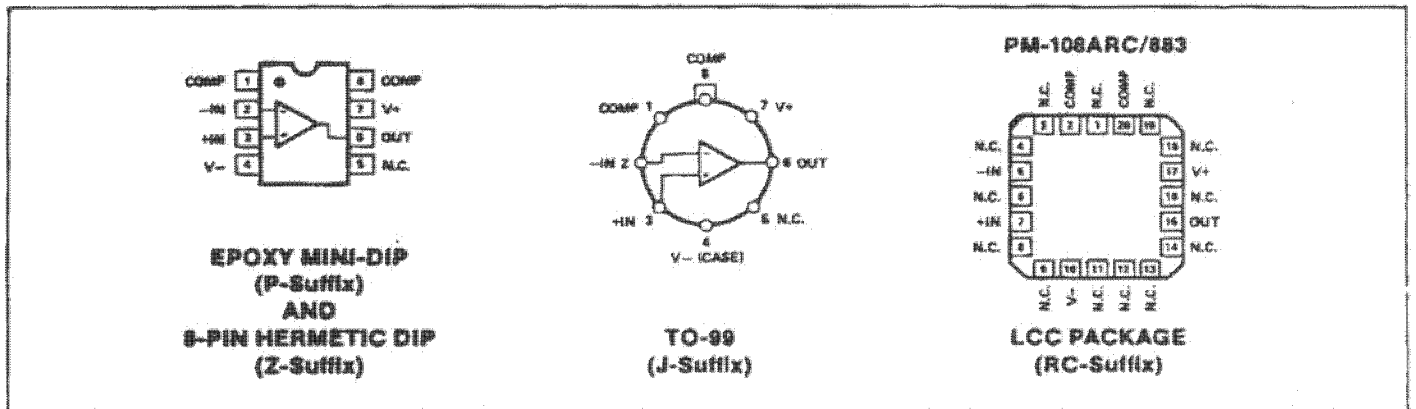

# PM-108/PM-208/PM-308

## BURN-IN CIRCUIT

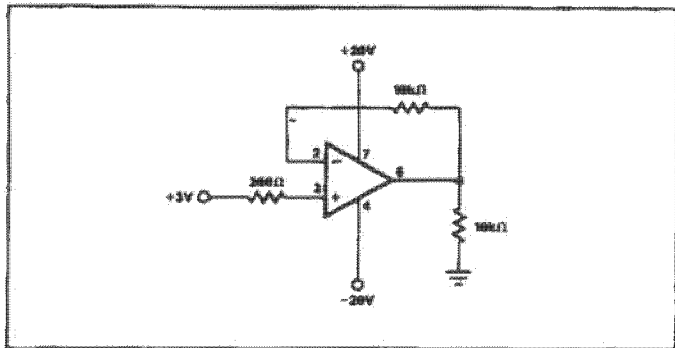

## COMPENSATION CIRCUITS

### STANDARD

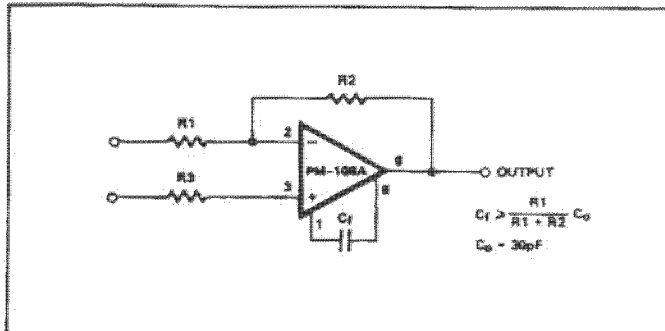

## APPLICATIONS INFORMATION

The PM-108A series has very low input offset and bias currents; the user is cautioned that printed circuit board leakages can produce significant errors, especially at high board temperatures. Careful attention to board layout and cleaning procedure is required to achieve the PM-108A's rated performance. It is suggested that board leakage be minimized by encircling the input pins with a guard ring maintained at a potential close to that of the inputs. The guard ring should be driven by a low impedance source such as an amplifier's output or ground.

### ALTERNATE

