

QMA

Adaptor
QMA Plug – N Jack

28S153-K00N5

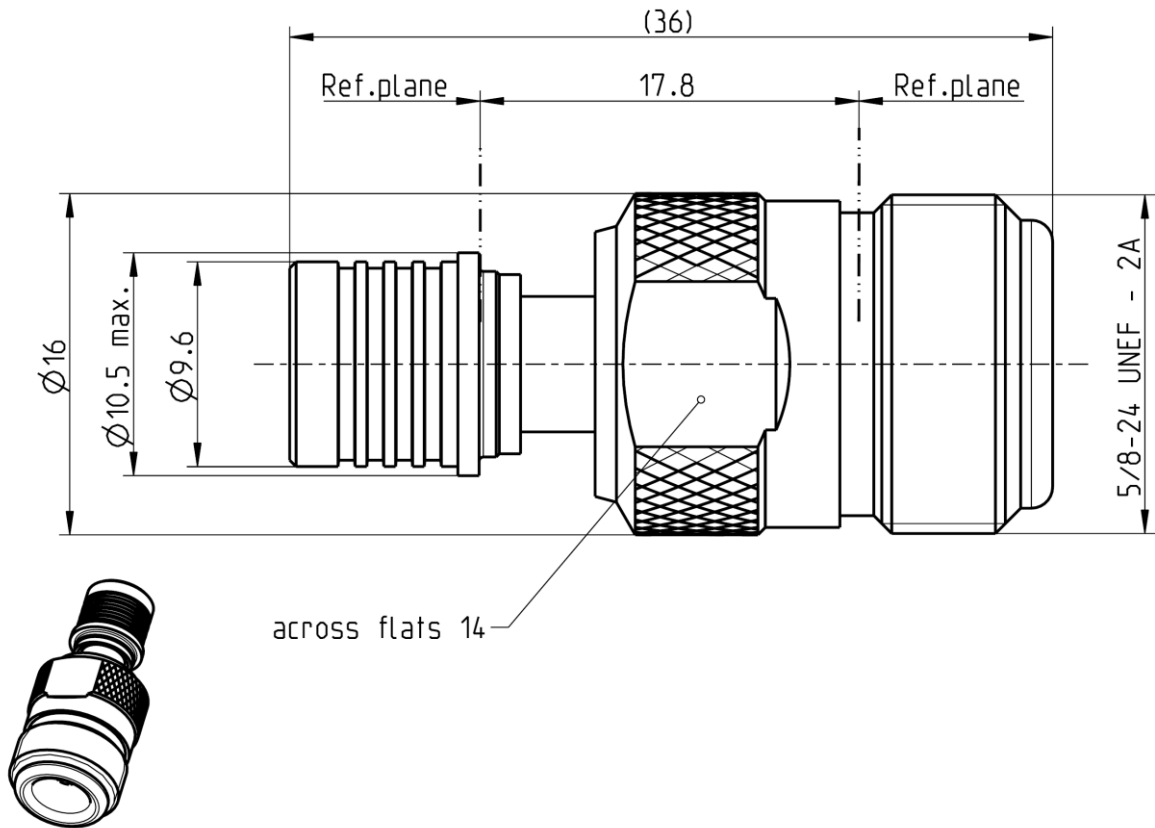

All dimensions are in mm; tolerances according to ISO 2768 m-H

Interface

According to	N side	IEC 61169-16, MIL-PRF-39012, CECC 22210
	QMA side	IEC 61169-50

Documents

N/A

Material and plating

Connector parts

Center contact
Outer contact QMA side
Outer contact N side
Body
Dielectric

Material

CuBe
Spring bronze
Brass
Brass
PTFE

Plating

AuroDur®, gold plated
White bronze(e.g. Optalloy®)
Flash white bronze over silver(e.g. Optargen®)
Flash white bronze over silver(e.g. Optargen®)

Dieses Dokument ist urheberrechtlich geschützt • This document is protected by copyright • Rosenberger Hochfrequenztechnik GmbH & Co. KG

RF_35/09.14/6.2

Electrical data

Impedance	50 Ω	
Frequency	DC to 11 GHz	
Return loss	≥ 32 dB, DC to 3 GHz	
	≥ 21 dB, 3 to 8 GHz	
Insertion loss	≤ 0.05 dB	
Insulation resistance	≥ 5 x10 ³ MΩ	
Center contact resistance	≤ 1 mΩ, N side	≤ 3 mΩ, QMA side
Outer contact resistance	≤ 0.25 mΩ, N side	≤ 2.5 mΩ, QMA side
Test voltage (at sea level)	1000 V rms	
Working voltage (at sea level)	480 V rms	
RF-leakage	≥ 95 dB up to 2 GHz	
Intermodulation (3 rd order)	≤ -130 dBc @ 2 x 20 W, 1800 MHz	

Mechanical data

	N side	QMA side
Mating cycles	min. 500	min. 100
Center contact captivation: axial	≥ 28 N	≥ 28 N
Coupling test torque	max. 1.7 Nm	N/A
Recommended torque	0.7 Nm to 1.1 Nm	N/A
Engagement force	N/A	typ. 25N
Disengagement force	N/A	typ. 20N
Retention force for interface	N/A	60N min.

Environmental data

Temperature range	-40°C to +85°C
Storage temperature	-40°C to +85°C
Thermal shock	IEC 60169-1 16.4 (-40 / +85°C)
Corrosion	IEC 60169-1 16.7 (48 hrs)
Vibration	IEC 60068-2-64 random
Damp heat, steady state	IEC 60169-1 16.3 (96 hrs)
RoHS	compliant

Weight

Weight	27 g/pce
--------	----------

While the information has been carefully compiled to the best of our knowledge, nothing is intended as representation or warranty on our part and no statement herein shall be construed as recommendation to infringe existing patents. In the effort to improve our products, we reserve the right to make changes judged to be necessary.

For the installation of the electrotechnical equipment, particular electrotechnical expertise is required.



Dieses Dokument ist urheberrechtlich geschützt • This document is protected by copyright • Rosenberger Hochfrequenztechnik GmbH & Co. KG

RF_35/09.14/6.2

Draft	Date	Approved	Date	Rev.	Engineering change number	Name	Date
Schmid Markus	20.03.06	Chr. Janßen	03.11.20	d00	20-1927	S. Huber-Siegl	03.11.20
Rosenberger Hochfrequenztechnik GmbH & Co. KG P.O.Box 1260 D-84526 Tittmoning Germany www.rosenberger.de						Tel. : +49 8684 18-0 Email : info@rosenberger.de	
						Page 2 / 2	