

12X PCB LTC KIT	CABLE GAUGE	24AWG	26AWG	28AWG
	DIM 'C'	6.30	6.30	5.20
	DIM 'D'	16.54	12.60	10.40
	PART NO.	91635-1010	91635-1011	91635-1012

4X PCB LTC KIT	CABLE GAUGE	24AWG	26AWG	28AWG
	DIM 'A'	3.95	3.95	3.45
	DIM 'B'	10.30	7.90	6.90
	PART NO.	91635-1020	91635-1021	91635-1022

ITEM	DESCRIPTION	QTY
▽1	HSG & TERMS SUB ASSY	1
▽2	PCB	1
▽3	LWR D/C SHELL	1
▽4	UPR D/C SHELL	1
▽5	LTC & OVERMOULD	2
▽6	SPRING	2
▽7	SCREW	2

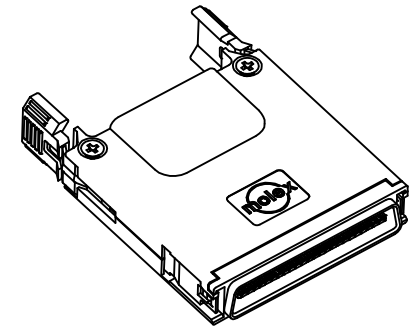
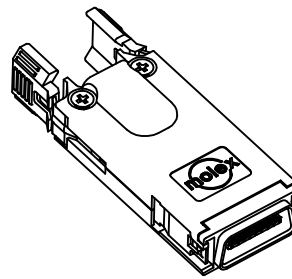
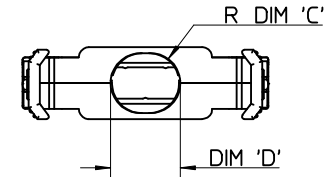
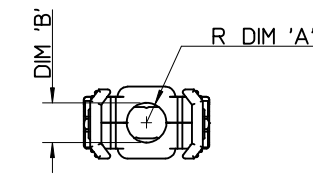
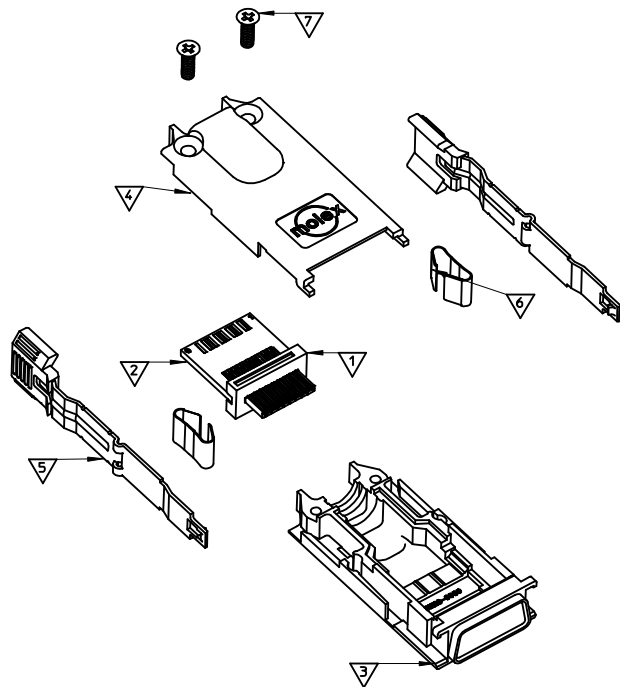

4X KIT

12X KIT

NOTES:

1. PRODUCT SPECIFICATION: PS-91525-001
2. SPECIFIED QTY OF COMPONENTS ARE PER KIT.
3. TWO KITS REQUIRED PER HARNESS.
4. THE HOUSING AND SIGNAL TERMINAL SUB-ASSEMBLY (ITEM 1) HAS BEEN DESIGNED TO FLOAT IN THE LOWER DIECAST SHELL (ITEM 3); THAT IS, THE HOUSING ASSEMBLY MAY MOVE EITHER HORIZONTALLY OR VERTICALLY IN THE DIECAST SHELL TO ALLOW THE PLUG HOUSING ALIGN ITSELF WITH THE RECEPTACLE DURING INSERTION. THE CABLE ASSEMBLY PROCESS SHOULD NOT IMPAIR THIS DESIGN FEATURE.

REMOVED EO PCB OPTION EC NO: E2004-0499 DRWN: MREYES 2004/01/13 CHKD: 2004/01/14 APPR: JWALLACE 2004/01/14	QUALITY SYMBOLS	GENERAL TOLERANCES (UNLESS SPECIFIED)		SCALE 2:1	DESIGN UNITS METRIC	THIRD ANGLE PROJECTION	REVISE ON CAD ONLY
	▽ -0	mm	INCH	DIMENSION STYLE MM ONLY		TITLE	
	▽/C -0	4 PLACES ± --- ± ---	3 PLACES ± --- ± ---	DRAWN BY MREYES	DATE 2002/11/29	LANELINK M CONN 4X AND 12X PCB LTC KIT	
		2 PLACES ± 0.1 ± ---	1 PLACE ± 0.2 ± ---	CHECKED BY JWALLACE	DATE 2002/11/29	MOLEX INCORPORATED	
	ANGULAR ± 2 °	DRAFT WHERE APPLICABLE MUST REMAIN WITHIN DIMENSIONS		APPROVED BY MWILHITE	DATE 2002/11/29	MATERIAL NO. SEE TABLE	DOCUMENT NO. SD-91635-001
				THIS DRAWING CONTAINS INFORMATION THAT IS PROPRIETARY TO MOLEX INCORPORATED AND SHOULD NOT BE USED WITHOUT WRITTEN PERMISSION		SHEET NO. 1 OF 1	A3