

QUICK START GUIDE FOR DEMONSTRATION CIRCUIT 1234

HIGH POWER, DUAL PHASE SYNCHROUSE BOOST CONVERTER

LT3782, LTC4440

DESCRIPTION

Demonstration circuit DC1234 is a DC/DC boost converter featuring the LT3782 constant frequency current mode boost controller. The synchronous rectification based on high side driver LTC4440 significantly improves converter efficiency. The DC1234 operates over 10V to 15V input voltage range and provides 8A of output current at 24V output. The 250 kHz constant frequency operation results in a small and efficient circuit. The converter provides high output voltage accuracy (typically $\pm 3\%$) over wide load range with no minimum load requirement. The demonstration circuit can be easily modified to generate

different output voltages. Please consult LTC factory for details. The DC1234 has a small circuit footprint. It is a high performance and cost effective solution for Telecom, Automotive and Industrial applications.

Design files for this circuit board are available. Call the LTC factory.

LTC is a trademark of Linear Technology Corporation

Table 1. Performance Summary ($T_A = 25^\circ\text{C}$)

PARAMETER	CONDITIONS	VALUE
Minimum Input Voltage		10.0V
Maximum Input Voltage		15.0V
Maximum Output Current		8.0A
Output Voltage		24.0V $\pm 3\%$
Typical Output Ripple	$V_{IN} = 12\text{V}$, $I_{OUT} = 6.0\text{A}$ (20 MHz BW)	$<120\text{mV}_{P-P}$
Efficiency	$V_{in} 10\text{V}$, $I_o 8.0\text{A}$	96%
	$V_{in} 12\text{V}$, $I_o 8.0\text{A}$	97%
	$V_{in} 15\text{V}$, $I_o 8.0\text{A}$	97%
Switching Frequency		250kHz

QUICK START PROCEDURE

Demonstration circuit DC1234 is easy to set up to evaluate the performance of the LT3782 in a synchronous rectification application. For proper measurement equipment setup refer to Figure 1 and follow the procedure below:

NOTE: When measuring the input or output voltage ripple, care must be taken to minimize the length of the oscilloscope probe ground lead. Measure the input or output voltage ripple by connecting the probe tip directly across the VIN or VOUT and GND terminals as shown in Figure 2

1. With power off, connect the input power supply to VIN and GND. Connect load to VOUT and GND terminals; make sure that load does not exceed 8.0A.
2. Check the VCC Bias voltage-setting jumper JP1. Move it to the VIN position.
3. Turn the input power source on and slowly increase the input voltage. Be careful not to exceed 15V.

NOTE: Make sure that the input voltage VIN does not exceed 15V. If higher operating voltage is required, power components with higher power ratings should be used. Also, Jumper VCC Bias JP1 will have to be moved to the LR position. Keep it in VIN position if input voltage less than 15V. Please consult LTC factory for details.

4. Check for the proper output voltage of 24V. If there is no output, temporarily disconnect the load to make sure that the load is not set too high.
5. Once the proper output voltage is established, adjust the load within the 8A range and observe

the output voltage regulation, ripple voltage, efficiency and other parameters

PROGRAMMING OF MAXIMUM DUTY CYCLE

Maximum Duty Cycle can be programmed by the voltage on DCL pin. In this case the DCL pin voltage can be derived from Rset pin. The Rset pin generates a 2.3V reference voltage that can be divided down to the desired value by resistors R28 and R32.

Keep in mind that combine value of R28+R32 are used to set the switching frequency also. In order to keep frequency constant, R28+R32 should stay constant as well. Please refer to the datasheet for more information.

Warning – This board is not designed to work with input voltages greater than a maximum of 15V. OVLO circuit based on transistor Q5 disables converter's operation, if input voltage exceeds maximum plus 25-30%.

QUICK START GUIDE FOR DEMONSTRATION CIRCUIT 1234

HIGH POWER, DUAL PHASE SYNCHRONOUS BOOST CONVERTER

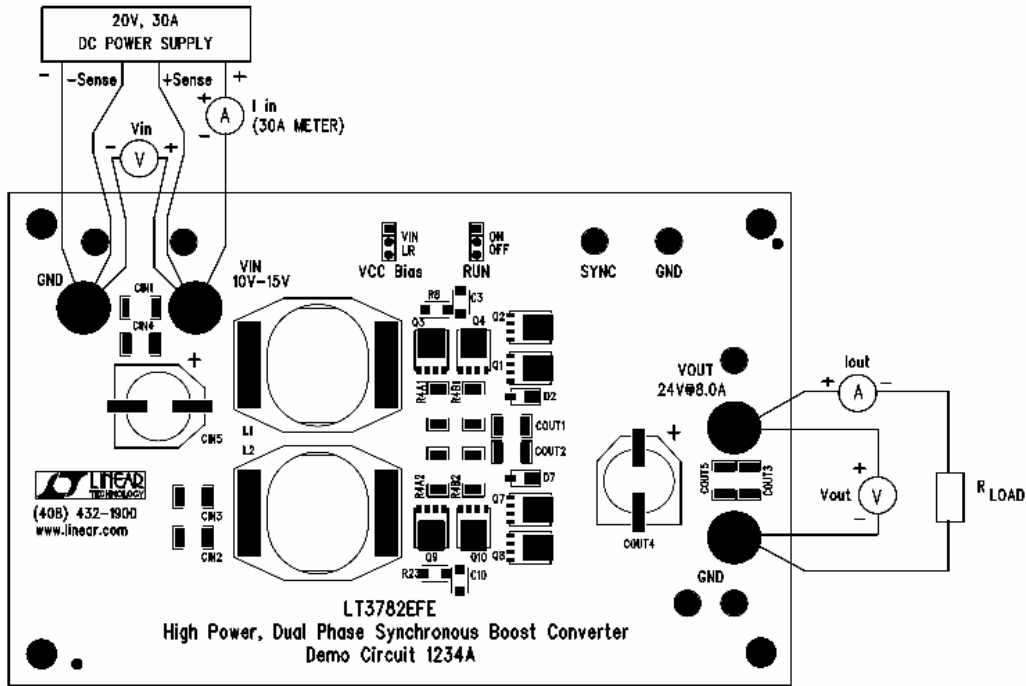

Figure 1. Proper Measurement Equipment Setup

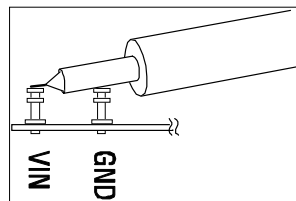
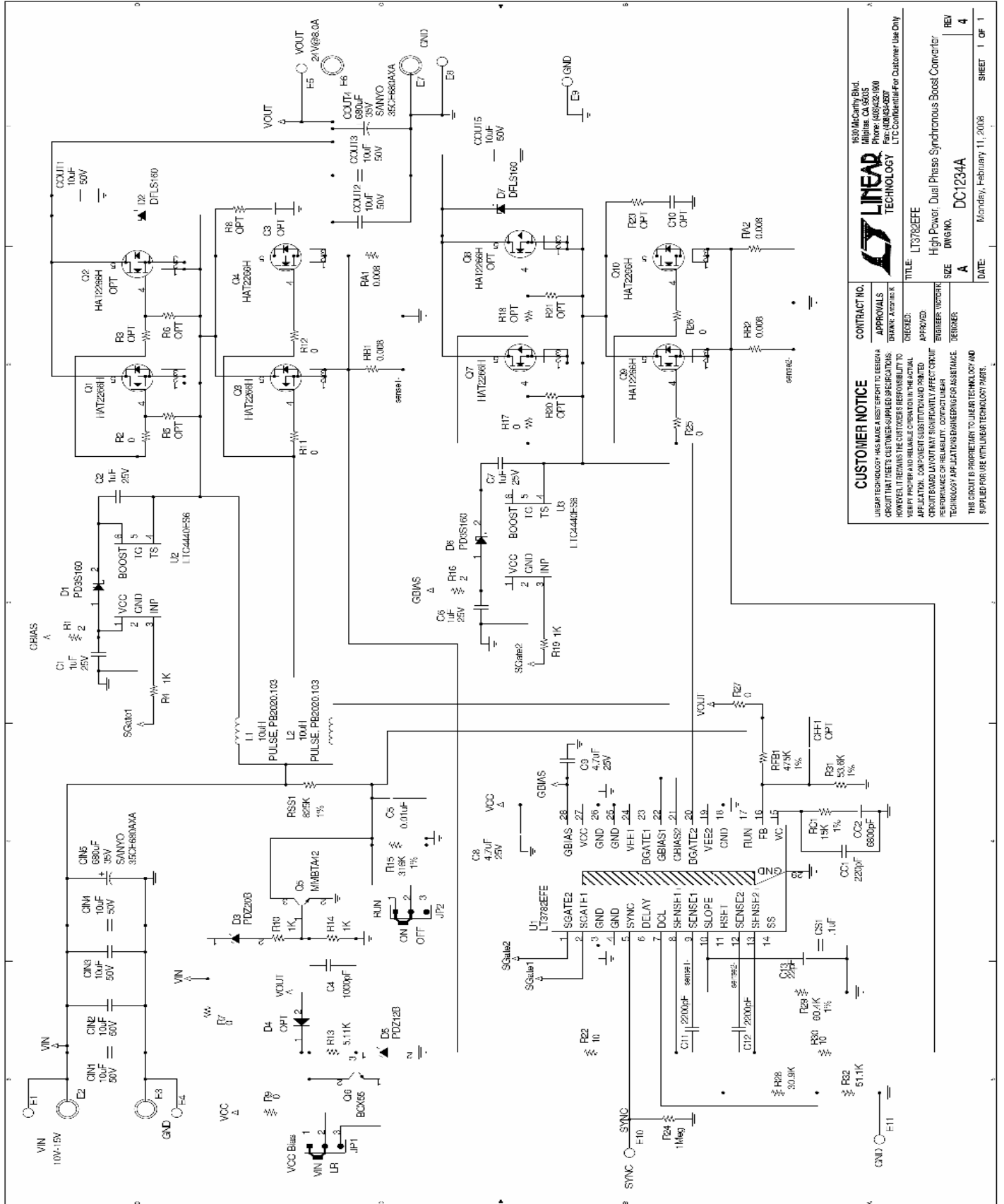

Figure 2. Measuring Input or Output Ripple

QUICK START GUIDE FOR DEMONSTRATION CIRCUIT 1234

HIGH POWER, DUAL PHASE SYNCHROUSE BOOST CONVERTER



CUSTOMER NOTICE		CONTRACT NO.	
LINEAR TECHNOLOGY HAS MADE A BEST EFFORT TO DESIGN A CIRCUIT THAT MEETS CUSTOMER-SUPPLIED SPECIFICATIONS. HOWEVER, IT REMAINS THE CUSTOMER'S RESPONSIBILITY TO VERIFY PROPER AND RELIABLE OPERATION IN THE ACTUAL APPLICATION. COMPONENT SUBSTITUTIONS AND PRINTED CIRCUIT BOARD LAYOUT MAY SIGNIFICANTLY AFFECT CIRCUIT PERFORMANCE OR RELIABILITY. CONTACT YOUR TECHNOLOGY APPLICATION ENGINEER FOR ASSISTANCE.		1630 McCarthy Blvd. Milpitas, CA 95035 Phone: (408)321-1500 Fax: (408)321-2000 LTC Customer Care For Customer Use Only	
APPROVALS		LINEAR TECHNOLOGY	
DESIGNED BY: [Blank]	CHECKED BY: [Blank]	LT3782EFE High Power, Dual Phase Synchronous Boost Converter DC1234A	
APPROVED BY: [Blank]	APPROVED BY: [Blank]		
DESIGNED BY: [Blank]	DESIGNED BY: [Blank]		
DESIGNED BY: [Blank]	DESIGNED BY: [Blank]		
REV	DATE	SIZE	REV
4	Monday, February 11, 2008	A	4
		DATE	SHEET 1 OF 1