

## SPEAKER-1115-4-SC-COBRA SF

The 11×15×4 mm COBRA SF is high-end miniature speaker of rectangular shape with lateral sound outlets. Specifically designed for side-firing applications, this speaker version enables a reduced application height in small, slim consumer devices, such as music phones, smartphones or tablet computers where high quality sound and maximum space efficiency are required.

In addition, COBRA SF features Knowles' advanced membrane technologies resulting in a state-of-the-art silicone membrane. This unique silicone membrane enables ultra-high excursion rates and superior robustness.



### Features:

- Lateral sound outlet integrated in cover of speaker
- Significant height reduction for side-firing applications
- 100% in-line measurement of all specified acoustical and electrical parameters
- Pre-tested and integrated side-porting acoustics
- Manufactured to the highest standards
- High power handling capacity of 1000mW

**Contents**

- 1. Theory of operation.....3
- 2. Mechanical Layout and Dimensions.....4
  - 2.1. Main dimensions .....4
  - 2.2. PWB layout & electric polarity .....5
  - 2.3. Magnetic polarity .....5
  - 2.4. Spring force .....6
  - 2.5. Part marking/labeling.....7
  - 2.6. Material list.....8
  - 2.7. Force on component .....9
- 3. Electrical and Acoustical Specifications.....10
  - 3.1. Frequency response .....10
  - 3.2. Electro-acoustic parameters .....11
  - 3.3. Power handling.....11
  - 3.4. Measured parameters.....12
  - 3.5. Measurement setup .....12
  - 3.6. Measurement adapter .....13
- 4. Environmental Conditions.....14
  - 4.1. Storage.....14
  - 4.2. Transportation.....14
  - 4.3. Functionality.....14
- 5. Environmental Tests.....15
  - 5.1. Qualification tests.....15
  - 5.2. Reliability tests .....15
  - 5.3. Sample size, sequence.....15
  - 5.4. Period of shelf-life .....15
  - 5.5. Testing procedures.....15
- 6. Related Documents .....19
- 7. Change History .....20
- 8. Disclaimer .....20



2403 260 00098

## 1. Theory of operation

SPEAKER-1115-4-SC-COBRA SF is an electrodynamic transducer, designed to translate electrical analog signals into acoustic waves. The input signal is fed into a coil which is exposed to a permanent magnetic field and where a membrane is attached to. Through the principle of the resulting electromagnetic force, the membrane is moved according to the contents of the input signal and thus emitting sound by the air shifted.

# 2403 260 00098

## 2. Mechanical Layout and Dimensions

### 2.1. Main dimensions

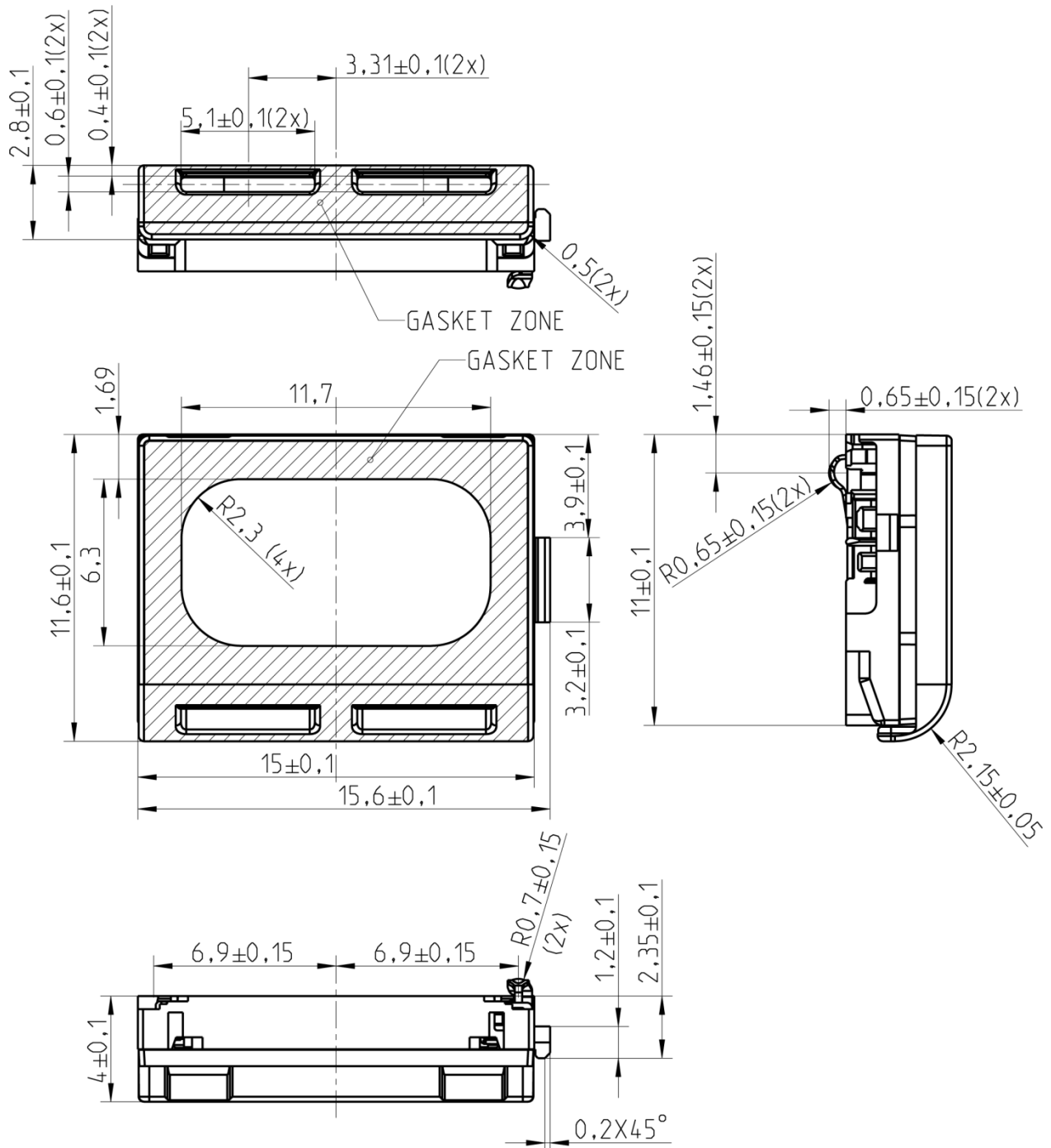

# 2403 260 00098

## 2.2. PWB layout & electric polarity

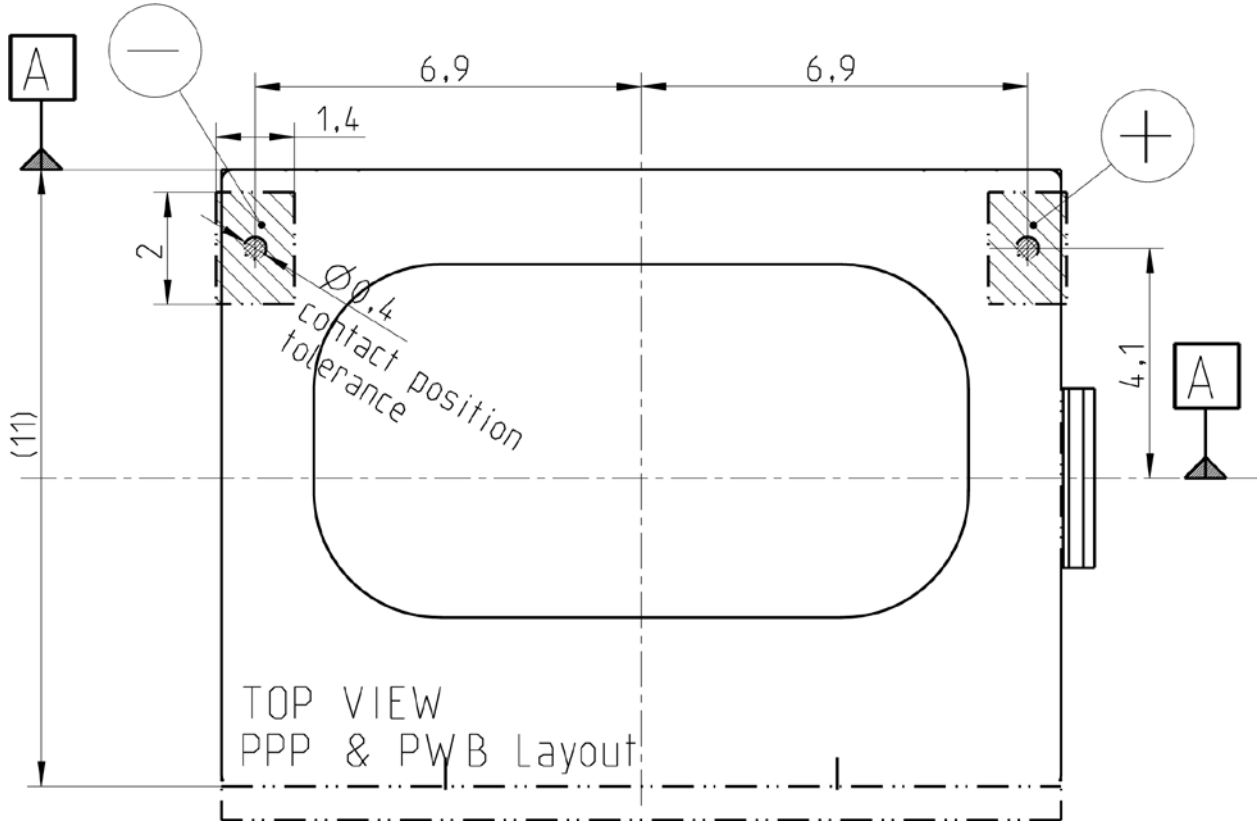

## 2.3. Magnetic polarity

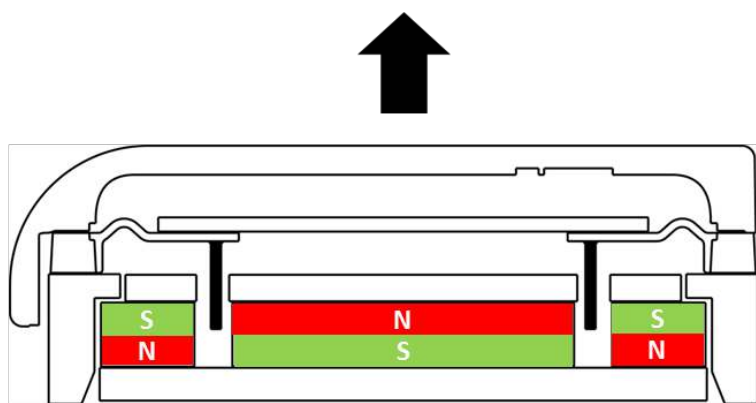
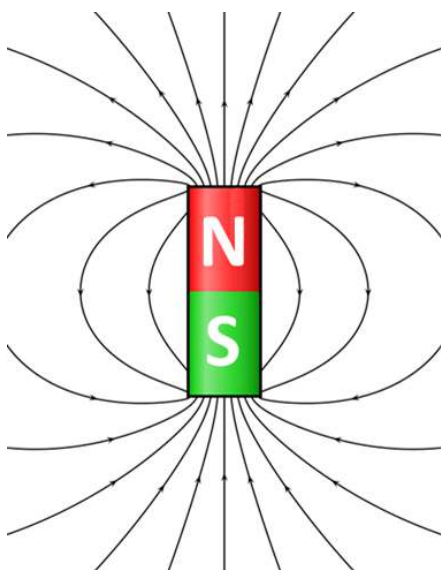

Positive voltage on pin +  
Moves the membrane in direction of arrow

# 2403 260 00098

## 2.4. Spring force

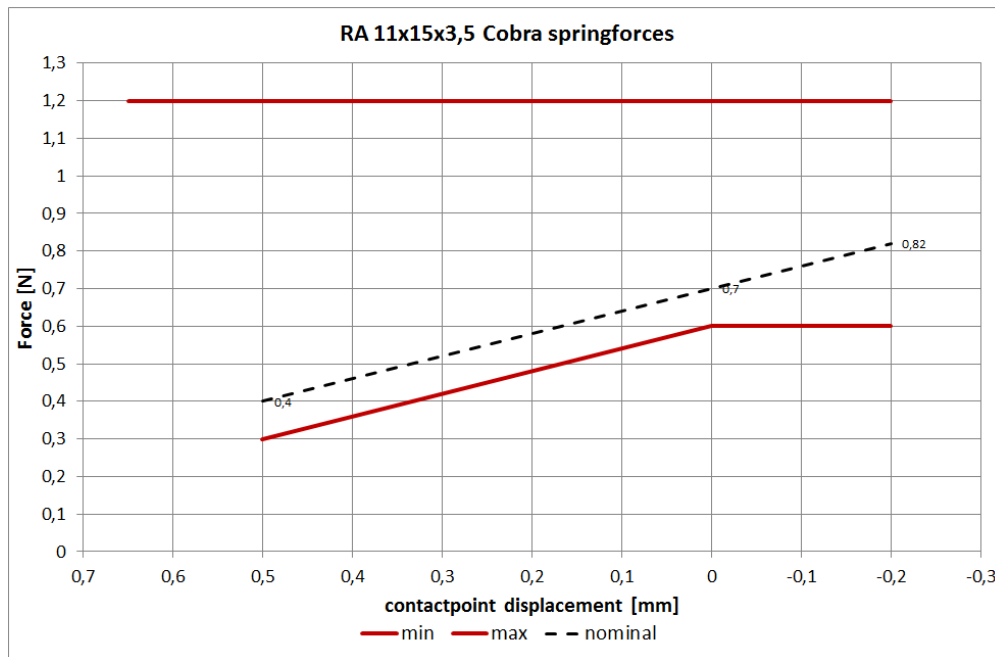
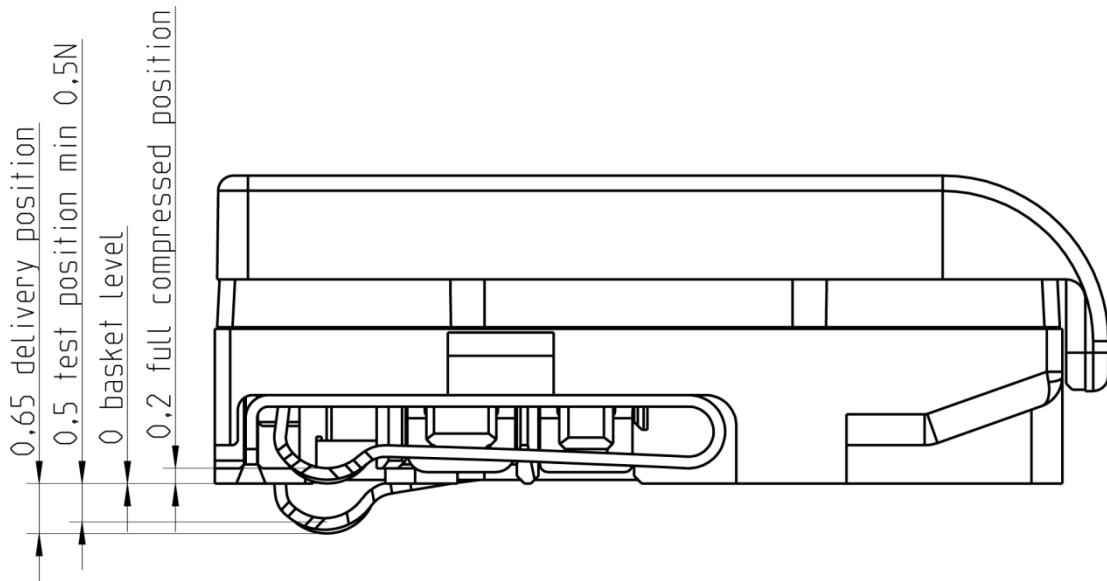

SPRING FORCE TABLE		
Force at Basket level	0.0 mm	min. 0.6 N
Force at Start Working position	0.5 mm	min. 0.3 N
uncompressed (delivery position)	0.65 ±0.15mm	0.0 N
Force at PPP level	-0.2 mm	max 1.2 N

2403 260 00098

## 2.5. Part marking/labeling

The samples have a serial number on bottom (pot) side

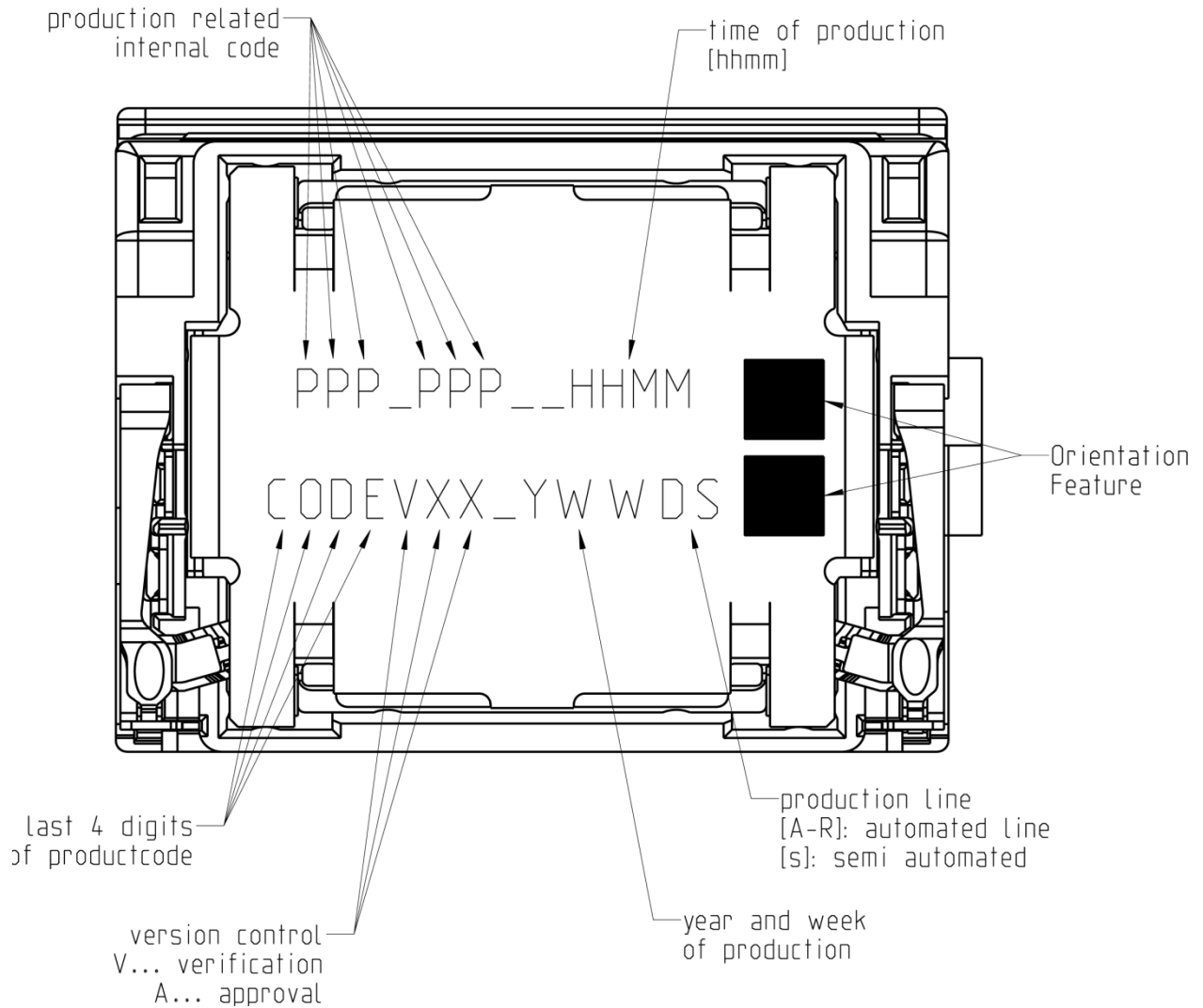

2403 260 00098

## 2.6. Material list

Material of basket:	Polycarbonate
Material of membrane:	Silicone
Material of membrane frame	Polybutylene Terephthalate (PBT)
Material of pot:	soft magnetic Iron
Material of magnet:	Nd Fe B
Material of contact	CrNi-Steel, gold plated
Material of cover:	Polycarbonate
Dimensions (in mm):	11 × 15 × 4
Mass:	1.56 g



# 2403 260 00098

## 2.7. Force on component

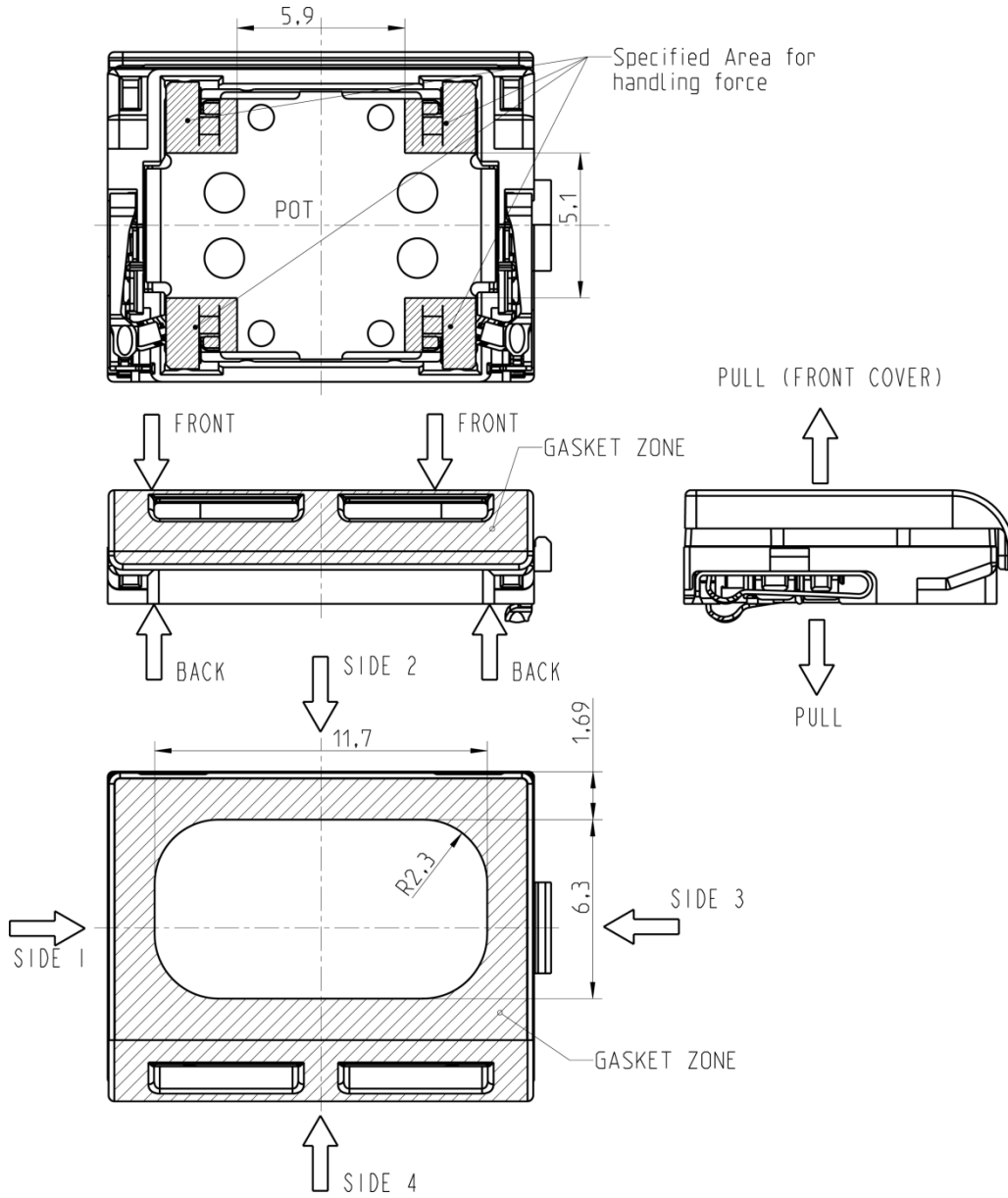

FORCES ON DIFFERENT STATE OF COMPONENT			
STATE	MIN. SURFACE OF PRESSURE [mm <sup>2</sup> ]	MAX. PERMANENT FORCE [N]	MAX. HANDLING FORCE [N]
FROM FRONT TO BACK (GASKET AREA)	-	10	15
FROM SIDE 1 TO SIDE 3	3	10	15
FROM SIDE 2 TO SIDE 4	10	10	15
TO POT	-	10	15
TO MEMBRANE	-	0	0
PULL OFF FORCE	-	0	20

# 2403 260 00098

## 3. Electrical and Acoustical Specifications

### 3.1. Frequency response

Typical frequency response measured on baffle according to chapter 3.5  
(distance  $d = 1\text{cm}$ ,  $p = 1000\text{mW}$ ,  $1\text{cm}^3$ )

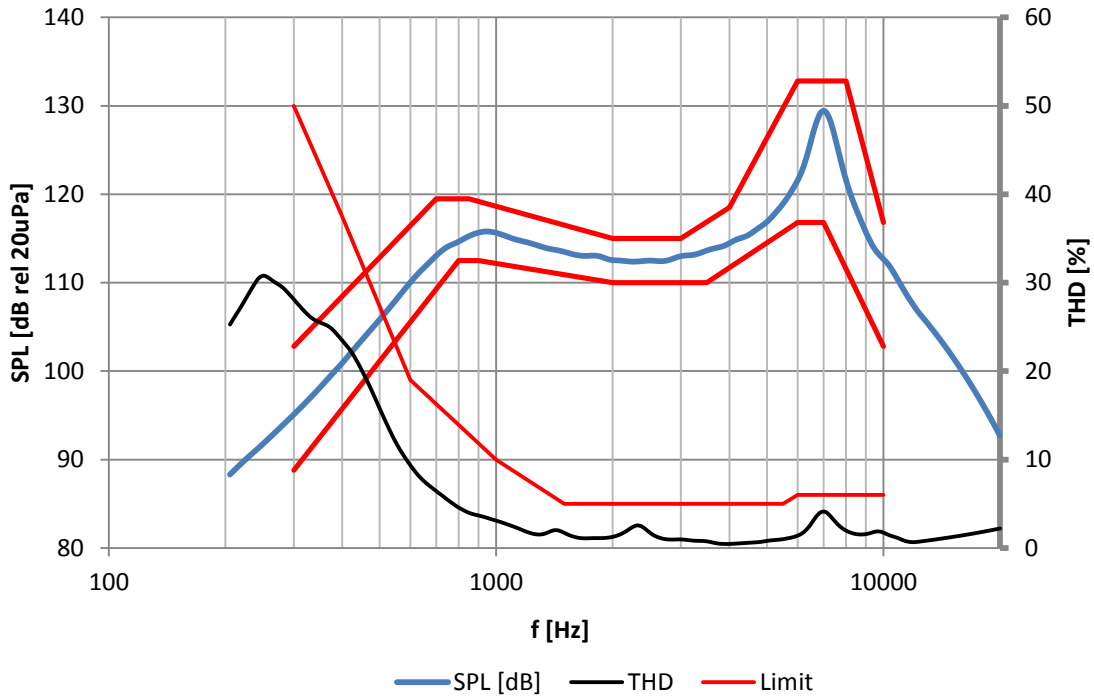

Tolerance window				
Frequency Response			THD	
f [Hz]	lower limit (floating) [dB]	upper limit (floating) [dB]	f [Hz]	upper limit [%]
300	88.8	102.8	300	50
700	-	119.5	450	37.5
800	112.5	-	650	19
850	-	119.5	1000	10
900	112.5	-	1300	5
2000	110	115	5500	5
3000	-	115	6000	6
3500	110	-	10000	6
4000	-	118.5		
6000	116.8	132.8		
7000	116.8	-		
8000	-	132.8		
10000	102.8	116.8		

# 2403 260 00098

## 3.2. Electro-acoustic parameters

Loudspeaker mounted in adapter acc. to 3.5.

1. Rated impedance	Z:	6Ω
2. Voice coil DC resistance	R:	5.4Ω±10%
3. Resonance frequency (measured @1cm <sup>3</sup> , 1000mW)	f <sub>0</sub> :	780Hz±10%
4. Maximum usable excursion (peak-to-peak)	x <sub>max</sub> :	0.74mm <sub>p-p</sub>
5. Nominal characteristic sensitivity (measured at 1W in 1cm, calculated to 1m average from 2kHz to 3kHz, thermal compression included)		73.5±2.5dB
5.1 Measured characteristic sensitivity (at 1W in 10cm) average from 2kHz to 3kHz		86.5±2dB
6. THD		according chapter 3.1
7. Rub & buzz		no audible Rub & Buzz

All acoustic measurements at 23±2°C

## 3.3. Power handling

Speaker mounted in 1cm<sup>3</sup> test device (open front)

1. Max sine Power		1000mW (RMS)
2. Max short term power (pink noise, 2 <sup>nd</sup> order high pass filtered, -3dB at 1.2kHz, crest factor 2)	(70°C, 1 sec. ON / 60sec. OFF)	1200mW (RMS)
3. Max continuous power (pink noise, 2 <sup>nd</sup> order high pass filtered, -3dB at 800Hz, crest factor 2)	(70°C, 500h)	1000mW (RMS)

### 3.4. Measured parameters

#### 3.4.1. Sensitivity

SPL is expressed in dB rel 20 $\mu$ Pa, computed according to IEC 268-5. Measurement set up and parameters according chapter 3.5. This test is performed for 100% of products in the production line.

#### 3.4.2. Frequency response

Frequency response is measured according test set up in chapter 3.3 data sheet and checked against the tolerance window defined in chapter 3.5. This Test is performed for 100% of products in the production line.

#### 3.4.3. Total harmonic distortion (THD)

Is measured according IEEE and test set up in chapter 3.5. This test is performed for 100% of products in the production line.

#### 3.4.4. Rub & buzz

Rub & buzz will be measured in the Inline-measuring device with a sinusoidal sweep. Rub and buzz is defined as the maximum peak sound pressure in transmission range of the 5kHz high pass filter. This test is performed for 100% of products in the production line.

### 3.5. Measurement setup

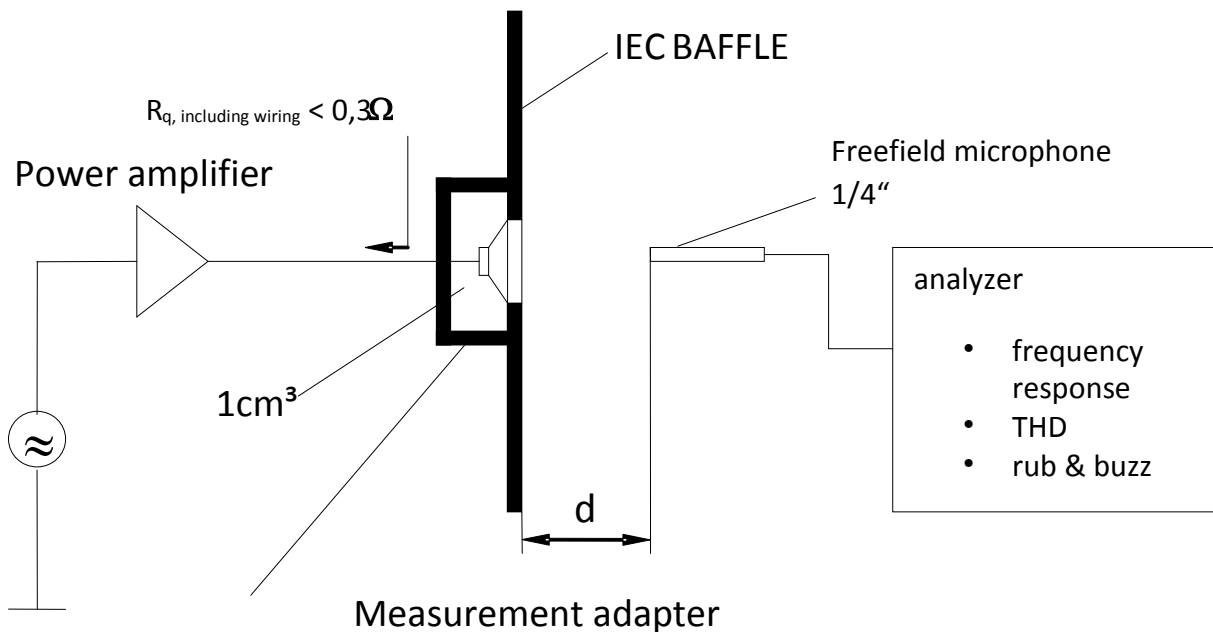

Measurement signal: Logarithmic sine sweep, 1.5s, 22kHz-180Hz

# 2403 260 00098

## 3.6. Measurement adapter

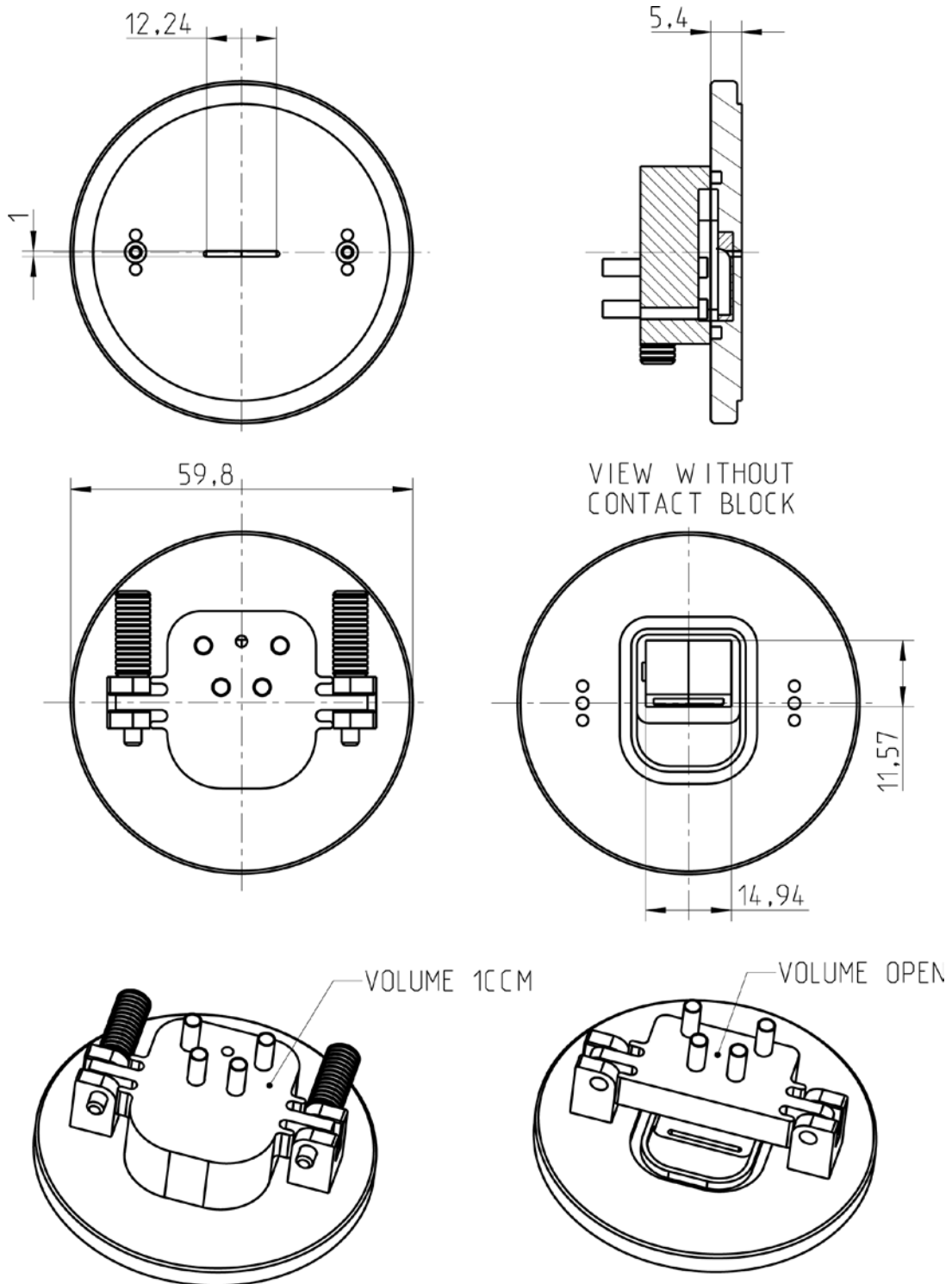

2403 260 00098

## 4. Environmental Conditions

### 4.1. Storage

The transducer fulfills the specified data after treatment according to the conditions of

**ETS 300 019-2-1**                      Specification of environmental test: Storage  
Test spec. T 1.2: Weather protected, not temperature controlled storage locations.

### 4.2. Transportation

The transducer fulfills the specified data after treatment according to the conditions of

**ETS 300 019-2-2**                      Specification of environmental test: Transportation  
Test Spec. T 2.3: Public Transportation

### 4.3. Functionality

The transducer fulfills the specified data after treatment according to the conditions of

**ETS 300 019-2-5**                      Specification of environmental test: Ground vehicle installations  
Test spec. T 5.1: Protected installation

**ETS 300 019-2-7**                      Specification of environmental test: Portable and non-stationary use  
Test spec. T 7.3E: Partly weather protected and non-weather protected locations.

## 5. Environmental Tests

### 5.1. Qualification tests

According to our milestone plan (Product Creation Process), a complete qualification test will be done at design validation of products manufactured under serial conditions.

1x per year and product family a requalification takes place. The qualification process covers all tests described under 4.5 and a complete inspection.

### 5.2. Reliability tests

1x per month and product family samples are taken and submitted to tests described under 4.5.2

### 5.3. Sample size, sequence

Unless otherwise stated 20 arbitrary new samples will be used to perform each test for both, qualification and requalification test as described under 4.1 and 4.2.

### 5.4. Period of shelf-life

The period of shelf-life is 2 years.

### 5.5. Testing procedures

#### 5.5.1. Storage tests

##### 5.5.1.1. Cold storage test

Parameter	Test Method and Conditions	Duration	Evaluation Standard
Low Temperature Storage (Ref. EN 60068-2-1)	-40°C rel. humidity not controlled	168h	Measurements after 2 hours recovery time. All samples fully operable. All acoustical parameters according specification with tolerances increased by 50 %.

##### 5.5.1.2. Heat storage test

Parameter	Test Method and Conditions	Duration	Evaluation Standard
Dry Heat Storage (Ref. EN 60068-2-2)	+85°C rel. humidity not controlled	168h	Measurements after 2 hours recovery time. All samples fully operable. All acoustical parameters according specification with tolerances increased by 50 %.

# 2403 260 00098

### 5.5.1.3. Temperature cycle test

Parameter	Test Method and Conditions	Duration	Evaluation Standard
Change of Temperature (Ref. EN 60068-2-14)	-40°C/+85°C Transition time <3 min. See Figure 4-1 below	5 cycles >2h for each temperature	Measurements after 2 hours recovery time. All samples fully operable. All acoustical parameters according specification with tolerances increased by 50 %.

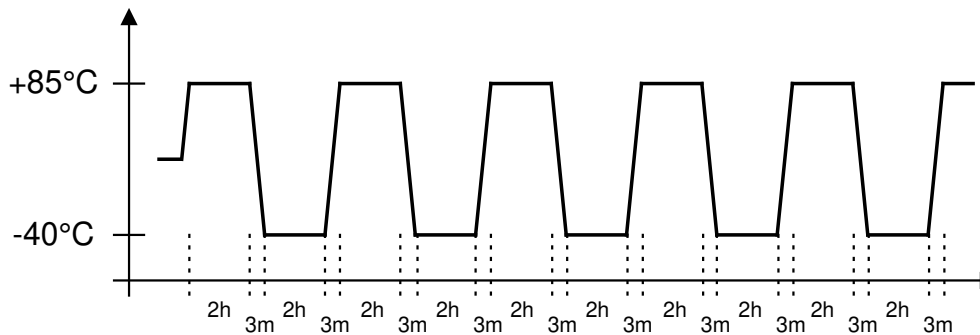

Figure 4-1: Temperature Cycle Test

### 5.5.1.4. Temperature/humidity cycle test

Parameter	Test Method and Conditions	Duration	Evaluation Standard
Damp heat, cyclic (Ref. IEC 60068-2-30)	+25°C/+55°C 90% to 95% RH. Temp. change time <3h See Figure 4-2 below <u>Caution:</u> no condensed water on products!	6 cycles. 12h at each temperature	Measurements after 2 hours recovery time. All samples fully operable. All acoustical parameters according specification with tolerances increased by 50 %.

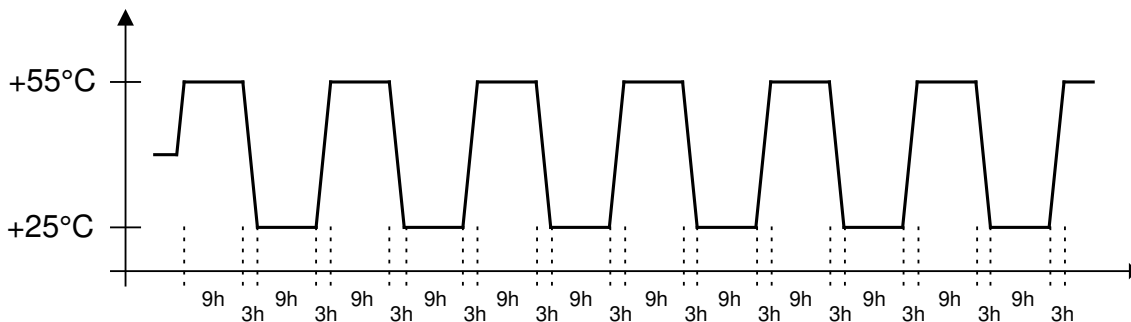

Figure 4-2: Temperature / Relative Humidity Cycle Test



2403 260 00098

**5.5.2. Operating tests**

**5.5.2.1. Cold operation test**

Parameter	Test Method and Conditions	Duration	Evaluation Standard
Cold Operation Test (Ref. EN 60068-2-1)	-20°C rel. humidity not controlled signal acc. chapter 3.3	72h	Measurements after 2 hours recovery time. All samples fully operable. THD may be increased after test. All other acoustical parameters according specification with tolerances increased by 50 %.

**5.5.2.2. Heat operation test**

Parameter	Test Method and Conditions	Duration	Evaluation Standard
Dry Heat Operation (Ref. EN 60068-2-2)	+70°C rel. humidity not controlled signal acc. chapter 3.3	500h	Measurements after 2 hours recovery time. All samples fully operable. The allowable change in sensitivity shall not be greater than 3 dB. All other acoustical parameters according specification with tolerances increased by 50 %.

**5.5.3. Salt mist test**

Parameter	Test Method and Conditions	Duration	Evaluation Standard
Salt Mist (Ref. IEC60068-2-52, Kb / Severity 2)	The part must be subjected to 2 hours spray of 5% NaCl salt mist, at 35°C then be left at 40°C and 95% RH for 22h.	3 cycles	The samples shall be washed after the test with distilled water and dried at T < 50°C. Component may have reduced performance, but must still function properly. The allowable sensitivity difference shall not be greater than ±3dB from initial sensitivity.



2403 260 00098

**5.5.4. Guided free fall test - protected product**

Parameter	Test Method and Conditions	Conditions / Sample size	Evaluation Standard
Mechanical shock (Ref. IEC60068-2-32 Ed), Procedure 1	Speaker in drop test box or representative mechanics from a height of 1.5m onto concrete floor.	30 units Two drops on each side (2x6) One drop on each edge (1x12) Two drops on each corner (2x8) (40 drops in total)	Component may have reduced performance, but must still function properly. The allowable sensitivity difference shall not be greater than $\pm 3$ dB from initial sensitivity.

**5.5.5. Random free fall test (tumble test) – protected product**

Parameter	Test Method and Conditions	Conditions / Sample size	Evaluation Standard
Impact durability (in a Tumble Tester) (Ref. IEC60068-2-32 Ed) (SPR a7.1.1)	Speaker <i>in drop test box</i> or representative mechanics. Random drops on steel base.	30 units 180 drops, 1m DUT power off	Component may have reduced performance, but must still function properly. The allowable sensitivity difference shall not be greater than $\pm 3$ dB from initial sensitivity.

**5.5.6. Resistance to electrostatic discharge**

Parameter	Test Method and Conditions	Conditions / Sample size	Evaluation Standard
Resistance to ESD IEC61000-4-2 Level 4 (SPR c 2.5.1)	One pole is grounded and the ESD pulse is applied to the other pole. The speaker must be stressed first with one polarisation and then with the other polarisation. DUT must be discharged between each ESD exposure. Level 4: contact +/- 8kV, air +/- 15kV	10 exposures on each polarity / 5 units DUT Power off	All samples fully operable. All acoustical parameters according specification with tolerances increased by 50%.

2403 260 00098

## 6. Related Documents

<b>IEC 268-5</b>	Sound System equipment Part 5: Loudspeaker
<b>IEC 68-2</b>	Environmental testing
<b>EN 60068-2</b>	Environmental testing
<b>ISO 2859 - 1</b>	Sampling procedures for inspection by attributes Part 1: Sampling plans indexed by acceptable quality level (AQL) for lot-by-lot inspection
<b>ISO 3951</b>	Sampling procedures and charts for inspection by variables for percent defectives.
<b>ETS 300 019-2-1</b>	Specification of environmental test: Storage Test spec. T 1.2: Weather protected, not temperature controlled storage locations
<b>ETS 300 019-2-2</b>	Specification of environmental test: Transportation Test spec. T 2.3: Public Transportation
<b>ETS 300 019-2-5</b>	Specification of environmental test: Ground vehicle installations Test spec. T 5.1: Protected installation
<b>ETS 300 019-2-7</b>	Specification of environmental test: Portable and non-stationary use Test spec. T 7.3E: Partly weather protected and non-weather protected locations

2403 260 00098

## 7. Change History

Status	Version	Date	ECR	Comment / Changes	Initials of owner
Release	A	05.08.13	4015	First release	BW/CP/ZG/EP/SG

## 8. Disclaimer

Stresses above the Absolute Maximum Ratings may cause permanent damage to the device. These are stress ratings only. The device may not function when operated at these or any other conditions beyond those indicated under “Electrical and Acoustical Specifications”. Exposure beyond those indicated under “Electrical and Acoustical Specifications” for extended periods may affect device reliability.

This product is not qualified for use in automotive applications

Frequency range in telecom application:  
300 Hz – 3.4 kHz

The information contained in this literature is based on our experience to date and is believed to be reliable and it is subject to change without notice. It is intended as a guide for use by persons having technical skill at their own discretion and risk. We do not guarantee favorable results or assume any liability in connection with its use. Dimensions contained herein are for reference purposes only. For specific dimensional requirements consult factory. This publication is not to be taken as a license to operate under, or recommendation to infringe any existing patents. This supersedes and voids all previous literature.