

REVISIONS				
P	LTN	DESCRIPTION	DATE	APVD
E		REDRAWN/REVISED PER ECO-17-001755	20NOV2017	KS JO

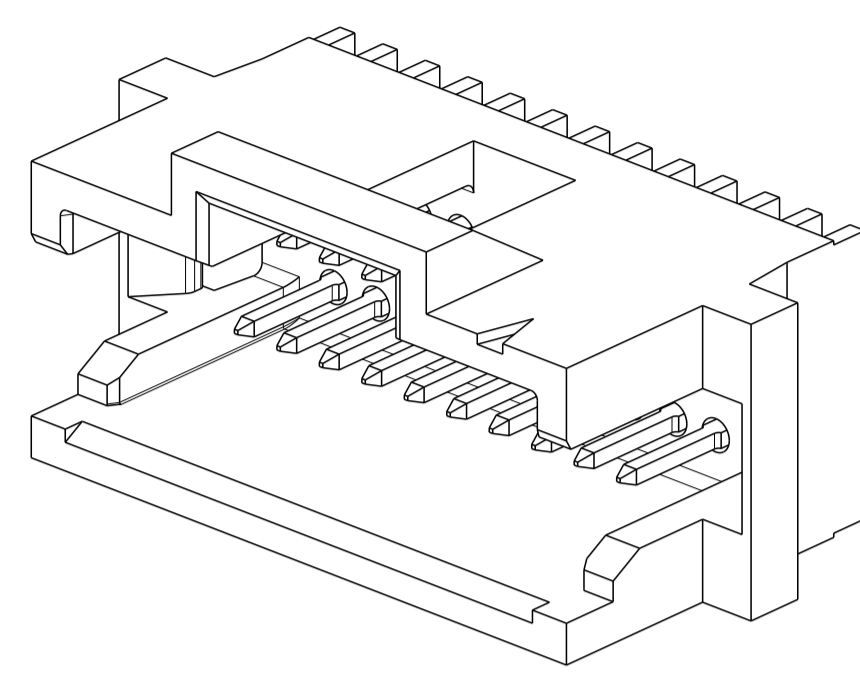

- 1 CONTACT AREAS PLATED WITH 0.76µM MIN GOLD; SOLDER TAILS PLATED WITH 3.81µM MIN TIN-LEAD, ALL OVER 1.27µM MIN NICKEL
- 2. NOTE DELETED.
- 3 CIRCUIT IDENTIFICATION FEATURE OMITTED ON 8, 10, 12, & 14 POSN HEADER ASSEMBLIES
- 4 DIMENSION APPLIES AT BASE OF SHROUD
- 5 THE NOTED DIMENSIONS APPLY AT THE INTERSECTION OF THE POST AND HOUSING
- 6. NOTE DELETED.
- 7 SAME AS 146397-1 EXCEPT PACKAGED ON G-PAX REELS.
- 8 SAME AS 5-146397-1 EXCEPT PACKAGED ON G-PAX REELS.
- 9 CONTACT AREAS PLATED WITH 0.76µM MIN GOLD; SOLDER TAILS PLATED WITH 3.81µM MIN TIN, ALL OVER 1.27µM MIN NICKEL.
- 10 FINISH: 0.03µM MIN GOLD ON GOLD PLATED AREA, 3.81µM MATTE TIN LEAD ON TIN PLATE AREA. UNDER PLATING SHOULD BE 1.27µM NICKEL ON ENTIRE CONTACT.
- 11 FINISH: 0.03µM MIN GOLD ON GOLD PLATED AREA, 3.81µM MATTE TIN ON TIN PLATE AREA. UNDER PLATING SHOULD BE 1.27µM NICKEL ON ENTIRE CONTACT.
- 12. NOTE DELETED.
- 13. NOTE DELETED.
- 14 MATERIAL- HOUSING: LCP, COLOR: BLACK
POST: COPPER ALLOY

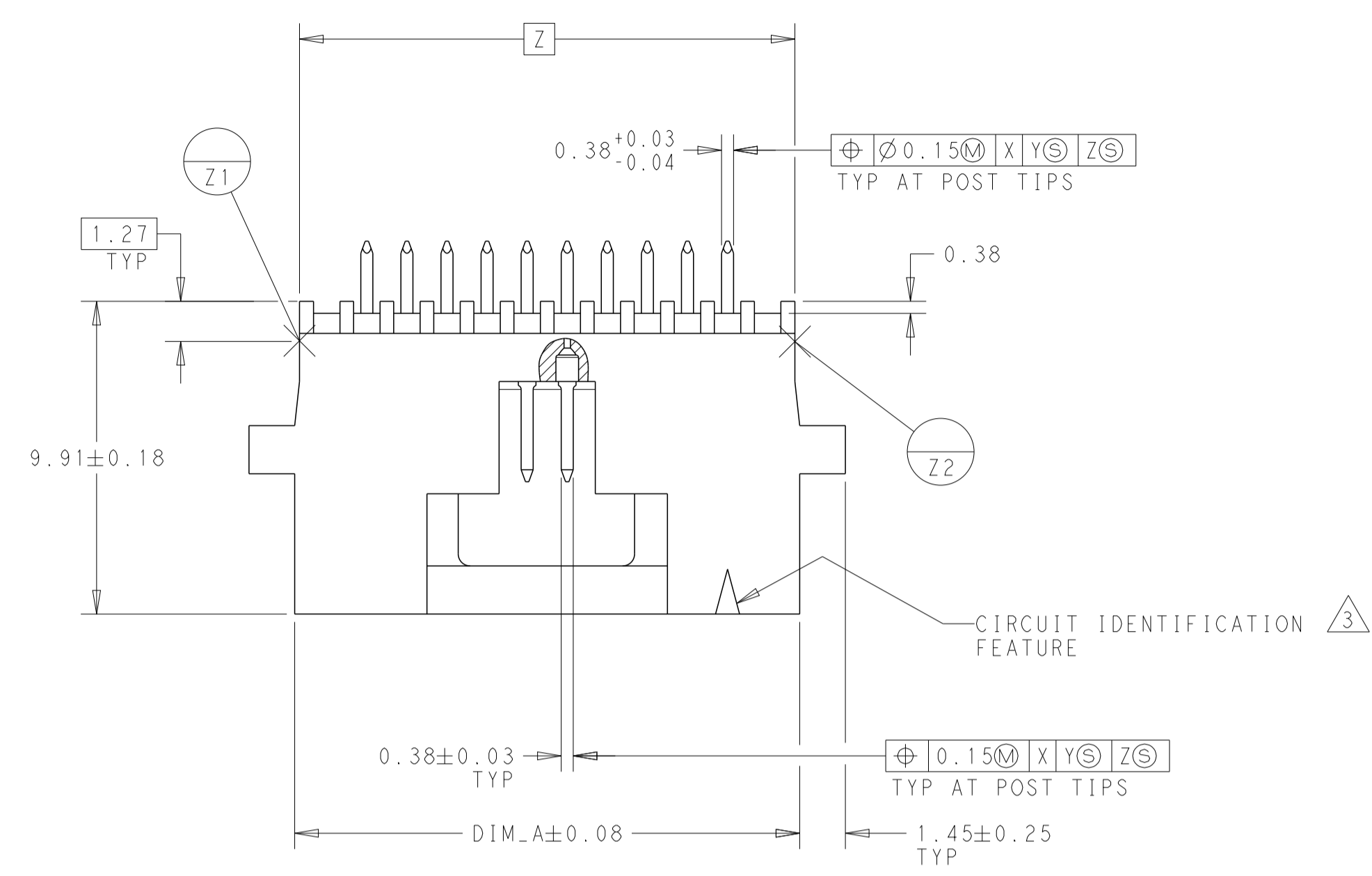
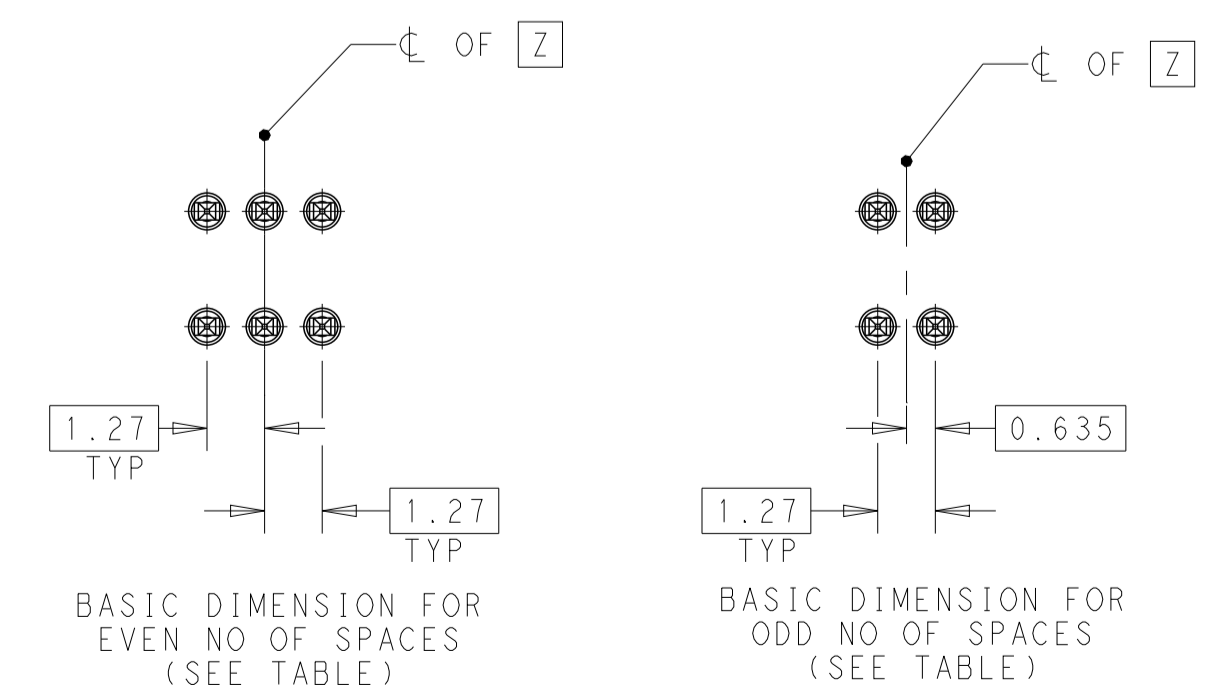
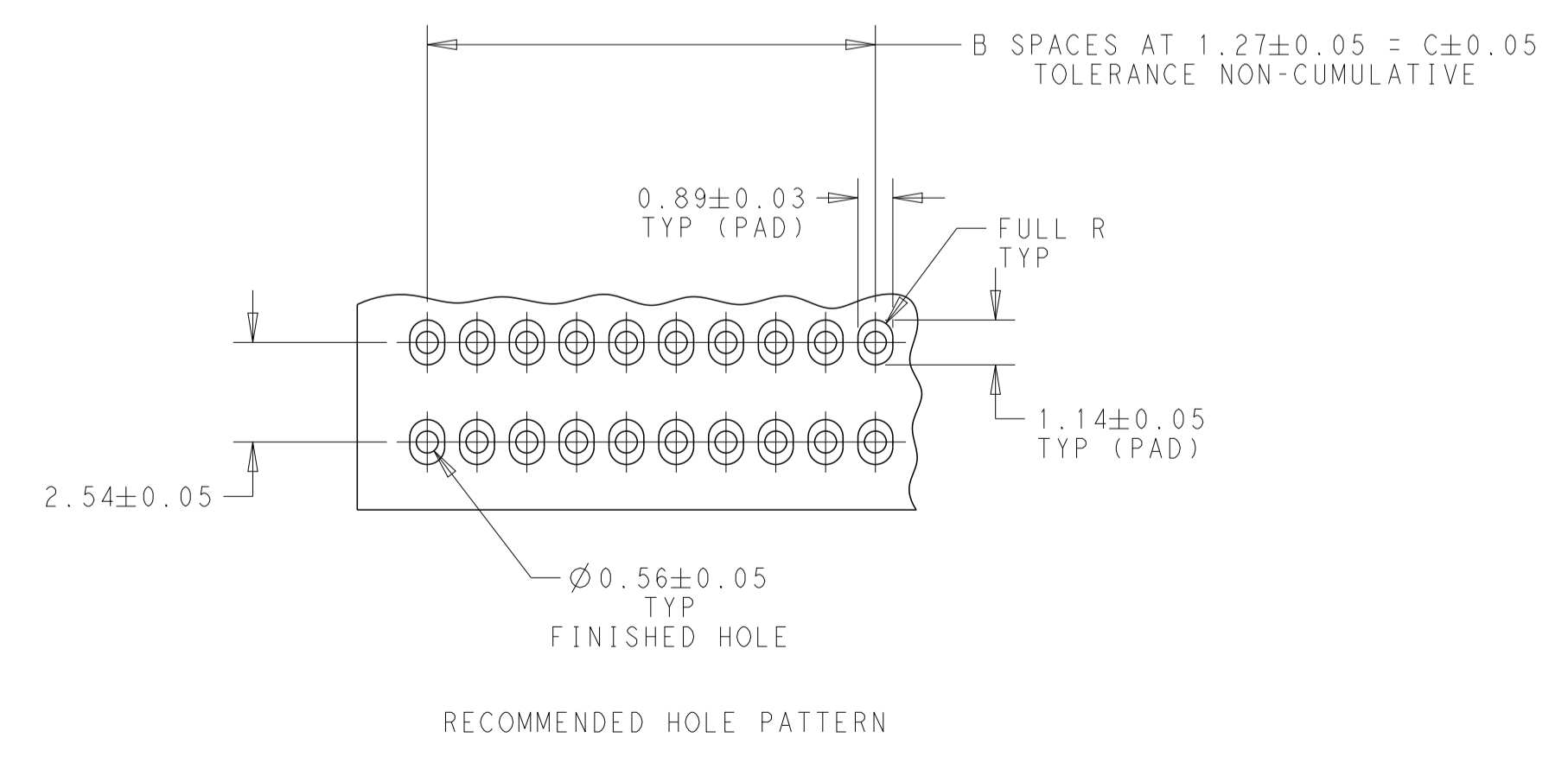
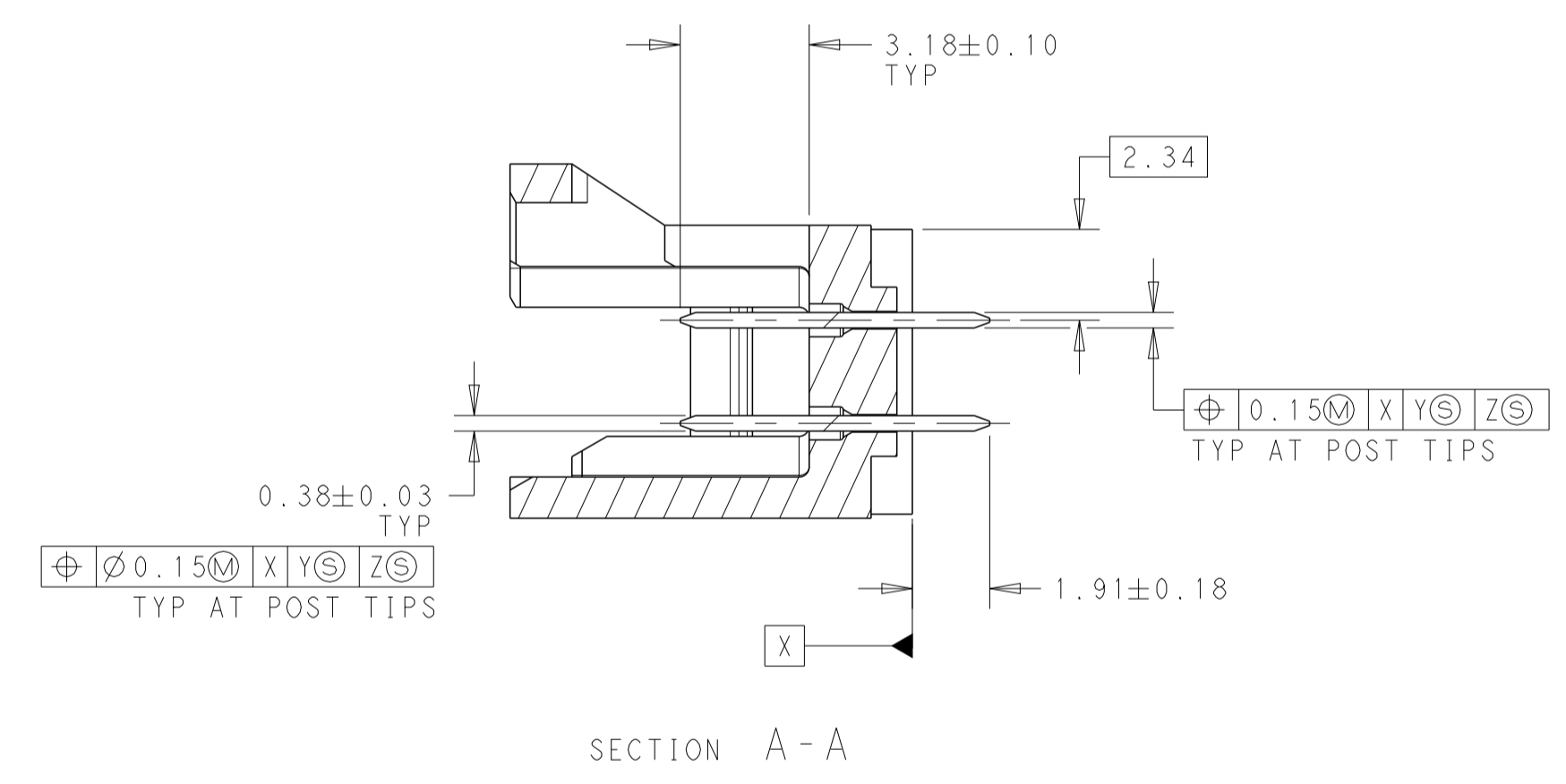
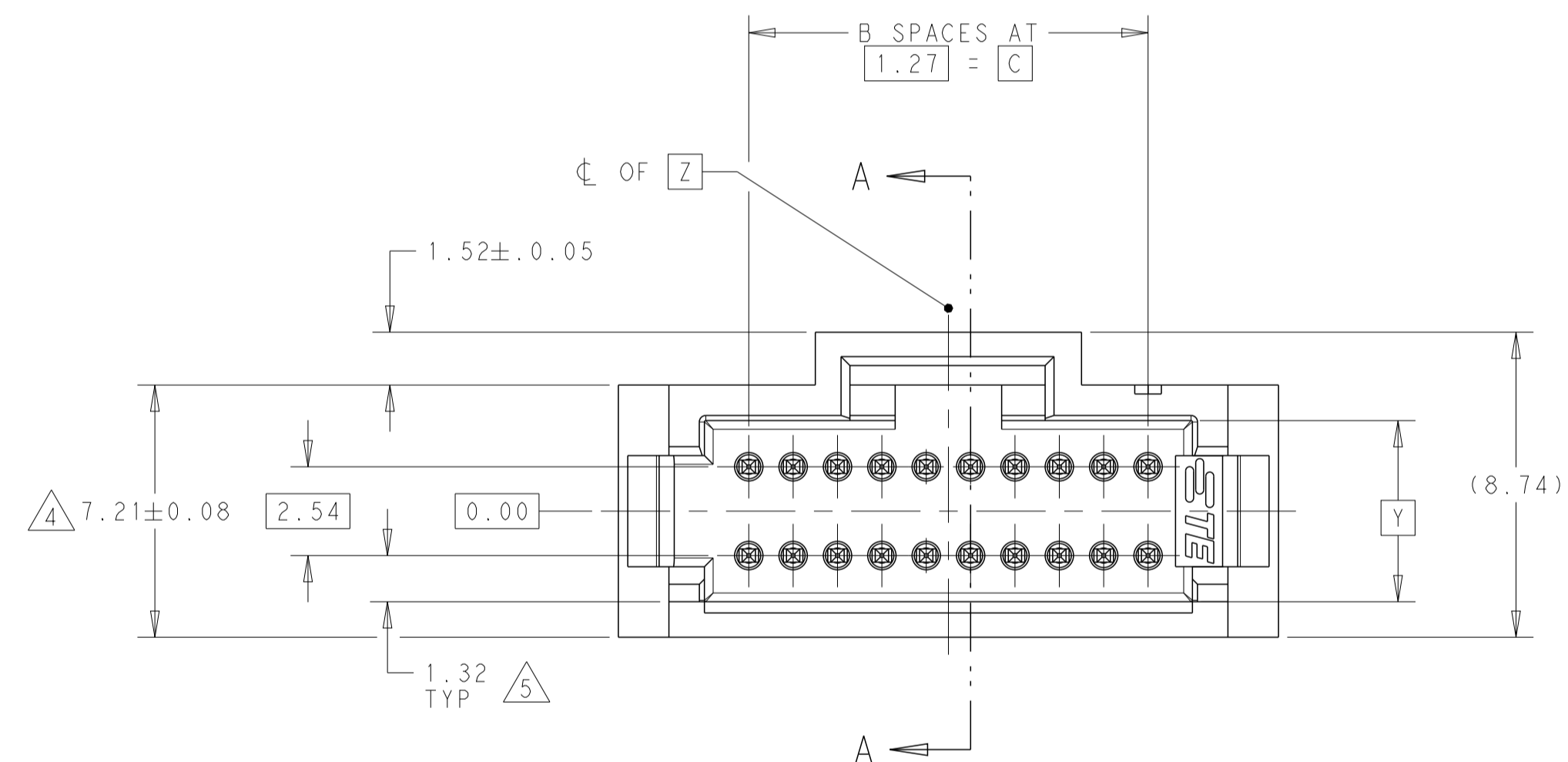

FINISH	DIM_C	B SPACES	DIM_A	NO OF POSN	PART NO
11	11.43	9	23.62	20	7-146397-3
	17.78	14	22.35	30	7-146397-2
	17.78	14	22.35	30	7-146397-1
9	11.43	9	23.62	20	5-146397-3
	17.78	14	22.35	30	5-146397-2
	17.78	14	22.35	30	5-146397-1

FINISH	DIM_C	B SPACES	DIM_A	NO OF POSN	PART NO
10	11.43	9	23.62	20	2-146397-3
	17.78	14	22.35	30	2-146397-2
	17.78	14	22.35	30	2-146397-1
1	11.43	9	23.62	20	146397-3
	17.78	14	22.35	30	146397-2
	17.78	14	22.35	30	146397-1

THIS DRAWING IS A CONTROLLED DOCUMENT.

DIMENSIONS:	TOLERANCES UNLESS OTHERWISE SPECIFIED:	OWN: R. SHRISHAILI 20NOV2017	NAME: HEADER ASSEMBLY, VERTICAL, SHROUDED DUAL ROW, W/SIDE AND END LATCHES
mm	0 PLC ±0.3 1 PLC ±0.3 2 PLC ±0.13 3 PLC ±0.13 4 PLC ±0.13	CHK: J. OLSON 20NOV2017	PRODUCT SPEC: 108-1093
	ANGLES ±0.5°	APVD: J. OLSON 20NOV2017	APPLICATION SPEC: 114-25031
MATERIAL:	SEE TABLE	SIZE: 114-25031	RESTRICTED TO: A100779C=146397
		WEIGHT: -	CUSTOMER DRAWING

SCALE: 6:1 SHEET 1 OF 1 REV E