

PRODUCT SPECIFICATION

Part Number	USB3105	Rev	B	Date	18/04/11		
Product Description	Micro USB Receptacle, Type AB, 5 Pin, TH, Vertical, with Through Hole Shell Stakes			Page	1		
Doc Number	USB3105	Prepared	SA	Checked	DR	Approved	LH

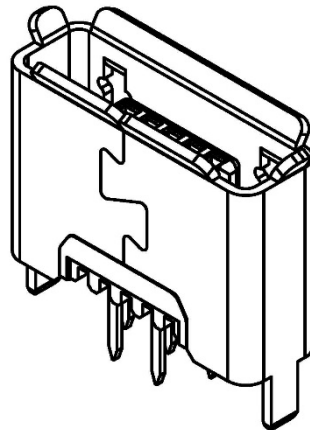

PRODUCT SPECIFICATION

Part Number	USB3105	Rev	B	Date	18/04/11
Product Description	Micro USB Receptacle, Type AB, 5 Pin, TH, Vertical, with Through Hole Shell Stakes			Page	2
Doc Number	USB3105	Prepared	SA	Checked	DR
				Approved	LH

1.0 SCOPE.

This specification covers performance, tests and quality requirements for the Micro USB Receptacle USB3105 (Type AB, 5-Pin, Through Hole, Vertical).

2.0 PRODUCT NAME AND PART NUMBER.

Micro USB Receptacle, 5 Pin, Type AB: USB3105.

3.0 PRODUCT SHAPE, DIMENSIONS AND MATERIAL.

Please refer to drawings.

4.0 RATINGS.

- 4.1 Current rating: Signal (Pins 2, 3, 4) 1.0A
- Power (Pins1, 5)..... 1.8A
- 4.2 Voltage rating 30 V
- 4.3 Operating Temperature Range -55°C to +85°C

5.0 TEST AND MEASUREMENT CONDITIONS.

Product is designed to meet electrical, mechanical and environmental performance requirements specified in Paragraph 6.0. All tests are performed in ambient conditions unless otherwise specified.

6.0 PERFORMANCE.

Item	Test Condition	Requirement
Examination of Product	Visual, dimensional and functional inspection as per quality plan.	Product shall meet requirements of product drawing and specification.

PRODUCT SPECIFICATION

Part Number	USB3105	Rev	B	Date	18/04/11
Product Description	Micro USB Receptacle, Type AB, 5 Pin, TH, Vertical, with Through Hole Shell Stakes			Page	3
Doc Number	USB3105	Prepared	SA	Checked	DR
		Approved	LH		

6.1 Electrical Performance.

Item	Test Condition	Requirement
Low-signal Level Contact Resistance	Subject mated contacts assembled in housing to 20mV Max open circuit at 100mA Max. In accordance with EIA-364-23.	30 mΩ Max.
Insulation Resistance	Mate/Un-mate connectors, apply 100V DC for 1 minute between adjacent terminal or ground. In accordance with EIA-364-21.	1000 MΩ Min.
Dielectric Withstanding Voltage	100V AC for 1minute. Test between adjacent circuits of unmated connector. In accordance with EIA-364-20.	No creeping discharge or flashover shall occur. Current leakage: 0.5 mA Max.

6.2 Mechanical Performance.

Item	Test Condition	Requirement
Mating Force	Operation Speed: 12.5 mm/min. Measure the force required to mate connector. In accordance with EIA-364-13.	35N Max.
Un-mating Force	Operation Speed: 12.5mm/min. Measure the force required to unmate connector. In accordance with EIA-364-13.	Initial: 10N Min. Final: 8N Min. 25N Max.
Durability	Operation Speed: 500 cycle/Hour (automatically) or 200 cycle/Hour (manual cycle) Durability Cycles: 10,000 Cycles In accordance with EIA-364-09.	Contact Resistance: 30 mΩ. Shall meet visual requirements, show no physical damage and meet requirement of additional tests.
Vibration	Subject mated connectors to 10-55-10 Hz traversed in 1minutes at 1.52mm amplitude 2 Hours each of 3 mutually perpendicular planes. 100mA Max. Applied. In accordance with EIA-364-28D.	No electrical discontinuity greater than 1μsec shall occur. Shall meet visual requirements, show no physical damage and meet requirement of additional tests.
Mechanical Shock	Accelerate Velocity: 30Gs Waveform: Half-sine shock plus Duration: 11msec Three shocks in each direction applied along three mutually perpendicular planes for a total of 18 shocks. In accordance with EIA-364-27.	No electrical discontinuity greater than 1μsec shall occur. Shall meet visual requirements, show no physical damage and meet requirement of additional tests.

PRODUCT SPECIFICATION

Part Number	USB3105	Rev	B	Date	18/04/11		
Product Description	Micro USB Receptacle, Type AB, 5 Pin, TH, Vertical, with Through Hole Shell Stakes				Page	4	
Doc Number	USB3105	Prepared	SA	Checked	DR	Approved	LH

6.3 Environmental Performance and Others.

Item	Test Condition	Requirement
Thermal Shock	Subject the mated connectors to 10 cycles between -55°C to +85°C. In accordance with EIA364-32, Test Condition I.	No evidence of mechanical or electric defects and shall meet visual requirements
Humidity Test	Mated Connector 40°C, 90~95% RH, 168 hours. In accordance with EIA-364-31.	Contact Resistance: 30 mΩ Max. Shall meet visual requirements, show no physical damage and meet requirement of additional tests.
Salt Spray	Subject mated connectors to 35+/-2°C and 5+/-1% salt condition for 48 hours. After test, rinse the sample with water and recondition the room temperature for 1 hour. In accordance with EIA-364-26.	No detrimental corrosion allowed in contact area and base metal exposed.
Temperature Life	Subject the mated connectors to temperature environment at +85°C for 500 hours. In accordance with EIA-364-17 Test Condition III, Method A.	No evidence of mechanical or electric defects and shall meet visual requirements.
Solderability	The inspected area of each lead must have 95% solder coverage minimum.	Solder pot temperature: 265 ±5°C, 5 sec.
Resistance to Soldering Heat	1. Reflow Solder Method: Pre-soak condition, 85°C/85% RH for 168 hours. Pre Heat: 150~180°C, 90+30sec. Heat: 230°C Min., 30+10sec. Peak Temp.:260+0/-5°C,20~40sec. Duration:3 cycles 2. Solder iron method: Solder temperature: 350 +/- 10 °C Immersion time: 3 +/- 1 second.	No physical damage shall occur. (Lead-Free.)

PRODUCT SPECIFICATION

Part Number	USB3105	Rev	B	Date	18/04/11		
Product Description	Micro USB Receptacle, Type AB, 5 Pin, TH, Vertical, with Through Hole Shell Stakes				Page	5	
Doc Number	USB3105	Prepared	SA	Checked	DR	Approved	LH

7.0 PRODUCT QUALIFICATION AND TEST SEQUENCE

Test Item	Test Group							
	A	B	C	D	E	F	G	H
Examination of Product	1, 9	1, 9	1, 4	1, 5	1, 9	1, 9	1, 3	1, 3
Contact Resistance	4, 8	3, 7		2, 4	4, 8	4, 8		
Dielectric Withstanding Voltage	3, 7				3, 7	3, 7		
Insulation Resistance	2, 6				2, 6	2, 6		
Mating Force		2, 6						
Unmating Force		4, 8						
Durability		5						
Vibration			2					
Mechanical Shock			3					
Solderability								2
Humidity						5		
Salt Spray				3				
Temperature Life	5							
Resistance to Soldering Heat							2	
Thermal Shock					5			

PRODUCT SPECIFICATION

Part Number	USB3105	Rev	B	Date	18/04/11		
Product Description	Micro USB Receptacle, Type AB, 5 Pin, TH, Vertical, with Through Hole Shell Stakes			Page	6		
Doc Number	USB3105	Prepared	SA	Checked	DR	Approved	LH

Revision details :-

Revision	Information	Page	Release Date
A	Specification Released.	-	18/04/11
B	New current rating.	4 and 5	17/10/11