

5P49V60

VersaClock® 6E Programmable Clock Generator

The 5P49V60 is a commercial, programmable clock generator supporting automotive applications. Configurations may be stored in on-chip One-Time Programmable (OTP) memory or changed using I2C interface. This is Renesas' sixth generation of programmable clock technology (VersaClock 6E).

The frequencies are generated from a single reference clock. The reference clock can come from one of the two redundant clock inputs. A glitchless manual switchover function allows one of the redundant clocks to be selected during normal operation.

Two select pins allow up to four different configurations to be programmed and accessible using processor GPIOs or bootstrapping. The different selections may be used for different operating modes (full function, partial function, partial power-down), regional standards (US, Japan, Europe) or system production margin testing. The device may be configured to use one of two I²C addresses to allow multiple devices to be used in a system.

Applications

- Automotive infotainment
- Dashboard systems
- PCI Express 1.0 / 2.0 / 3.0 / 4.0 (with spread spectrum)
- Audio/Video applications
- Camera applications
- Active antennas
- In-vehicle networking

Features

- Flexible 1.8V, 2.5V, or 3.3V power-rails
- High-performance, low phase noise PLL, < 0.5ps RMS typical phase jitter on outputs
- Four banks of internal OTP memory
 - In-system or factory programmable
 - Two select pins accessible with processor GPIOs or bootstrapping
- I²C serial programming interface
 - 0xD0 or 0xD4 I2C address options allows multiple devices configured in a same system
- Reference LVCMOS output clock
- Four universal output pairs individually configurable:
 - Differential (LVPECL, LVDS or HCSL)
 - Two single-ended (2 LVCMOS in-phase or 180 degrees out of phase)
 - I/O V_{DD}'s can be mixed and matched, supporting 1.8V (LVDS and LVCMOS), 2.5V, or 3.3V
- Output frequency ranges:
 - LVCMOS clock outputs: 1MHz to 200MHz
 - LVDS, LVPECL, HCSL differential clock outputs: 1MHz to 350MHz
- Redundant clock input with manual switchover
- Programmable output enable or power-down mode
- 4 × 4 mm 24-VFQFPN wettable flank package
- AEC-Q100 qualified
- -40°C to +105°C (Grade 2 equivalent) operating temperature

Contents

1. Overview	3
1.1 Block Diagram	3
2. Pin Information	4
2.1 Pin Assignments	4
2.2 Pin Descriptions	4
3. Specifications	6
3.1 Absolute Maximum Ratings	6
3.2 ESD Ratings	6
3.3 Recommended Operating Conditions	6
3.4 Thermal Specifications	6
3.5 Electrical Specifications	7
4. I2C Bus Characteristics	11
5. Test Loads	12
6. Jitter Performance Characteristics	13
6.1 PCI Express Jitter Performance and Specifications	14
7. Features and Functional Blocks	14
7.1 Device Startup and Power-On-Reset	14
7.2 Reference Clock and Selection	15
7.3 Manual Switchover	15
7.4 Internal Crystal Oscillator (XIN/REF)	16
7.4.1 Choosing Crystals	16
7.4.2 Tuning the Crystal Load Capacitor	16
7.5 Programmable Loop Filter	17
7.6 Fractional Output Dividers (FOD)	18
7.6.1 Individual Spread Spectrum Modulation	18
7.6.2 Bypass Mode	18
7.6.3 Dividers Alignment	18
7.6.4 Programmable Skew	18
7.7 Output Drivers	18
7.8 SD/OE Pin Function	19
7.9 I2C Operation	20
8. Typical Application Circuit	21
8.1 Input – Driving the XIN/REF or CLKIN	22
8.1.1 Driving XIN/REF with a CMOS Driver	22
8.1.2 Driving XIN with an LVPECL Driver	22
8.1.3 Wiring the CLKIN Pin to Accept Single-ended Inputs	23
8.1.4 Driving CLKIN with Differential Clock	23
8.2 Output – Single-ended or Differential Clock Terminations	24
8.2.1 LVDS Termination	24
8.2.2 LVPECL Termination	24
8.2.3 HCSL Termination	26
8.2.4 LVCMOS Termination	27
9. Package Outline Drawings	28
10. Marking Diagram	28

11. Ordering Information 28
 12. Revision History 28

1. Overview

1.1 Block Diagram

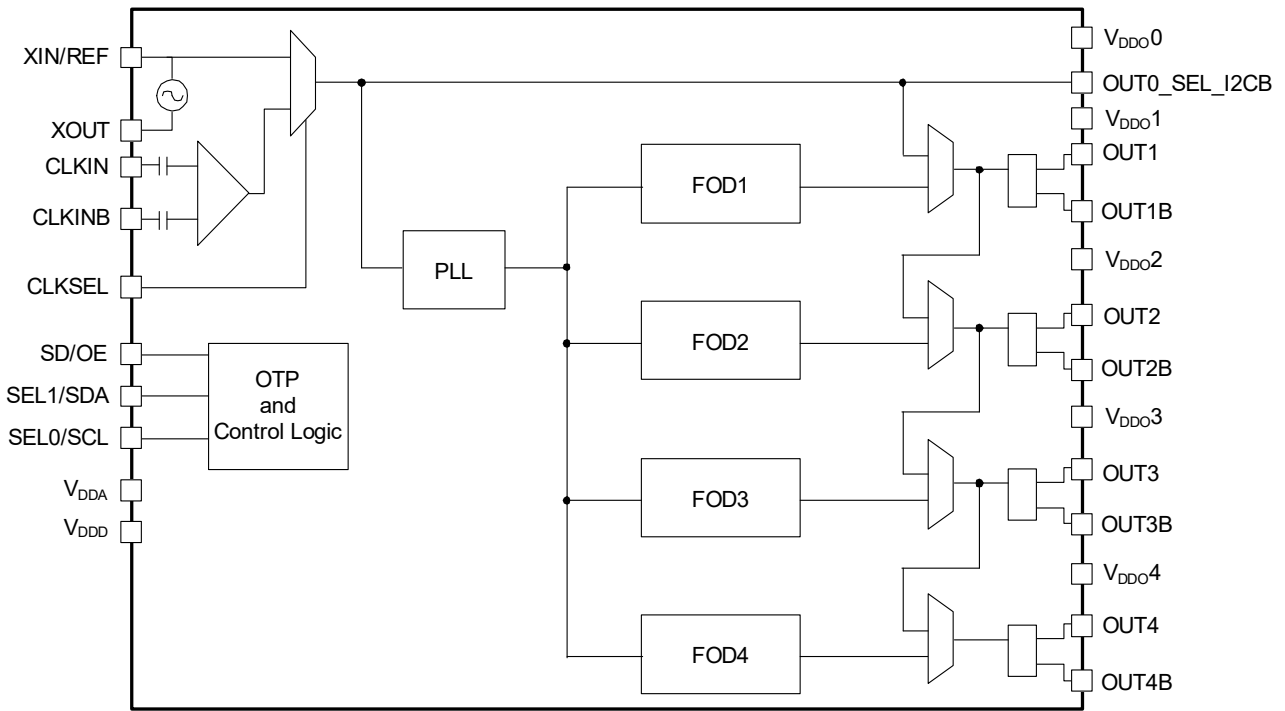

2. Pin Information

2.1 Pin Assignments

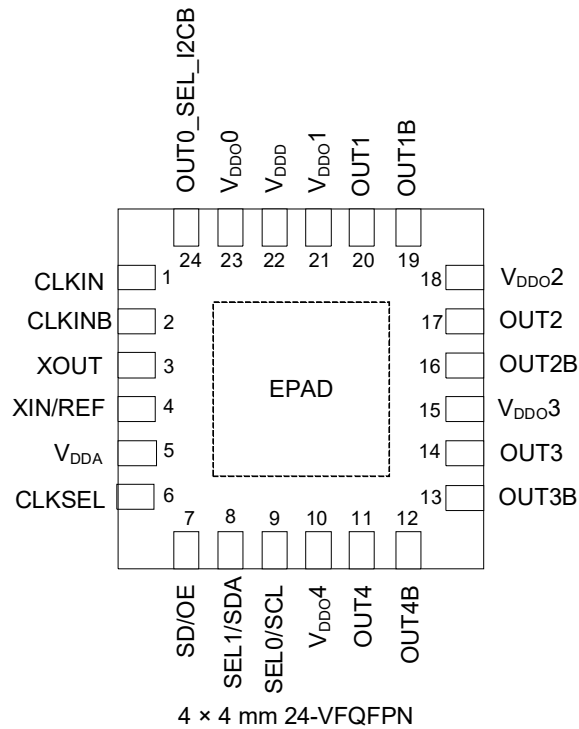

Figure 1. Pin Assignments for 4 × 4 mm 24-VFQFPN Package – Top View

2.2 Pin Descriptions

Pin Number	Pin Name	Pin Type		Description
1	CLKIN	Input	Internal Pull-down	Differential clock input. Weak 100kΩ internal pull-down.
2	CLKINB	Input	Internal Pull-down	Complementary differential clock input. Weak 100kΩ internal pull-down.
3	XOUT	Output		Crystal oscillator interface output.
4	XIN/REF	Input		Crystal oscillator interface input, or single-ended LVCMOS clock input. Ensure that the input voltage is between 500mV and 1.2V. Refer to the section Driving XIN/REF with a CMOS Driver .
5	V _{DDA}	Power		Analog functions power supply pin. Connect to 1.8V to 3.3V. V _{DDA} and V _{DDO} should have the same voltage applied.
6	CLKSEL	Input	Internal Pull-down	Input clock select. Selects the active input reference source in manual switchover mode. 0 = XIN/REF, XOUT (default). 1 = CLKIN, CLKINB. See Table 16 for more details.
7	SD/OE	Input	Internal Pull-down	Enables/disables the outputs (OE) or powers down the chip (SD).
8	SEL1/SDA	Input	Internal Pull-down	Configuration select pin, or I ² C SDA input as selected by OUT0_SEL_I2CB. Weak internal pull-down resistor.

Pin Number	Pin Name	Pin Type		Description
9	SEL0/SCL	Input	Internal Pull-down	Configuration select pin, or I ² C SCL input as selected by OUT0_SEL_I2CB. Weak internal pull-down resistor.
10	V _{DDO4}	Power		Output power supply. Connect to 1.8 to 3.3V. Sets output voltage levels for OUT4/OUT4B.
11	OUT4	Output		Output clock 4. Refer to the Output Drivers section for more details.
12	OUT4B	Output		Complementary output clock 4. Refer to the Output Drivers section for more details.
13	OUT3B	Output		Complementary output clock 3. Refer to the Output Drivers section for more details.
14	OUT3	Output		Output clock 3. Refer to the Output Drivers section for more details.
15	V _{DDO3}	Power		Output power supply. Connect to 1.8 to 3.3V. Sets output voltage levels for OUT3/OUT3B.
16	OUT2B	Output		Complementary output clock 2. Refer to the Output Drivers section for more details.
17	OUT2	Output		Output clock 2. Refer to the Output Drivers section for more details.
18	V _{DDO2}	Power		Output power supply. Connect to 1.8 to 3.3V. Sets output voltage levels for OUT2/OUT2B.
19	OUT1B	Output		Complementary output clock 1. Refer to the Output Drivers section for more details.
20	OUT1	Output		Output clock 1. Refer to the Output Drivers section for more details.
21	V _{DDO1}	Power		Output power supply. Connect to 1.8 to 3.3V. Sets output voltage levels for OUT1/OUT1B.
22	V _{DDD}	Power		Digital functions power supply pin. Connect to 1.8 to 3.3V. V _{DDA} and V _{DDD} should have the same voltage applied.
23	V _{DDO0}	Power		Power supply pin for OUT0_SEL_I2CB. Connect to 1.8 to 3.3V. Sets output voltage levels for OUT0.
24	OUT0_SEL_I2CB	Input/Output	Internal Pull-down	Latched input/LVCMOS output. At power-up, the voltage at the pin OUT0_SEL_I2CB is latched by the part and used to select the state of pins 8 and 9. If a weak pull-up (10kΩ) is placed on OUT0_SEL_I2CB, pins 8 and 9 will be configured as hardware select pins, SEL1 and SEL0. If a weak pull-down (10kΩ) is placed on OUT0_SEL_I2CB or it is left floating, pins 8 and 9 will act as the SDA and SCL pins of an I ² C interface. After power-up, the pin acts as an LVCMOS reference output.
25	GND	GND		Connect to ground pad.

3. Specifications

3.1 Absolute Maximum Ratings

CAUTION: Do not operate at or near the maximum ratings listed for extended periods of time. Exposure to such conditions can adversely impact product reliability and result in failures not covered by warranty.

Table 1. Absolute Maximum Ratings

Item	Rating
Supply Voltage, V_{DDA} , V_{DDD} , V_{DDO}	3.465V
XIN/REF Input	1.2V
CLKIN, CLKINB Input	V_{DDO0} , 1.2V voltage swing
I ² C Loading Current	10mA
Storage Temperature, T_{STG}	-65°C to 150°C

3.2 ESD Ratings

ESD Model/Test	Rating	Unit
Human Body Model (Tested per JS-001-2017)	2000	V

3.3 Recommended Operating Conditions

Symbol	Parameter	Minimum	Typical	Maximum	Unit
V_{DDOX}	Power supply voltage for supporting 1.8V outputs.	1.71	1.8	1.89	V
	Power supply voltage for supporting 2.5V outputs.	2.375	2.5	2.625	V
	Power supply voltage for supporting 3.3V outputs.	3.135	3.3	3.465	V
V_{DDD}	Power supply voltage for core logic functions.	1.71	-	3.465	V
V_{DDA}	Analog power supply voltage. Use filtered analog power supply.	1.71	-	3.465	V
T_A	Operating temperature (Grade 2), ambient.	-40	-	105	°C
C_L	Maximum load capacitance (3.3V LVCMOS only).	-	-	15	pF
t_{PU}	Power-up time for all V_{DDs} to reach minimum specified voltage (power ramps must be monotonic).	0.05	-	5	ms

3.4 Thermal Specifications

Symbol	Parameter	Value	Unit
θ_{JA}	Theta J_A . Junction to air thermal impedance (0mps).	42	°C/W
θ_{JB}	Theta J_B . Junction to board thermal impedance (0mps).	2.35	°C/W
θ_{JC}	Theta J_C . Junction to case thermal impedance (0mps).	41.8	°C/W

3.5 Electrical Specifications

Recommended operating conditions unless otherwise noted. V_{DDA} , V_{DDD} , V_{DDO0} = 3.3V \pm 5%, 2.5V \pm 5%, 1.8V \pm 5%, T_A = -40°C to +105°C, unless otherwise specified.

Table 2. Current Consumption

Symbol	Parameter	Conditions	Minimum	Typical	Maximum	Unit
I_{DDCORE} [1]	Core Supply Current	100MHz on all outputs, 25MHz REFCLK (3.3V)	-	32	42	mA
		100MHz on all outputs, 25MHz REFCLK (2.5V)	-	32	42	
		100MHz on all outputs, 25MHz REFCLK (1.8V)	-	31	42	
I_{DDOx}	Output Buffer Supply Current	LVPECL, 350MHz, 3.3V V_{DDOx} .	-	48	63	mA
		LVPECL, 350MHz, 2.5V V_{DDOx} .	-	41	54	mA
		LVDS, 350MHz, 3.3V V_{DDOx} .	-	26	32	mA
		LVDS, 350MHz, 2.5V V_{DDOx} (same setting as 3.3V).	-	25	30	mA
		LVDS, 350MHz, 1.8V V_{DDOx} .	-	23	27	mA
		HCSL, 250MHz, 3.3V V_{DDOx} . [2]	-	39	48	mA
		HCSL, 250MHz, 2.5V V_{DDOx} . [2]	-	37	46	mA
		LVC MOS, 50MHz, 3.3V, V_{DDOx} . [2][3]	-	23	27	mA
		LVC MOS, 50MHz, 2.5V, V_{DDOx} . [2][3]	-	20	24	mA
		LVC MOS, 50MHz, 1.8V, V_{DDOx} . [2][3]	-	18	21	mA
		LVC MOS, 200MHz, 3.3V V_{DDOx} . [2][3]	-	45	58	mA
		LVC MOS, 200MHz, 2.5V V_{DDOx} . [2][3]	-	34	45	mA
LVC MOS, 200MHz, 1.8V V_{DDOx} . [2][3]	-	24	33	mA		
I_{DDPD}	Power Down Current	SD asserted, I ² C programming (3.3V).	-	10	12	mA
		SD asserted, I ² C programming (2.5V).	-	10	12	
		SD asserted, I ² C programming (1.8V).	-	10	12	

1. I_{DDCORE} = I_{DDA} + I_{DDD} , no loads.
2. Measured into a 5" 50Ω trace with 2pF load.
3. Single CMOS driver active.

Table 3. AC Timing Characteristics

Symbol	Parameter	Conditions	Minimum	Typical	Maximum	Unit
$f_{IN}^{[1]}$	Input Frequency	Input frequency limit (crystal).	8	-	40	MHz
		Input frequency limit (CLKIN,CLKINB).	1	-	350	MHz
		Input frequency limit (single-ended over XIN).	1	-	200	MHz
$f_{OUT}^{[2]}$	Output Frequency	Single-ended clock output limit (LVCMOS).	1	-	200	MHz
		Differential clock output limit (LVPECL/LVDS/HCSL).	1	-	350	
$t_{DC}^{[3]}$	Output Duty Cycle	Measured at $V_{DD}/2$, all outputs except reference output, $V_{DDOX} = 2.5V$ or $3.3V$.	45	50	55	%
		Measured at $V_{DD}/2$, all outputs except reference output, $V_{DDOX} = 1.8V$.	40	50	60	%
		Measured at $V_{DD}/2$, reference output OUT0 (5MHz–150.1MHz) with 50% duty cycle input.	40	50	60	%
		Measured at $V_{DD}/2$, reference output OUT0 (150.1MHz–200MHz) with 50% duty cycle input.	30	50	70	%
t_{SKEW}	Output Skew	Skew between the same frequencies, with outputs using the same driver format and phase delay set to 0ns.	-	75	-	ps
$t_{STARTUP}^{[4][5]}$	Startup Time	Measured after all V_{DD} s have risen above 90% of their target value. ^[6]	-	-	30	ms
		PLL lock time from shutdown mode.	-	3	4	ms

1. Practical lower frequency is determined by loop filter settings.
2. A slew rate of 2.75V/ns or greater should be selected for output frequencies of 100MHz or higher.
3. Duty cycle is only guaranteed at maximum slew rate settings.
4. Actual PLL lock time depends on the loop configuration.
5. Includes loading the configuration bits from EPROM to PLL registers. It does not include EPROM programming/write time.
6. Power-up with temperature calibration enabled; contact Renesas if shorter lock-time is required in system.

Table 4. Input Characteristics

Symbol	Parameter	Conditions	Minimum	Typical	Maximum	Unit
C_{IN}	Input Capacitance	CLKIN,CLKINB,CLKSEL,SD/OE,SEL1/SDA,SEL0/SCL.	-	3	7	pF
R_{PD}	Pull-down Resistor	CLKSEL, SD/OE, SEL1/SDA, SEL0/SCL, CLKIN, CLKINB, OUT0_SEL_I2CB.	100	-	350	k Ω
V_{IH}	Input High Voltage	CLKSEL, SD/OE.	$0.7 \times V_{DDD}$	-	$V_{DDD} + 0.3$	V
V_{IL}	Input Low Voltage	CLKSEL, SD/OE. $V_{DDA}, V_{DDD}, V_{DDO0} = 3.3V$ and $2.5V$.	GND - 0.3	-	$0.3 \times V_{DDD}$	V
		CLKSEL, SD/OE. $V_{DDA}, V_{DDD}, V_{DDO0} = 1.8V$.	GND - 0.3	-	0.4	V
V_{IH}	Input High Voltage	OUT0_SEL_I2CB.	$0.7 \times V_{DDO}$	-	$V_{DDO0} + 0.3$	V
V_{IL}	Input Low Voltage	OUT0_SEL_I2CB.	GND - 0.3	-	0.4	V
V_{IH}	Input High Voltage	XIN/REF.	0.5	-	1.2	V

Table 4. Input Characteristics (Cont.)

Symbol	Parameter	Conditions	Minimum	Typical	Maximum	Unit
V _{IL}	Input Low Voltage	XIN/REF.	GND - 0.3	-	0.4	V
T _R /T _F	Input Rise/Fall Time	CLKSEL, SD/OE, SEL1/SDA, SEL0/SCL.	-	-	300	ns

Table 5. CLKIN Electrical Characteristics

Symbol	Parameter	Conditions	Minimum	Typical	Maximum	Unit
V _{SWING}	Input Amplitude – CLKIN, CLKINB	Peak to peak value, single-ended.	200	-	1200	mV
dv/dt	Input Slew Rate – CLKIN, CLKINB	Measured differentially.	0.4	-	8	V/ns
I _{IL}	Input Leakage Low Current	V _{IN} = GND.	-5	-	5	μA
I _{IH}	Input Leakage High Current	V _{IN} = 1.7V.	-	-	30	μA
DC _{IN}	Input Duty Cycle	Measurement from differential waveform.	45	-	55	%

Table 6. Electrical Characteristics – CMOS Outputs

Symbol	Parameter	Conditions	Minimum	Typical	Maximum	Unit
V _{OH}	Output High Voltage	I _{OH} = -15mA (3.3V), -12mA (2.5V), -8mA (1.8V). V _{DDA} , V _{DDD} , V _{DDO0} = 3.3V and 2.5V. V _{DDA} , V _{DDD} , V _{DDO0} = 1.8V.	0.7 x V _{DDO} 0.5 x V _{DDO}	-	V _{DDO} V _{DDO}	V
V _{OL}	Output Low Voltage	I _{OL} = 15mA (3.3V), 12mA (2.5V), 8mA (1.8V).	-	-	0.45	V
R _{OUT}	Output Driver Impedance	CMOS output driver.	-	17	-	Ω
T _{SR}	Slew Rate, SLEW[1:0] = 00	Single-ended 3.3V LVCMOS output clock rise and fall time, 20% to 80% of V _{DDO} (output load = 5pF) V _{DDOX} = 3.3V.	1.0	2.2	-	V/ns
	Slew Rate, SLEW[1:0] = 01		1.2	2.3	-	
	Slew Rate, SLEW[1:0] = 10		1.3	2.4	-	
	Slew Rate, SLEW[1:0] = 11		1.7	2.7	-	
	Slew Rate, SLEW[1:0] = 00	Single-ended 2.5V LVCMOS output clock rise and fall time, 20% to 80% of V _{DDO} (output load = 5pF) V _{DDOX} = 2.5V.	0.6	1.3	-	
	Slew Rate, SLEW[1:0] = 01		0.7	1.4	-	
	Slew Rate, SLEW[1:0] = 10		0.6	1.4	-	
	Slew Rate, SLEW[1:0] = 11		1.0	1.7	-	
	Slew Rate, SLEW[1:0] = 00	Single-ended 1.8V LVCMOS output clock rise and fall time, 20% to 80% of V _{DDO} (output load = 5pF) V _{DD} = 1.8V.	0.3	0.7	-	
	Slew Rate, SLEW[1:0] = 01		0.4	0.8	-	
	Slew Rate, SLEW[1:0] = 10		0.4	0.9	-	
	Slew Rate, SLEW[1:0] = 11		0.7	1.2	-	
I _{OZDD}	Output Leakage Current (OUT1–4)	Tri-state outputs.	-	-	5	μA
	Output Leakage Current (OUT0)	Tri-state outputs.	-	-	30	μA

Table 7. Electrical Characteristics – LVDS Outputs

Symbol	Parameter	Minimum	Typical	Maximum	Unit
$V_{OT (+)}$	Differential Output Voltage for the TRUE Binary State	247	-	454	mV
$V_{OT (-)}$	Differential Output Voltage for the FALSE Binary State	-454	-	-247	mV
ΔV_{OT}	Change in V_{OT} between Complimentary Output States	-	-	50	mV
V_{OS}	Output Common Mode Voltage (Offset Voltage) at 3.3 V $\pm 5\%$, 2.5V $\pm 5\%$	1.125	1.25	1.375	V
	Output Common Mode Voltage (Offset Voltage) at 1.8V $\pm 5\%$	0.8	0.875	0.96	V
ΔV_{OS}	Change in V_{OS} between Complimentary Output States	-	-	50	mV
I_{OS}	Outputs Short Circuit Current, V_{OUT+} or $V_{OUT-} = 0V$ or V_{DDO}	-	9	24	mA
I_{OSD}	Differential Outputs Short Circuit Current, $V_{OUT+} = V_{OUT-}$	-	6	12	mA
T_R	LVDS rise time 20%–80%	-	300	-	ps
T_F	LVDS fall time 80%–20%	-	300	-	ps

Table 8. Electrical Characteristics – LVPECL Outputs

Symbol	Parameter	Minimum	Typical	Maximum	Unit
V_{OH}	Output Voltage High, Terminated through 50 Ω tied to $V_{DD} - 2V$	$V_{DDO} - 1.19$	-	$V_{DDO} - 0.69$	V
V_{OL}	Output Voltage Low, Terminated through 50 Ω tied to $V_{DD} - 2V$	$V_{DDO} - 1.94$	-	$V_{DDO} - 1.4$	V
V_{SWING}	Peak-to-Peak Output Voltage Swing	0.55	-	0.993	V
T_R	LVPECL rise time 20%–80%	-	400	-	ps
T_F	LVPECL fall time 80%–20%	-	400	-	ps

Table 9. Electrical Characteristics – HCSL Outputs [1]

Symbol	Parameter	Conditions	Minimum	Typical	Maximum	Unit
dV/dt	Slew Rate	Scope averaging on. [2][3]	1	-	4	V/ns
$\Delta dV/dt$	Slew Rate Matching	Scope averaging on. [3]	-	-	20	%
V_{MAX}	Maximum Voltage	Measurement on single-ended signal using absolute value (scope averaging off).	-	-	1150	mV
V_{MIN}	Minimum Voltage		-300	-	-	mV
V_{SWING}	Voltage Swing	Scope averaging off. [2][4]	300	-	-	mV
V_{CROSS}	Crossing Voltage Value	Scope averaging off. [4][5]	250	-	550	mV
ΔV_{CROSS}	Crossing Voltage Variation	Scope averaging off. [6]	-	-	140	mV

1. Confirmed by design and characterization. Not 100% tested in production.
2. Measured from differential waveform.
3. Slew rate is measured through the V_{SWING} voltage range centered around differential 0V. This results in a $\pm 150mV$ window around differential 0V.
4. Measured from single-ended waveform.
5. V_{CROSS} is defined as voltage where Clock = Clock# measured on a component test board and only applies to the differential rising edge (i.e. Clock rising and Clock# falling).
6. The total variation of all V_{CROSS} measurements in any particular system. Note that this is a subset of V_{CROSS} min/max (V_{CROSS} absolute) allowed. The intent is to limit V_{CROSS} induced modulation by setting ΔV_{CROSS} to be smaller than V_{CROSS} absolute.

Table 10. Spread Spectrum Generation Specifications

Symbol	Parameter	Conditions	Minimum	Typical	Maximum	Unit
f_{SSOUT}	Spread Frequency	Output frequency range for spread spectrum.	5	-	300	MHz
f_{MOD}	Mod Frequency	Modulation frequency.	30 to 63			kHz
f_{SPREAD}	Spread Value	Amount of spread value (programmable)–center spread.	$\pm 0.25\%$ to $\pm 2.5\%$			$\%f_{OUT}$
		Amount of spread value (programmable)–down spread.	-0.5% to -5%			

4. I²C Bus Characteristics

Table 11. I²C Bus DC Characteristics(3.3V $\pm 5\%$ only.)

Symbol	Parameter	Conditions	Minimum	Typical	Maximum	Unit
V_{IH}	Input High Level	For SEL1/SDA pin and SEL0/SCL pin.	$0.7 \times V_{DDD}$	-	-	V
V_{IL}	Input Low Level	For SEL1/SDA pin and SEL0/SCL pin.	-	-	$0.3 \times V_{DDD}$	V
V_{HYS}	Hysteresis of Inputs	-	$0.05 \times V_{DDD}$	-	-	V
I_{IN}	Input Leakage Current	-	-	-	36	μA
V_{OL}	Output Low Voltage	$I_{OL} = 3mA$.	-	-	0.45	V

Table 12. I²C Bus AC Characteristics [1]

Symbol	Parameter	Conditions	Minimum	Typical	Maximum	Unit
F_{SCLK}	Serial Clock Frequency (SCL)	-	10	-	400	kHz
t_{BUF}	Bus Free Time between Stop and Start	-	1.3	-	-	μs
$t_{SU:START}$	Setup Time, Start	-	0.6	-	-	μs
$t_{HD:START}$	Hold Time, Start	-	0.6	-	-	μs
$t_{SU:DATA}$	Setup Time, Data Input (SDA)	-	0.1	-	-	μs
$t_{HD:DATA}$	Hold Time, Data Input (SDA) [2]	-	0	-	-	μs
t_{OVD}	Output Data Valid from Clock	-	-	-	0.9	μs
C_B	Capacitive Load for Each Bus Line	-	-	-	400	pF
t_R	Rise Time, Data and Clock (SDA, SCL)	-	$20 + 0.1 \times C_B$	-	300	ns
t_F	Fall Time, Data and Clock (SDA, SCL)	-	$20 + 0.1 \times C_B$	-	300	ns
t_{HIGH}	High Time, Clock (SCL)	-	0.6	-	-	μs
t_{LOW}	Low Time, Clock (SCL)	-	1.3	-	-	μs
$t_{SU:STOP}$	Setup Time, Stop	-	0.6	-	-	μs

- I²C inputs are 5V tolerant.
- A device must internally provide a hold time of at least 300ns for the SDA signal (referred to the $V_{IH(MIN)}$ of the SCL signal) to bridge the undefined region of the falling edge of SCL.

5. Test Loads

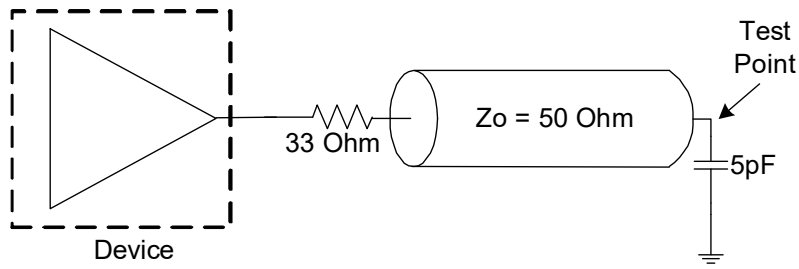

Figure 2. LVC MOS Test Load

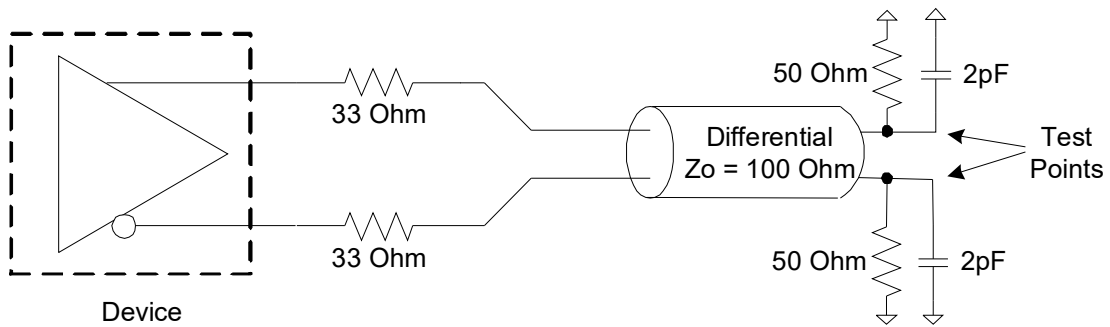

Figure 3. HCSL Test Load

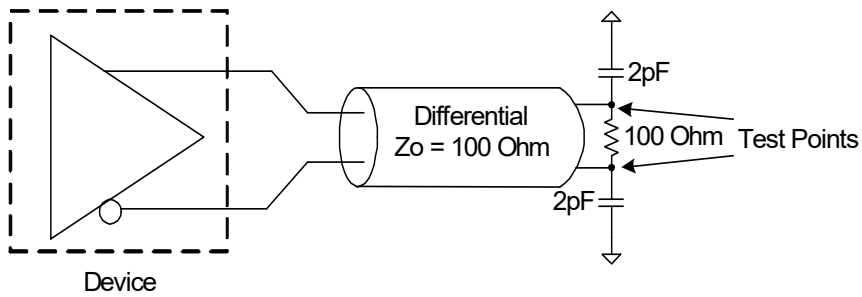

Figure 4. LVDS Test Load

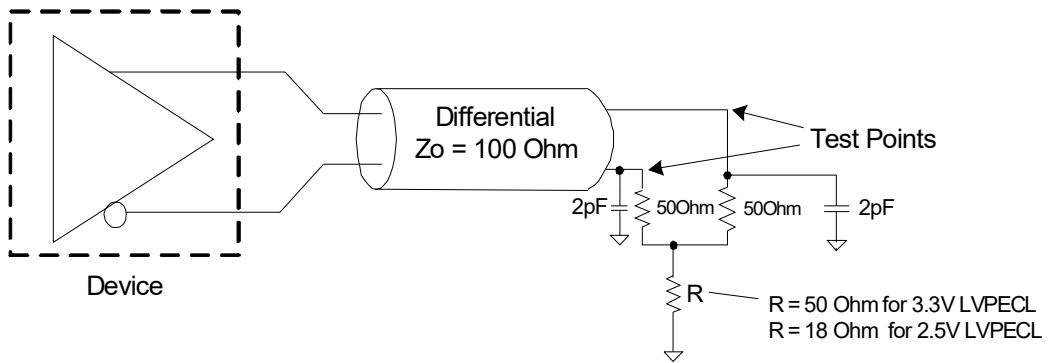
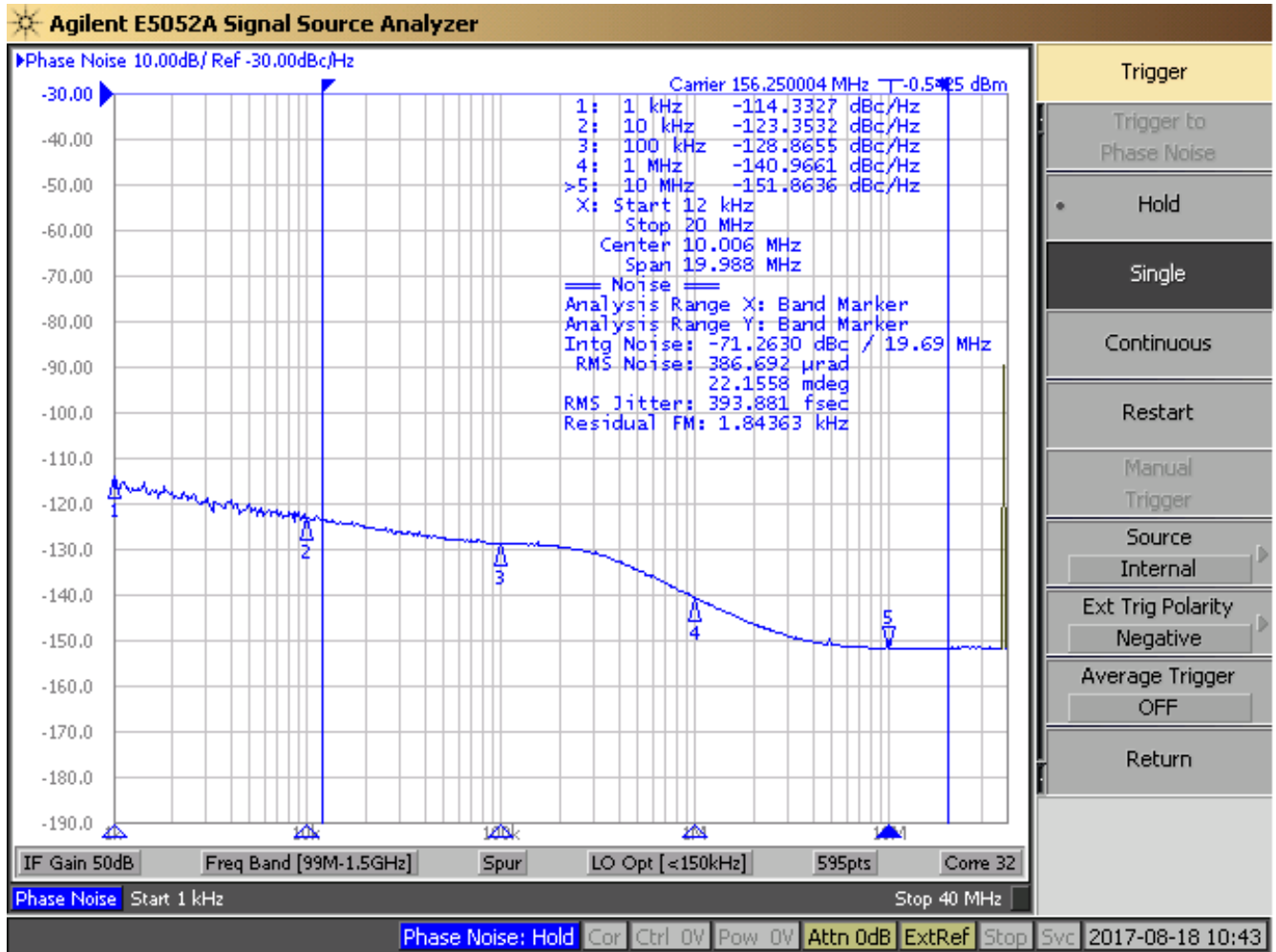

Figure 5. LVPECL Test Load

6. Jitter Performance Characteristics



Note: Measured with OUT2 = 156.25MHz on, 39.625MHz input.

Table 13. Jitter Performance [1][2]

Symbol	Parameter	Conditions	Minimum	Typical	Maximum	Unit
J _{CY-CY}	Cycle to Cycle Jitter	LVC MOS 3.3V ±5%, -40°C–90°C.	-	5	30	ps
		All differential outputs 3.3V ±5%, -40°C–90°C.	-	25	35	ps
J _{PK-PK}	Period Jitter	LVC MOS 3.3V ±5%, -40°C–90°C.	-	28	40	ps
		All differential outputs 3.3V ±5%, -40°C–90°C.	-	4	30	ps
J _{RMS}	RMS Phase Jitter (12kHz–20MHz)	LVC MOS 3.3V ±5%, -40°C–90°C.	-	0.3	-	ps
		All differential outputs 3.3V ±5%, -40°C–90°C.	-	0.5	-	ps

1. Measured with 25MHz crystal input.

2. Configured with OUT0 = 25MHz–LVC MOS; OUT1 = 100MHz–HCSL; OUT2 = 125MHz–LVDS; OUT3 = 156.25MHz–LVPECL.

6.1 PCI Express Jitter Performance and Specifications

Table 14. PCI Express Jitter Performance [1][2]

Parameter	Symbol	Conditions	Minimum	Typical	Maximum	Industry Limits	Unit
PCIe Jitter (Common Clock-CC)	$t_{jphPCIeG1-CC}$	PCIe Gen1 [3]	-	28.7	-	86	ps (p-p)
	$t_{jphPCIeG2-CC}$	PCIe Gen2 Low Band 10kHz < f < 1.5MHz (PLL BW of 5–16MHz or 8–16MHz, CDR = 5MHz).	-	0.27	-	3	ps (rms)
		PCIe Gen High Band 1.5MHz < f < Nyquist (50MHz) (PLL BW of 5–16MHz or 8–16MHz, CDR = 5MHz).	-	2.56	-	3.1	ps (rms)
	$t_{jphPCIeG3-CC}$	PCIe Gen3 (PLL BW of 2–4MHz or 2–5MHz, CDR = 10MHz).	-	0.8	-	1	ps (rms)
	$t_{jphPCIeG4-CC}$	PCIe Gen4 (PLL BW of 2–4MHz or 2–5MHz, CDR = 10MHz).	-	0.26	-	0.5	ps (rms)
PCIe Jitter (IR) [4][5]	$t_{jphPCIeG2-SRIS}$	PCIe Gen2 (SSC off) (PLL BW of 16MHz, CDR = 5MHz).	-	0.93	-	2	ps (rms)
	$t_{jphPCIeG3-SRIS}$	PCIe Gen3 (SSC off) (PLL BW of 2–4MHz or 2–5MHz, CDR = 10MHz).	-	0.32	-	0.7	ps (rms)

1. Confirmed by design and characterization, not 100% tested in production.
2. Based on PCIe Base Specification Rev 4.0 version 1.0. See <http://www.pcisig.com> for latest specifications.
3. Sample size of at least 100K cycles. This figure extrapolates to 108ps pk-pk at 1M cycles for a BER of 1⁻¹².
4. According to the PCIe Base Specification Rev4.0 version 1.0, the jitter transfer functions and corresponding jitter limits are not defined for the IR clock architecture. Widely accepted industry limits using widely accepted industry filters are used to populate this table. There are no accepted filters or limits for IR clock architectures at PCIe Gen1 or Gen4 data rates.
5. IR (Independent Reference) is the new name for Separate Reference Independent Spread (SRIS) and Separate Reference no Spread (SRNS) PCIe clock architectures.

7. Features and Functional Blocks

7.1 Device Startup and Power-On-Reset

The device has an internal power-up reset (POR) circuit. All V_{DD} s must be connected to desired supply voltage to trigger POR.

User can define specific default configurations through internal One-Time-Programmable (OTP) memory. Either customer or factory can program the default configuration. Please refer to [VersaClock 6E Family Register Descriptions and Programming Guide](#) for details or contact Renesas if a specific factory-programmed default configuration is required.

Device will identify which of the 2 modes to operate in by the state of OUT0_SEL_I2CB pin at POR. Both of the modes default configurations can be programmed as stated above.

1. **Software Mode (I²C):** OUT0_SEL_I2CB is low at POR.

I²C interface will be open to users for in-system programming, overriding device default configurations at any time.

2. **Hardware Select Mode:** OUT0_SEL_I2CB is high at POR.

Device has been programmed to load OTP at power-up (REG0[7] = 1). The device will load internal registers according to [Table 15](#).

Internal OTP memory can support up to 4 configurations, selectable by SEL0/SEL1 pins.

At POR, logic levels at SEL0 and SEL1 pins must be settled, resulting the selected configuration to be loaded at power up.

After the first 10ms of operation, the levels of the SELx pins can be changed, either to low or to the same level as V_{DD}/V_{DDA} . The SELx pins must be driven with a digital signal of < 300ns rise/fall time and only a single pin can be changed at a time. After a pin level change, the device must not be interrupted for at least 1ms so that the new values have time to load and take effect.

Table 15. Power-up Behavior

OUT0_SEL_I2CB at POR	SEL1	SEL0	I ² C Access	REG0:7	Config
1	0	0	No	0	0
1	0	1	No	0	1
1	1	0	No	0	2
1	1	1	No	0	3
0	X	X	Yes	1	I ² C defaults
0	X	X	Yes	0	0

7.2 Reference Clock and Selection

The device supports up to two clock inputs.

- Crystal input, can be driven by a single-ended clock.
- Clock input (CLKIN, CLKINB), a fully differential input that only accepts a reference clock. A single-ended clock can also drive it on CLKIN.

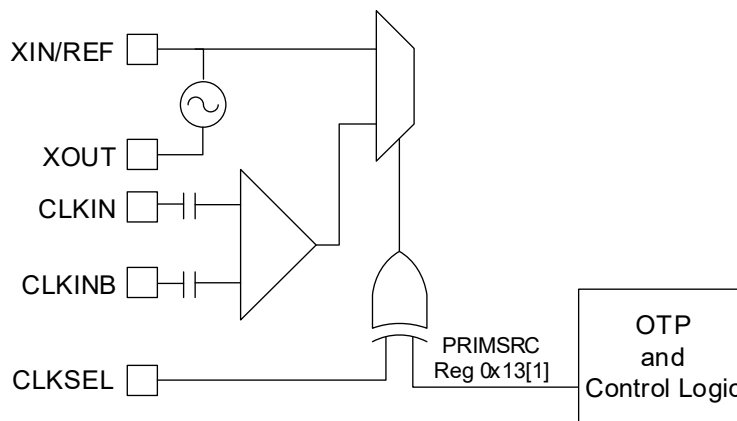

Figure 6. Clock Input Diagram, Internal Logic

7.3 Manual Switchover

The CLKSEL pin selects the input clock between either XTAL/REF or (CLKIN, CLKINB). CLKSEL polarity can be changed by I²C programming (Byte 0x13[1]) as shown in [Table 16](#).

0 = XIN/REF, XOUT (default); 1 = CLKIN, CLKINB.

Table 16. Input Clock Select

PRIMSRC (Register 0x13[1])	CLKSEL	Source
0	0	XIN/REF
0	1	CLKIN, CLKINB
1	0	CLKIN, CLKINB
1	1	XIN/REF

When SM[1:0] is "0x", the redundant inputs are in manual switchover mode. In this mode, CLKSEL pin is used to switch between the primary and secondary clock sources. The PRIMSRC bit determines the primary and secondary clock source setting. During the switchover, no glitches will occur at the output of the device, although there may be frequency and phase drift, depending on the exact phase and frequency relationship between the primary and secondary clocks.

7.4 Internal Crystal Oscillator (XIN/REF)

7.4.1 Choosing Crystals

A crystal manufacturer will calibrate its crystals to the nominal frequency with a certain load capacitance value. When the oscillator load capacitance matches the crystal load capacitance, the oscillation frequency will be accurate. When the oscillator load capacitance is lower than the crystal load capacitance, the oscillation frequency will be higher than nominal and vice versa so for an accurate oscillation frequency you need to make sure to match the oscillator load capacitance with the crystal load capacitance.

7.4.2 Tuning the Crystal Load Capacitor

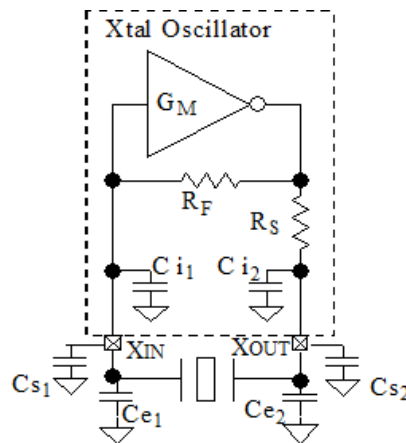

Cs1 and Cs2 are stray capacitances at each crystal pin and typical values are between 1pF and 3pF.

Ce1 and Ce2 are additional external capacitors, increasing the load capacitance reduces the oscillator gain so please consult the factory when adding Ce1 and/or Ce2 to avoid crystal startup issues. Ci1 and Ci2 are integrated programmable load capacitors, one at XIN and one at XOUT. Ci1 and Ci2.

The value of each capacitor is composed of a fixed capacitance amount plus a variable capacitance amount set with the XTAL[5:0] register.

Ci1 and Ci2 are commonly programmed to be the same value. Adjustment of the crystal tuning capacitors allows maximum flexibility to accommodate crystals from various manufacturers. The range of tuning capacitor values available are in accordance with the following table.

Ci1/Ci2 starts at 9pF with setting 000000b and can be increased up to 25pF with setting 111111b. The step per bit is 0.5pF.

Table 17. XTAL[5:0] Tuning Capacitor

Parameter	Bits	Step (pF)	Minimum (pF)	Maximum (pF)
XTAL	6	0.5	9	25

You can write the following equation for this capacitance:

$$C_i = 9\text{pF} + 0.5\text{pF} \times \text{XTAL}[5:0]$$

$$C_{XIN} = C_{i1} + C_{s1} + C_{e1}$$

$$C_{XOUT} = C_{i2} + C_{s2} + C_{e2}$$

The final load capacitance of the crystal:

$$C_L = C_{XIN} \times C_{XOUT} / (C_{XIN} + C_{XOUT})$$

It is recommended to set the same value for capacitors the same at each crystal pin, meaning:

$$C_{XIN} = C_{XOUT}$$

Example 1: The crystal load capacitance is specified as 8pF and the stray capacitance at each crystal pin is Cs = 1.5pF. Assuming equal capacitance value at XIN and XOUT, the equation is as follows:

$$8\text{pF} = (9\text{pF} + 0.5\text{pF} \times \text{XTAL}[5:0] + 1.5\text{pF}) / 2$$

So, XTAL[5:0] = 11 (decimal).

Example 2: The crystal load capacitance is specified as 12pF and the stray capacitance Cs is unknown. Footprints for external capacitors Ce are added and a worst case Cs of 5pF is used. For now we use Cs + Ce = 5pF and the right value for Ce can be determined later to make 5pF together with Cs.

$$12\text{pF} = (9\text{pF} + 0.5\text{pF} \times \text{XTAL}[5:0] + 5\text{pF}) / 2$$

So, XTAL[5:0] = 20 (decimal).

Table 18. Recommended Crystal Characteristics

Parameter	Minimum	Typical	Maximum	Unit
Mode of Oscillation	Fundamental			
Frequency	8	25	40	MHz
Equivalent Series Resistance (ESR)		10	100	Ω
Shunt Capacitance			7	pF
Load Capacitance (CL) at <= 25MHz	6	8	12	pF
Load Capacitance (CL) > 25MHz to 40MHz	6		8	pF
Maximum Crystal Drive Level			100	μW

7.5 Programmable Loop Filter

Table 19. Loop Filter

The device PLL loop bandwidth range depends on the input reference frequency (Fref).

Input Reference Frequency (MHz)	Loop Bandwidth Minimum (kHz)	Loop Bandwidth Maximum (kHz)
1	40	126
350	300	1000

7.6 Fractional Output Dividers (FOD)

The device has 4 fractional output dividers (FOD). Each of the FODs are comprised of a 12-bit integer counter, and a 24-bit fractional counter. The output divider can operate in integer divide only mode for improved performance, or utilize the fractional counters to generate a clock frequency accurate to 50ppb.

FOD has the following features:

7.6.1 Individual Spread Spectrum Modulation

The output clock frequencies can be modulated to spread energy across a broader range of frequencies, lowering system EMI.

Each divider has individual spread ability. Spread modulation independent of output frequency, a triangle wave modulation between 30kHz and 63kHz.

Spread spectrum can be applied to any output clock, any clock frequency, and any spread amount from $\pm 0.25\%$ to $\pm 2.5\%$ center-spread and -0.5% to -5% down-spread.

7.6.2 Bypass Mode

Bypass mode (divide by 1) to allow the output to behave as a buffered copy from the input or another FOD.

7.6.3 Dividers Alignment

Each output divider block has a synchronizing pulse to provide startup alignment between outputs dividers. This allows alignment of outputs for low skew performance.

When the device is at hardware select mode, outputs will be automatically aligned at POR. The same synchronization reset is also triggered when switching between configurations with the SEL0/1 pins. This ensures that the outputs remain aligned in every configuration.

When using software mode I²C to reprogram an output divider during operation, alignment can be lost. Alignment can be restored by manually triggering the reset through I²C.

The outputs are aligned on the falling edges of each output by default. Rising edge alignment can also be achieved by utilizing the programmable skew feature to delay the faster clock by 180 degrees. The programmable skew feature also allows for fine tuning of the alignment.

7.6.4 Programmable Skew

The device has the ability to skew outputs by quadrature values. The skew on each output can be adjusted from 0 to 360 degrees. Skew is adjusted in units equal to 1/32 of the VCO period. So, for 100MHz output and a 2500MHz VCO, you can select how many 12.5ps units you want added to your skew (resulting in units of 0.45 degrees). For example, 0, 0.45, 0.90, 1.35, 1.80, and so on. The granularity of the skew adjustment is always dependent on the VCO period and the output period.

7.7 Output Drivers

The device output drivers support the following features individually:

- 2.5V or 3.3V voltage level for HCSL/LVPECL operation
- 1.8V, 2.5V or 3.3V voltage levels for CMOS/LVDS operation
- CMOS supports 4 operating modes:
 - CMOSD: OUTx and OUTxB 180 degrees out of phase
 - CMOSX2: OUTx and OUTxB phase-aligned
 - CMOS1: only OUTx pin is on
 - CMOS2: only OUTxB pin is on

When a given output is configured to at CMOSD or CMOSX2, then all previously described configuration and control apply equally to both pins.

- Independent output enable/disabled by register bits. When disabled, an output can be either in a logic 1 state or Hi-Z.

The following options are used to disable outputs:

1. Output turned off by I²C.
2. Output turned off by SD/OE pin.
3. Output unused, which means is turned off regardless of OE pin status.

7.8 SD/OE Pin Function

SD/OE pin can be programmed as following functions:

1. OE output enable (low active).
2. OE output enable (high active).
 - a. *Note:* In this mode, toggling the OE input from low level to high level is mandatory to activate outputs. This should occur after the device has started up and the PLL has reached lock status. Please refer to [VersaClock 6E Family Register Descriptions and Programming Guide](#), chapter “Shutdown Function”, for details.
3. Global shutdown (low active).
4. Global shutdown (high active).

Output behavior when disabled is also programmable. User will have the option to choose output driver behavior when it's off:

1. OUTx pin high, OUTxB pin low. (Controlled by SD/OE pin).
2. OUTx/OUTxB Hi-Z (Controlled by SD/OE pin).
3. OUTx pin high, OUTxB pin low. (Configured through I²C).
4. OUTx/OUTxB Hi-Z (Configured by I²C).

The user has the option to disable the output with either I²C or SD/OE pin. Refer to [VersaClock 6E Family Register Descriptions and Programming Guide](#) for details.

7.9 I²C Operation

The device acts as a slave device on the I²C bus using one of the two I²C addresses (0xD0 or 0xD4) to allow multiple devices to be used in the system. The interface accepts byte-oriented block write and block read operations.

Address bytes (2 bytes) specify the register address of the byte position of the first register to write or read.

Data bytes (registers) are accessed in sequential order from the lowest to the highest byte (most significant bit first).

Read and write block transfers can be stopped after any complete byte transfer. During a write operation, data will not be moved into the registers until the STOP bit is received, at which point, all data received in the block write will be written simultaneously.

For full electrical I²C compliance, use external pull-up resistors for SDATA and SCLK.

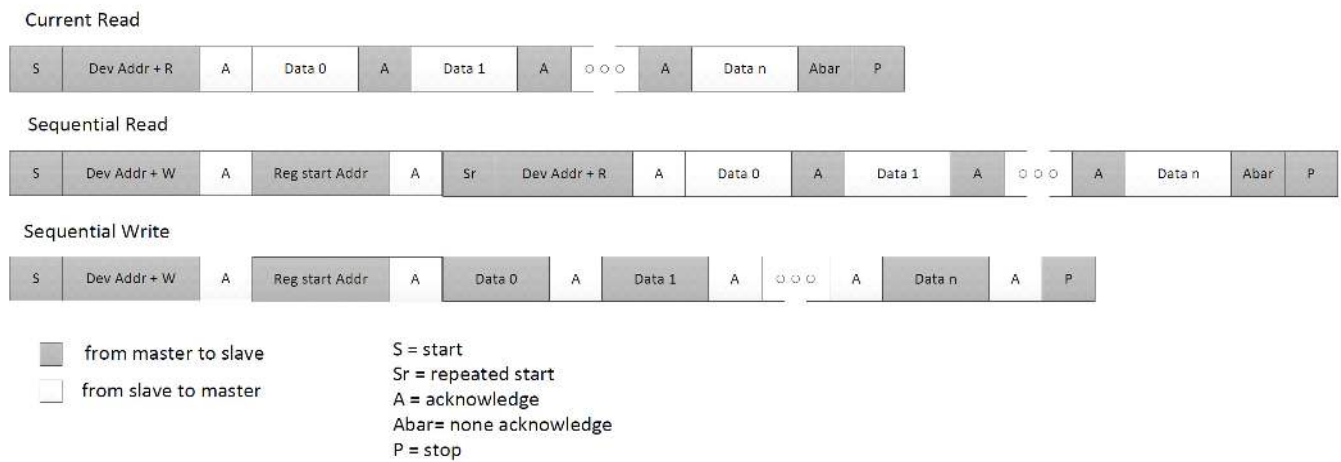

Figure 7. I²C R/W Sequence

8. Typical Application Circuit

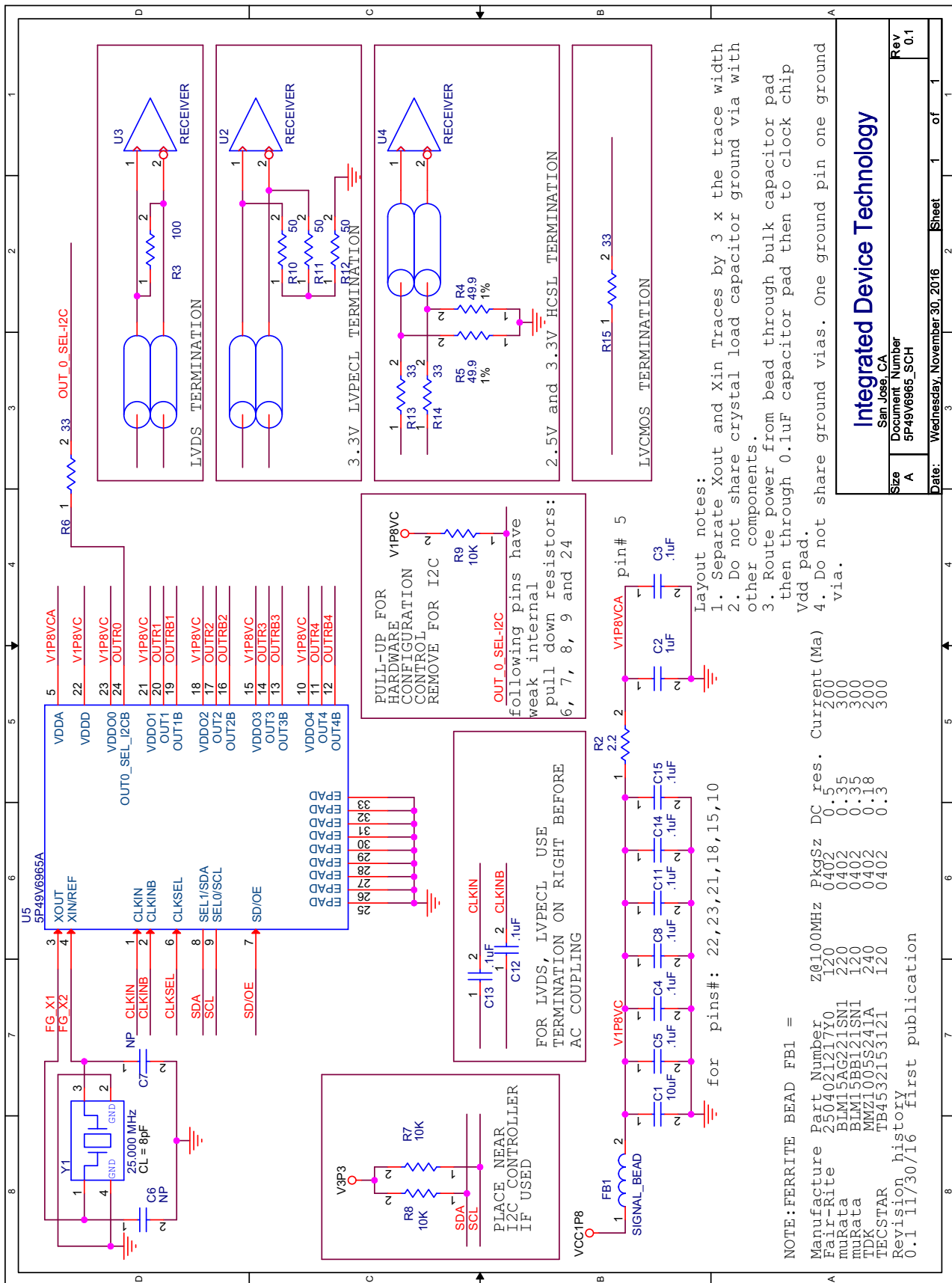

Figure 8. Application Circuit Example

8.1 Input – Driving the XIN/REF or CLKIN

8.1.1 Driving XIN/REF with a CMOS Driver

In some cases, it is encouraged to have XIN/REF driven by a clock input for reasons like better SNR, multiple input select with device CLKIN, etc. The XIN/REF pin requires an input amplitude between 500mV and 1.2V. The clock slew rate should be at least 0.2V/ns ($\geq 0.2V/ns$).

The XIN/REF input can be overdriven by an LVCMOS driver or by one side of a differential driver through an AC coupling capacitor. The XOUT pin can be left floating.

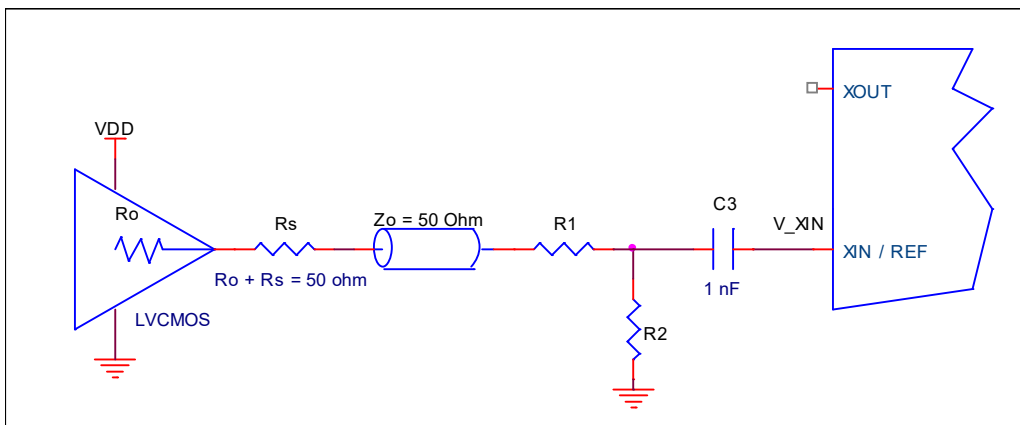

Figure 9. Overdriving XIN with a CMOS Driver

Table 20. Nominal Voltage Divider Values for Overdriving XIN with Single-ended Driver

LVCMOS Diver V_{DD}	$R_o + R_s$	R_1	R_2	$V_{XIN} (peak)$	$R_o + R_s + R_1 + R_2$
3.3	50.0	130	75	0.97	255
2.5	50.0	100	100	1.00	250
1.8	50.0	62	130	0.97	242

8.1.2 Driving XIN with an LVPECL Driver

Figure 10 shows an example of the interface diagram for a +3.3V LVPECL driver. This is a standard LVPECL termination with one side of the driver feeding the XIN/REF input. It is recommended that all components in the schematics be placed in the layout; though some components might not be used, they can be utilized for debugging purposes. The datasheet specifications are characterized and guaranteed by using a quartz crystal as the input. If the driver is 2.5V LVPECL, the only change necessary is to use the appropriate value of R3.

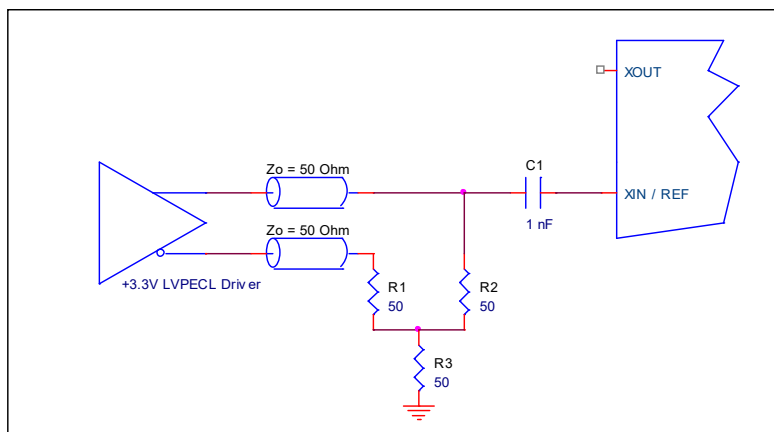

Figure 10. Overdriving XIN with an LVPECL Driver

8.1.3 Wiring the CLKIN Pin to Accept Single-ended Inputs

CLKIN cannot take a signal larger than 1.2V pk-pk due to the 1.2V regulated input inside. However, it is internally AC coupled so it is able to accept both LVDS and LVPECL input signals.

Occasionally, it is desired to have CLKIN to take CMOS levels. Below is an example showing how this can be achieved.

This configuration has three properties:

1. Total output impedance of R_o and R_s matches the 50Ω transmission line impedance.
2. V_{rx} voltage is generated at the CLKIN which maintains the LVCMOS driver voltage level across the transmission line for best S/N.
3. R_1 – R_2 voltage divider values ensure that V_{rx} p-p at CLKIN is less than the maximum value of 1.2V.

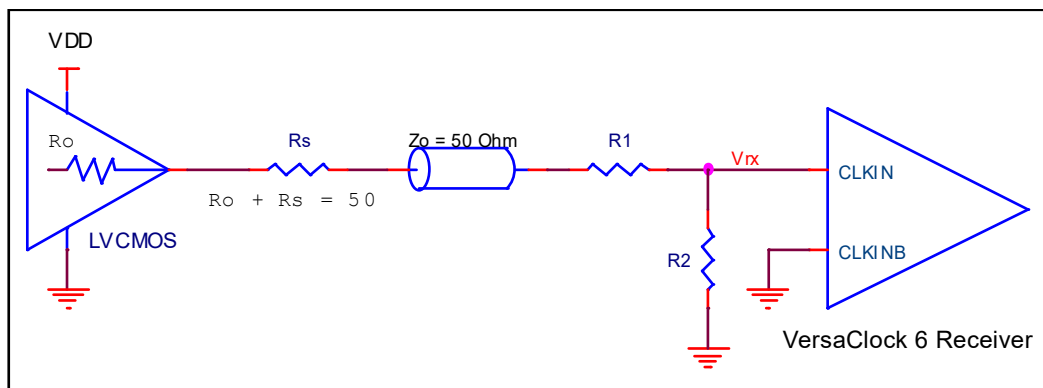

Figure 11. Recommended Schematic for Driving CLKIN with LVCMOS Driver

Table 21 shows resistor values that ensure the maximum drive level for the CLKIN port is not exceeded for all combinations of 5% tolerance on the driver V_{DD} , V_{DDO0} and 5% resistor tolerances. The values of the resistors can be adjusted to reduce the loading for slower and weaker LVCMOS driver by increasing the impedance of the R_1 – R_2 divider. To better assist this assessment, the total load ($R_o + R_s + R_1 + R_2$) on the driver is included in the table.

Table 21. Nominal Voltage Divider Values for Overdriving CLKIN with Single-ended Driver

LVCMOS Diver V_{DD}	$R_o + R_s$	R_1	R_2	V_{rx} (peak)	$R_o + R_s + R_1 + R_2$
3.3	50.0	130	75	0.97	255
2.5	50.0	100	100	1.00	250
1.8	50.0	62	130	0.97	242

8.1.4 Driving CLKIN with Differential Clock

CLKIN/CLKINB will accept DC coupled HCSL/LVPECL/LVDS signals.

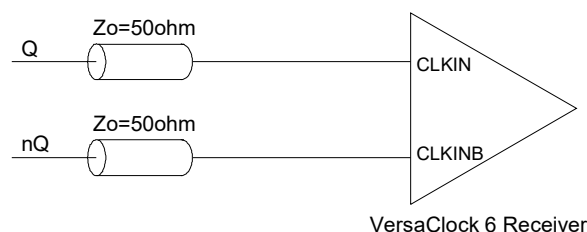

Figure 12. CLKIN, CLKINB Input Driven by an HCSL Driver

8.2 Output – Single-ended or Differential Clock Terminations

8.2.1 LVDS Termination

For a general LVDS interface, the recommended value for the termination impedance (Z_T) is between 90Ω and 132Ω . The actual value should be selected to match the differential impedance (Z_0) of your transmission line. A typical point-to-point LVDS design uses a 100Ω parallel resistor at the receiver and a 100Ω differential transmission-line environment. In order to avoid any transmission-line reflection issues, the components should be surface mounted and must be placed as close to the receiver as possible. The standard termination schematic as shown in figure “Standard Termination” or the termination of figure “Optional Termination” can be used, which uses a center tap capacitance to help filter common mode noise. The capacitor value should be approximately 50pF . In addition, since these outputs are LVDS compatible, the input receiver's amplitude and common-mode input range should be verified for compatibility with the Renesas LVDS output. If using a non-standard termination, it is recommended to contact Renesas and confirm that the termination will function as intended. For example, the LVDS outputs cannot be AC coupled by placing capacitors between the LVDS outputs and the 100Ω shunt load. If AC coupling is required, the coupling caps must be placed between the 100Ω shunt termination and the receiver. In this manner, the termination of the LVDS output remains DC coupled.

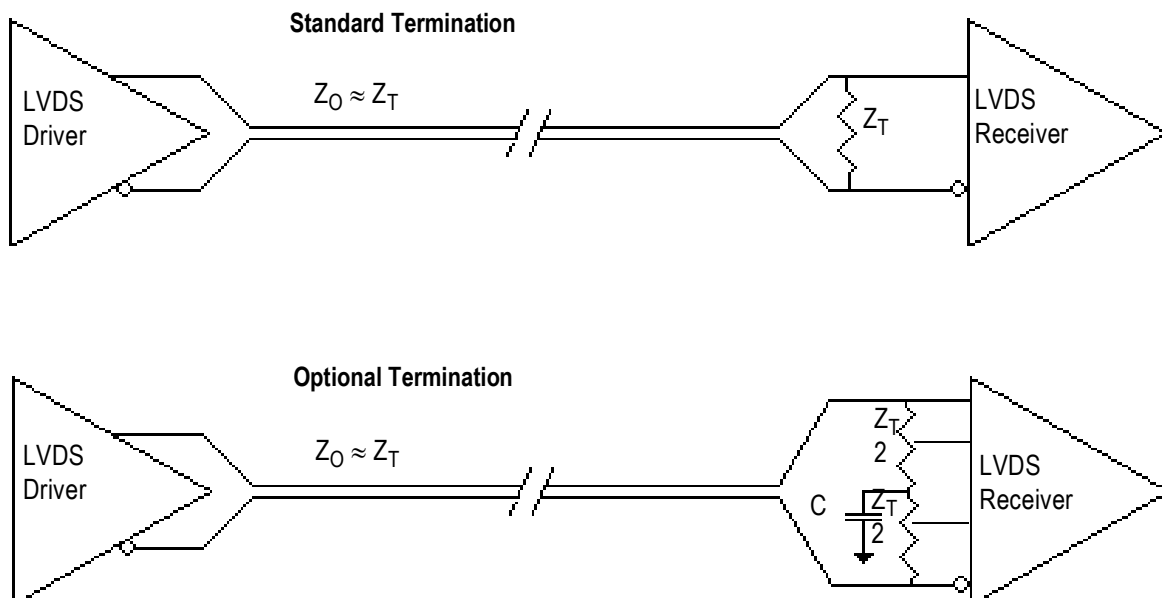

Figure 13. Standard and Optional Terminations

8.2.2 LVPECL Termination

The clock layout topology shown below is a typical termination for LVPECL outputs.

The differential outputs generate ECL/LVPECL compatible outputs. Therefore, terminating resistors (DC current path to ground) or current sources must be used for functionality. These outputs are designed to drive 50Ω transmission lines. Matched impedance techniques should be used to maximize operating frequency and minimize signal distortion.

For $V_{DDO} = 2.5\text{V}$, the $V_{DDO} - 2\text{V}$ is very close to ground level. The R_3 in 2.5V LVPECL output termination can be eliminated and the termination is shown in [Figure 16](#), 2.5V LVPECL Output Termination.

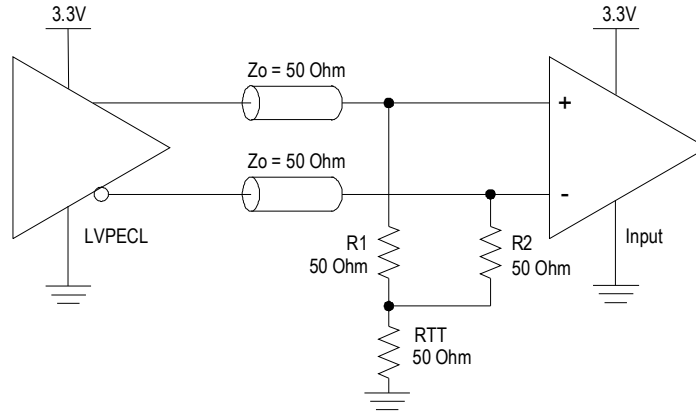

Figure 14. 3.3V LVPECL Output Termination (1)

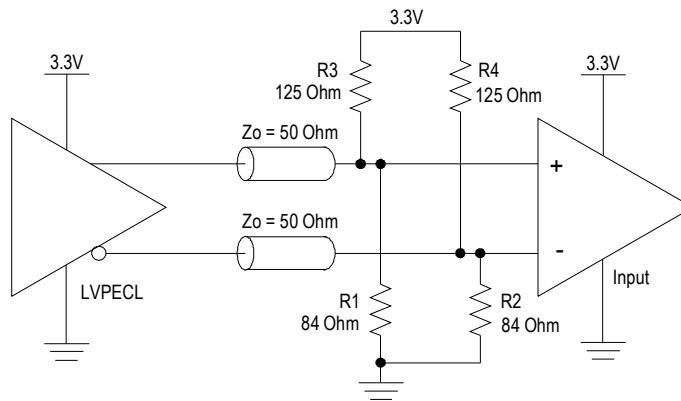

Figure 15. 3.3V LVPECL Output Termination (2)

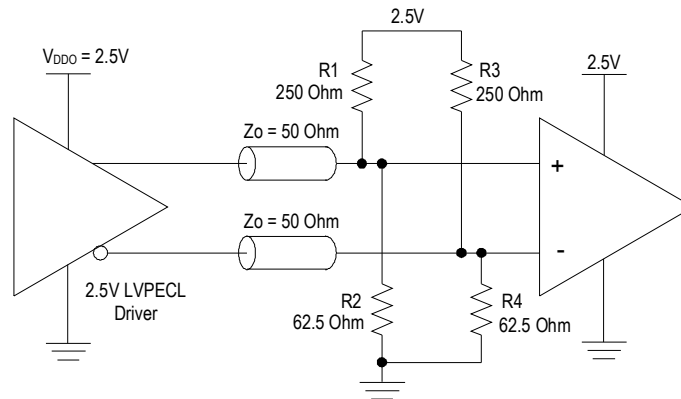

Figure 16. 2.5V LVPECL Output Termination

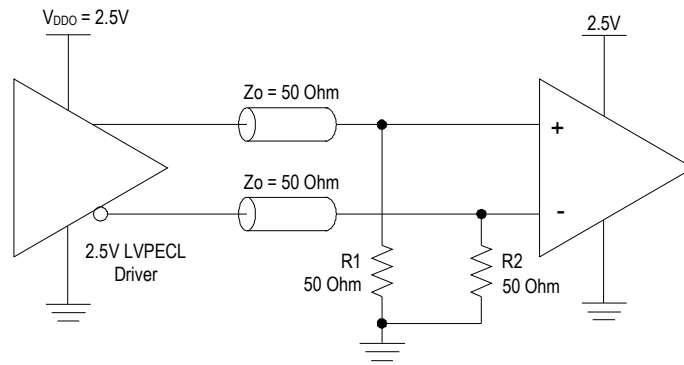

Figure 17. 2.5V LVPECL Driver Termination (1)

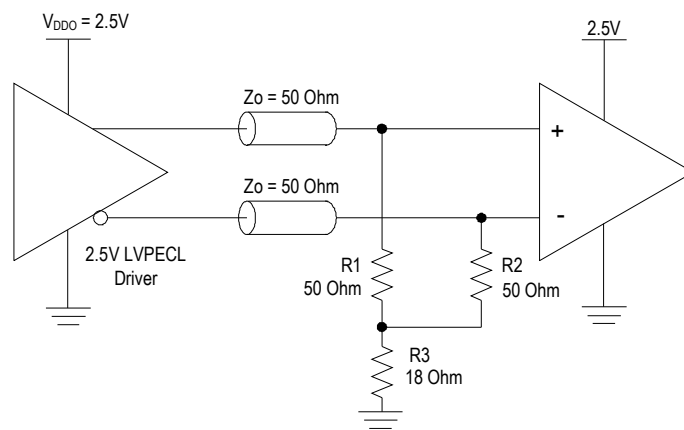

Figure 18. 2.5V LVPECL Driver Termination (2)

8.2.3 HCSL Termination

HCSL termination scheme applies to both 3.3V and 2.5V V_{DDO} .

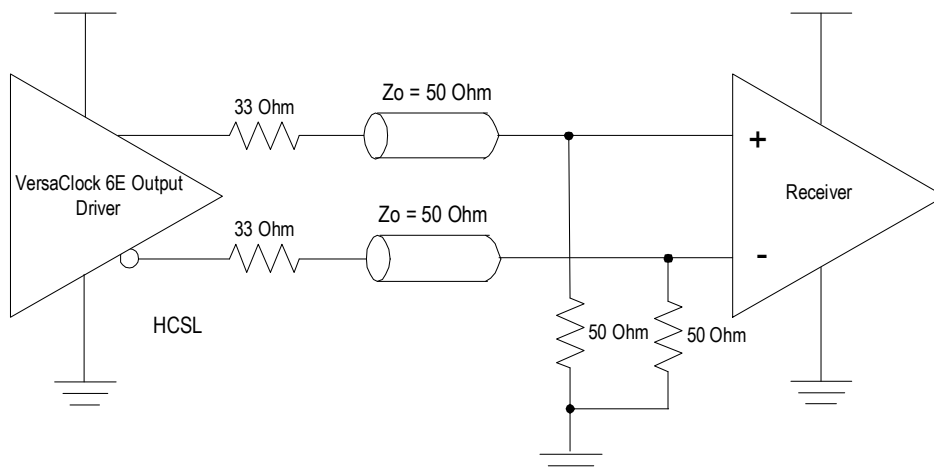

Figure 19. HCSL Receiver Terminated

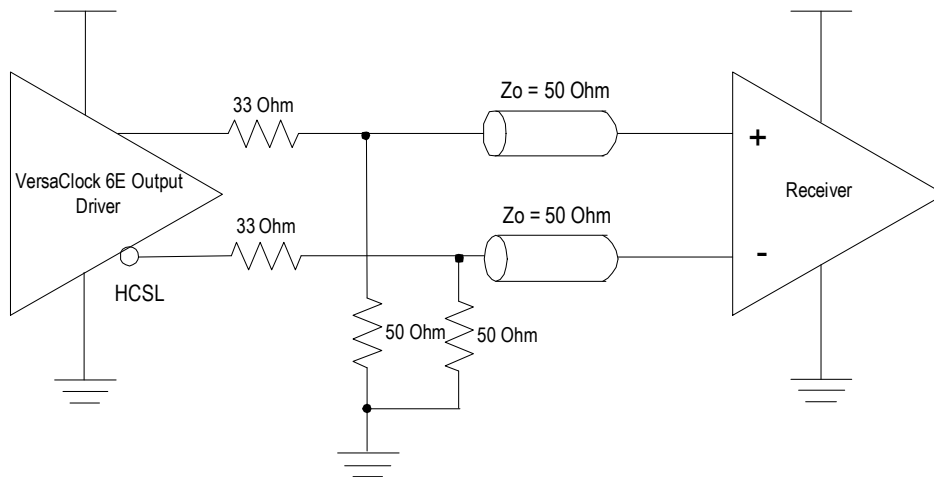

Figure 20. HCSL Source Terminated

8.2.4 LVCMOS Termination

Each output pair can be configured as a standalone CMOS or dual-CMOS output driver. Example of CMOSD driver termination is shown below.

CMOS1 – Single CMOS active on OUTx pin.

CMOS2 – Single CMOS active on OUTxB pin.

CMOSD – Dual CMOS outputs active on both OUTx and OUTxB pins, 180 degrees out of phase.

CMOSX2 – Dual CMOS outputs active on both OUTx and OUTxB pins, in-phase.

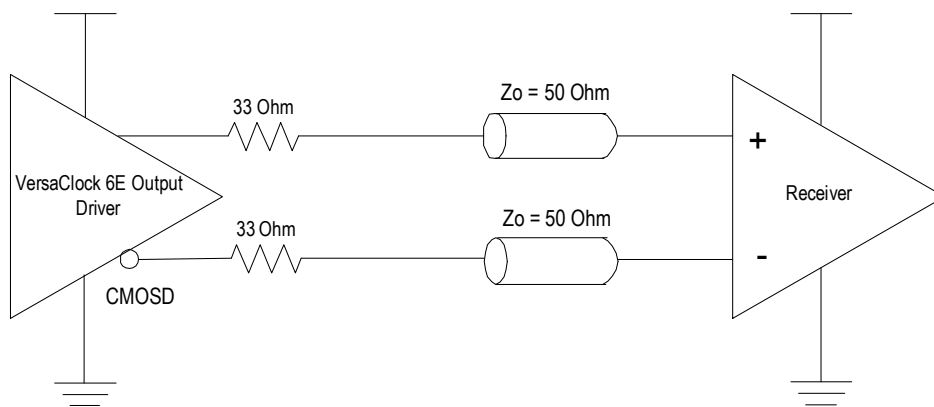
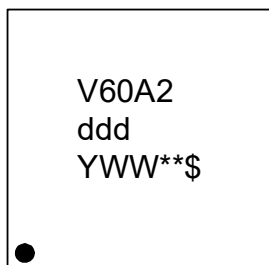

Figure 21. LVCMOS Termination

9. Package Outline Drawings

The package outline drawings are located at the end of this document and are accessible from the Renesas website (see [Ordering Information](#) for POD links). The package information is the most current data available and is subject to change without revision of this document.

10. Marking Diagram



- Line 1: truncated part number.
- Line 2: “ddd” denotes dash code.
- Line 3:
 - “YWW” is the last digit of the year and week that the part was assembled.
 - “**” denotes sequential lot number.
 - “\$” denotes mark code.

11. Ordering Information

Part Number	Package Description	Carrier Type	Temperature Range
5P49V60AdddNLG2	24-VFQFPN, 4 × 4 mm, 0.5mm pitch, wettable flank	Tray	-40 to +105°C
5P49V60AdddNLG28		Reel	

12. Revision History

Revision	Date	Description
1.10	Dec 16, 2022	<ul style="list-style-type: none"> ▪ Changed first line of Description on page 1 to “The 5P49V60 is a commercial, programmable clock generator supporting automotive applications” from “The 5P49V60 is a programmable clock generator intended for automotive applications.” ▪ Changed last bullet on front page to “-40°C to +105°C (Grade 2 equivalent) operating temperature” from “-40° to +105°C (Grade 2) temperature operation”.
-	Mar 16, 2021	Updated the figure Overdriving XIN with an LVPECL Driver
-	Jan 26, 2021	Updated links to all VersaClock 6E Family Register Descriptions and Programming Guide references. Added note and document link in section SD/OE Pin Function under item 2.
-	Dec 10, 2020	Updated text for clock slew rate values in the section “Driving XIN/REF with a CMOS Driver”.
-	Sep 4, 2020	Updated pin 4 description. Updated VIH minimum value. Updated the section Driving XIN/REF with a CMOS Driver .
-	Aug 20, 2020	Updated the slew rate terminology in section Driving XIN/REF with a CMOS Driver .
-	Oct 14, 2019	Added PCIe Gen4 to Typical Applications.
-	Mar 8, 2019	Updated package outline drawings.
-	Feb 22, 2019	Updated marking diagram.
-	Jul 12, 2018	Initial release.

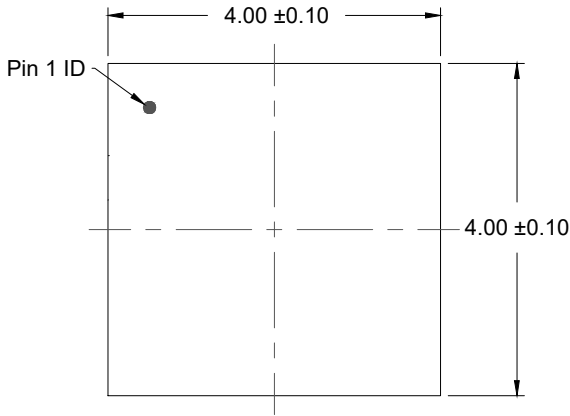

TOP VIEW

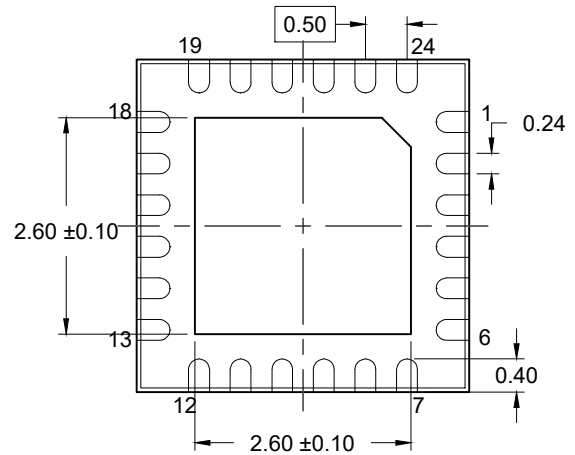

BOTTOM VIEW

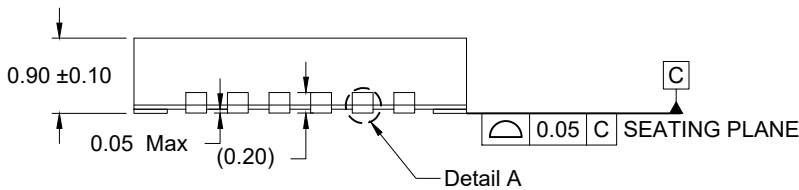

SIDE VIEW

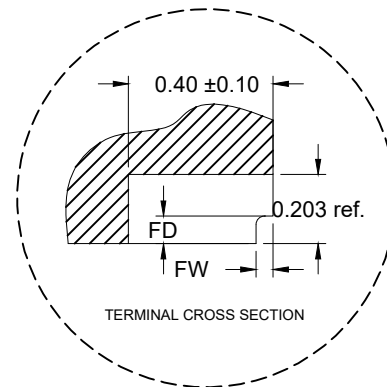

TERMINAL CROSS SECTION

DETAIL A

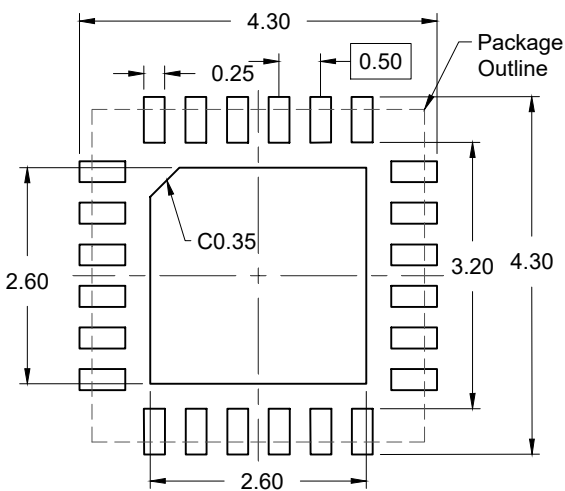

RECOMMENDED LAND PATTERN
(PCB Top View, NSMD Design)

Table 1: Dimensions of wettable flank (DETAIL A)

Symbol	Unit (mm)	
	MIN	MAX
FD	0.100	-
FW	0.001	0.075

NOTES:

1. JEDEC compatible.
2. All dimensions are in mm and angles are in degrees.
3. Use ± 0.05 mm for the non-toleranced dimensions.
4. Numbers in () are for references only.
5. Wettable flank (step cut).

Notice

1. Descriptions of circuits, software and other related information in this document are provided only to illustrate the operation of semiconductor products and application examples. You are fully responsible for the incorporation or any other use of the circuits, software, and information in the design of your product or system. Renesas Electronics disclaims any and all liability for any losses and damages incurred by you or third parties arising from the use of these circuits, software, or information.
2. Renesas Electronics hereby expressly disclaims any warranties against and liability for infringement or any other claims involving patents, copyrights, or other intellectual property rights of third parties, by or arising from the use of Renesas Electronics products or technical information described in this document, including but not limited to, the product data, drawings, charts, programs, algorithms, and application examples.
3. No license, express, implied or otherwise, is granted hereby under any patents, copyrights or other intellectual property rights of Renesas Electronics or others.
4. You shall be responsible for determining what licenses are required from any third parties, and obtaining such licenses for the lawful import, export, manufacture, sales, utilization, distribution or other disposal of any products incorporating Renesas Electronics products, if required.
5. You shall not alter, modify, copy, or reverse engineer any Renesas Electronics product, whether in whole or in part. Renesas Electronics disclaims any and all liability for any losses or damages incurred by you or third parties arising from such alteration, modification, copying or reverse engineering.
6. Renesas Electronics products are classified according to the following two quality grades: "Standard" and "High Quality". The intended applications for each Renesas Electronics product depends on the product's quality grade, as indicated below.
 - "Standard": Computers; office equipment; communications equipment; test and measurement equipment; audio and visual equipment; home electronic appliances; machine tools; personal electronic equipment; industrial robots; etc.
 - "High Quality": Transportation equipment (automobiles, trains, ships, etc.); traffic control (traffic lights); large-scale communication equipment; key financial terminal systems; safety control equipment; etc.Unless expressly designated as a high reliability product or a product for harsh environments in a Renesas Electronics data sheet or other Renesas Electronics document, Renesas Electronics products are not intended or authorized for use in products or systems that may pose a direct threat to human life or bodily injury (artificial life support devices or systems; surgical implantations; etc.), or may cause serious property damage (space system; undersea repeaters; nuclear power control systems; aircraft control systems; key plant systems; military equipment; etc.). Renesas Electronics disclaims any and all liability for any damages or losses incurred by you or any third parties arising from the use of any Renesas Electronics product that is inconsistent with any Renesas Electronics data sheet, user's manual or other Renesas Electronics document.
7. No semiconductor product is absolutely secure. Notwithstanding any security measures or features that may be implemented in Renesas Electronics hardware or software products, Renesas Electronics shall have absolutely no liability arising out of any vulnerability or security breach, including but not limited to any unauthorized access to or use of a Renesas Electronics product or a system that uses a Renesas Electronics product. RENESAS ELECTRONICS DOES NOT WARRANT OR GUARANTEE THAT RENESAS ELECTRONICS PRODUCTS, OR ANY SYSTEMS CREATED USING RENESAS ELECTRONICS PRODUCTS WILL BE INVULNERABLE OR FREE FROM CORRUPTION, ATTACK, VIRUSES, INTERFERENCE, HACKING, DATA LOSS OR THEFT, OR OTHER SECURITY INTRUSION ("Vulnerability Issues"). RENESAS ELECTRONICS DISCLAIMS ANY AND ALL RESPONSIBILITY OR LIABILITY ARISING FROM OR RELATED TO ANY VULNERABILITY ISSUES. FURTHERMORE, TO THE EXTENT PERMITTED BY APPLICABLE LAW, RENESAS ELECTRONICS DISCLAIMS ANY AND ALL WARRANTIES, EXPRESS OR IMPLIED, WITH RESPECT TO THIS DOCUMENT AND ANY RELATED OR ACCOMPANYING SOFTWARE OR HARDWARE, INCLUDING BUT NOT LIMITED TO THE IMPLIED WARRANTIES OF MERCHANTABILITY, OR FITNESS FOR A PARTICULAR PURPOSE.
8. When using Renesas Electronics products, refer to the latest product information (data sheets, user's manuals, application notes, "General Notes for Handling and Using Semiconductor Devices" in the reliability handbook, etc.), and ensure that usage conditions are within the ranges specified by Renesas Electronics with respect to maximum ratings, operating power supply voltage range, heat dissipation characteristics, installation, etc. Renesas Electronics disclaims any and all liability for any malfunctions, failure or accident arising out of the use of Renesas Electronics products outside of such specified ranges.
9. Although Renesas Electronics endeavors to improve the quality and reliability of Renesas Electronics products, semiconductor products have specific characteristics, such as the occurrence of failure at a certain rate and malfunctions under certain use conditions. Unless designated as a high reliability product or a product for harsh environments in a Renesas Electronics data sheet or other Renesas Electronics document, Renesas Electronics products are not subject to radiation resistance design. You are responsible for implementing safety measures to guard against the possibility of bodily injury, injury or damage caused by fire, and/or danger to the public in the event of a failure or malfunction of Renesas Electronics products, such as safety design for hardware and software, including but not limited to redundancy, fire control and malfunction prevention, appropriate treatment for aging degradation or any other appropriate measures. Because the evaluation of microcomputer software alone is very difficult and impractical, you are responsible for evaluating the safety of the final products or systems manufactured by you.
10. Please contact a Renesas Electronics sales office for details as to environmental matters such as the environmental compatibility of each Renesas Electronics product. You are responsible for carefully and sufficiently investigating applicable laws and regulations that regulate the inclusion or use of controlled substances, including without limitation, the EU RoHS Directive, and using Renesas Electronics products in compliance with all these applicable laws and regulations. Renesas Electronics disclaims any and all liability for damages or losses occurring as a result of your noncompliance with applicable laws and regulations.
11. Renesas Electronics products and technologies shall not be used for or incorporated into any products or systems whose manufacture, use, or sale is prohibited under any applicable domestic or foreign laws or regulations. You shall comply with any applicable export control laws and regulations promulgated and administered by the governments of any countries asserting jurisdiction over the parties or transactions.
12. It is the responsibility of the buyer or distributor of Renesas Electronics products, or any other party who distributes, disposes of, or otherwise sells or transfers the product to a third party, to notify such third party in advance of the contents and conditions set forth in this document.
13. This document shall not be reprinted, reproduced or duplicated in any form, in whole or in part, without prior written consent of Renesas Electronics.
14. Please contact a Renesas Electronics sales office if you have any questions regarding the information contained in this document or Renesas Electronics products.

(Note1) "Renesas Electronics" as used in this document means Renesas Electronics Corporation and also includes its directly or indirectly controlled subsidiaries.

(Note2) "Renesas Electronics product(s)" means any product developed or manufactured by or for Renesas Electronics.

(Rev.5.0-1 October 2020)

Corporate Headquarters

TOYOSU FORESIA, 3-2-24 Toyosu,
Koto-ku, Tokyo 135-0061, Japan
www.renesas.com

Trademarks

Renesas and the Renesas logo are trademarks of Renesas Electronics Corporation. All trademarks and registered trademarks are the property of their respective owners.

Contact Information

For further information on a product, technology, the most up-to-date version of a document, or your nearest sales office, please visit:
www.renesas.com/contact/