



Since 1959

Product Information Sheet

H16 12V 19W STD

No.: H16

2019. 08. 06 NEW

2017. 06. 16 OLD

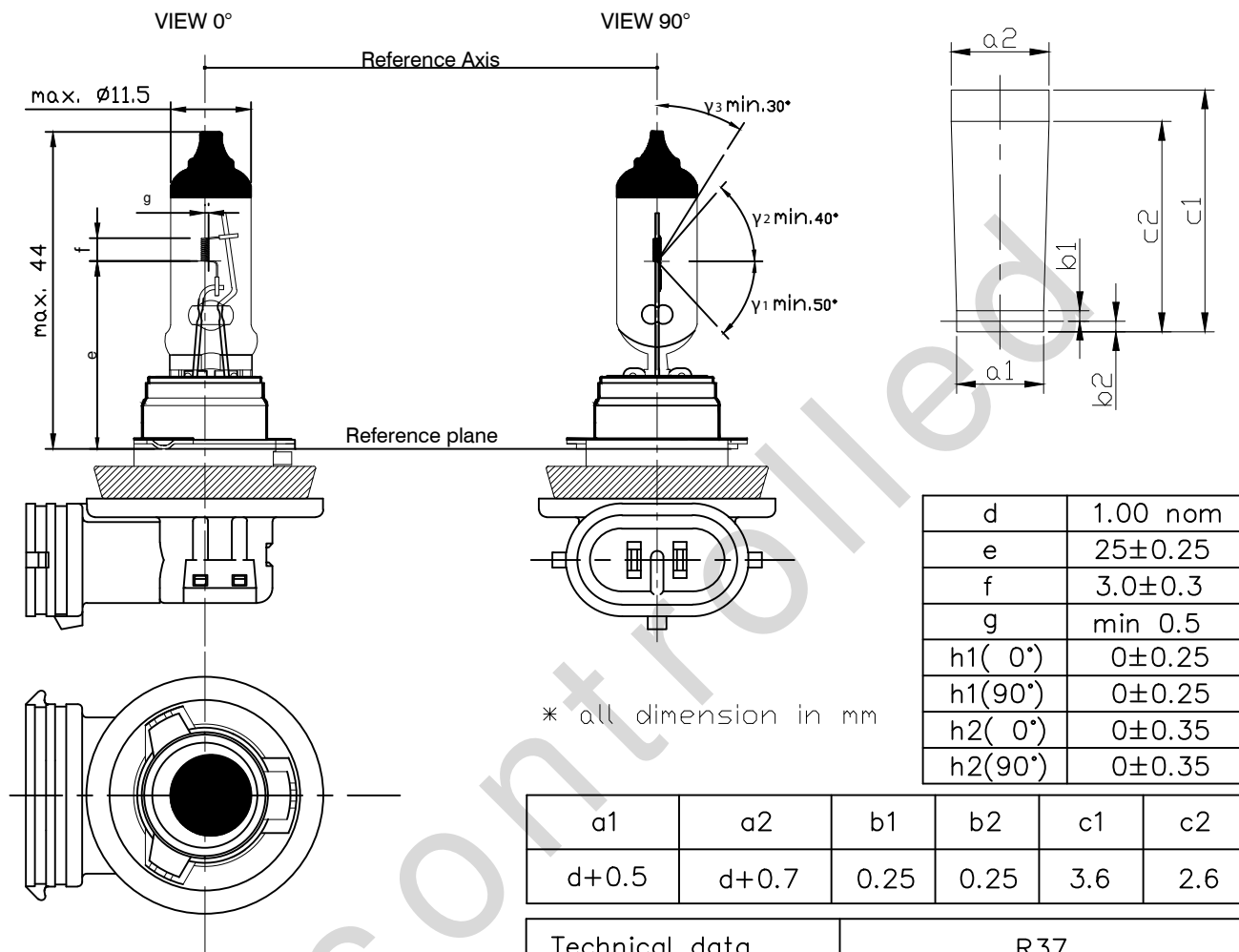

Halogen bulb
H16 12V 19W
Cap: ¹⁾ PGJ19-3
Type: STD
ECE R37 (E1) 2YV
FMVSS108 None
Bulb: UV-cut Quartz glass

a1	a2	b1	b2	c1	c2
d+0.5	d+0.7	0.25	0.25	3.6	2.6

Technical data	R37
Test voltage	13.2V
Power	26W max.
Luminous flux	500lm +10%/-15%
Lumen maintenance after 450hr	85 % min
Rated life:	^{4) 5)} at 13.2V Tc: 1000 hr B50: 900 hr B3: 500 hr
Maximum operating temperature:	1:bulb 800°C max 2:pinch 400°C max
Vibration resistance acc. to IEC 60810 Annex B; table B.2	> 20h

1) According to IEC 60061-1 sheet 7004-110-2
2) According to SAE J 1383 Annex 5.20
3) Switching cycle according to SAE J 1383 5.20.2
4) According to IEC 60810 Annex A
5) Switching cycle according to IEC 60810 Annex A;4.1.1
6) Switching cycle according to IEC 60810 Annex A;4.1.2
7) Switching cycle according to IEC 60810 Annex A;4.2