

THIS DRAWING IS UNPUBLISHED. RELEASED FOR PUBLICATION
 © COPYRIGHT - By - ALL RIGHTS RESERVED.

LOC	DIST	REVISIONS					
		P	LTR	DESCRIPTION	DATE	DWN	APVD
AF	50	M1		REVISED PER ECR-11-025318	19DEC11	KH	GJ

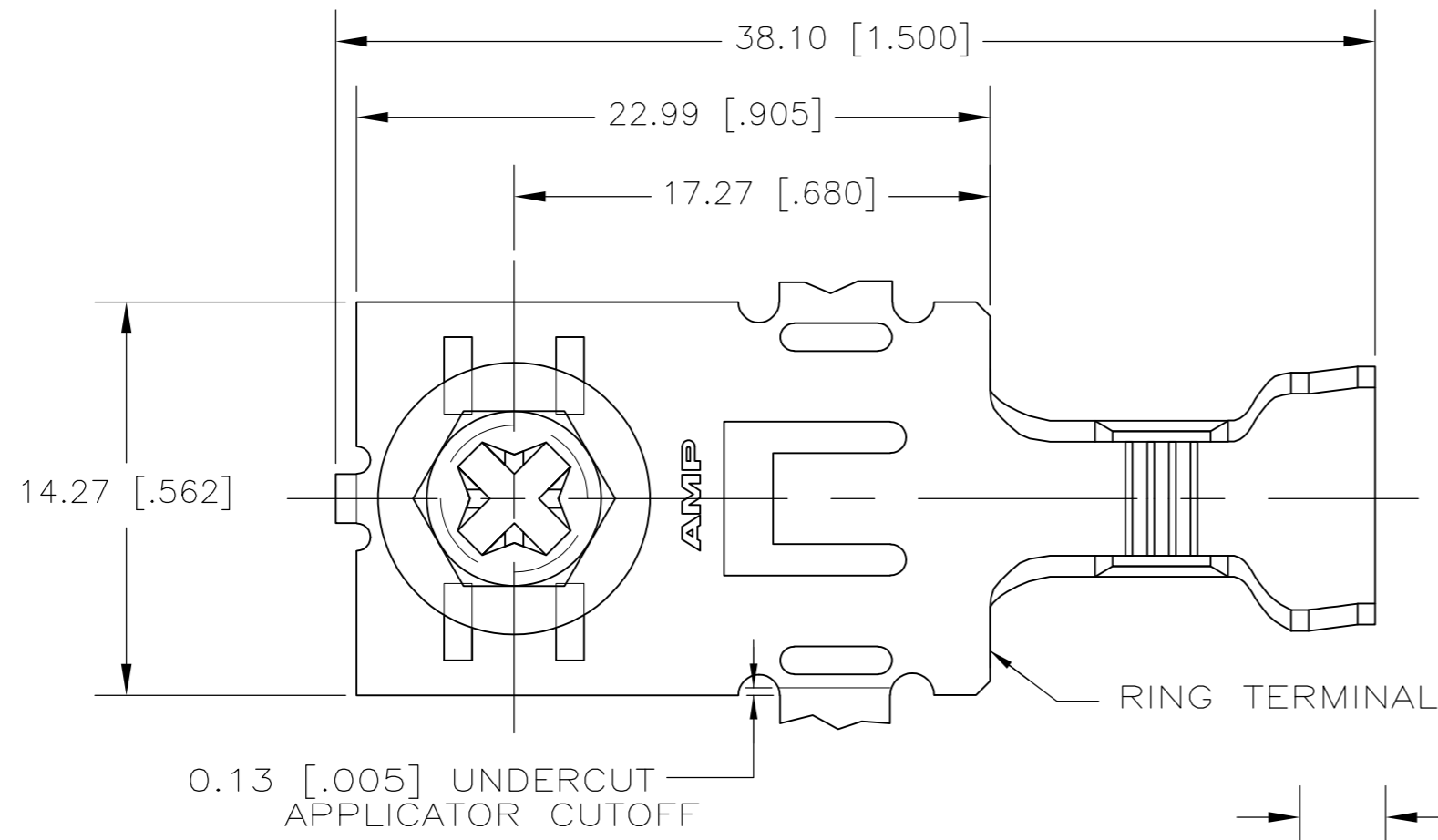

- 1 CONTINUOUS STRIP ON REELS
- 2 VERTICAL BURRS NOT TO EXCEED 0.13 [.005] ALONG THIS EDGE
- 3 BACK OUT TORQUE OF SCREW TO BE A MIN OF 5 IN LBS AND A MAX OF 25 IN LBS
- 4 WIRE SIZE #16-#10 OR TWO #12'S
- 5 INSULATION RANGE IS 5.59-7.87 [.220-.310] DIA OR TWO AT 4.32 [.170] DIA.

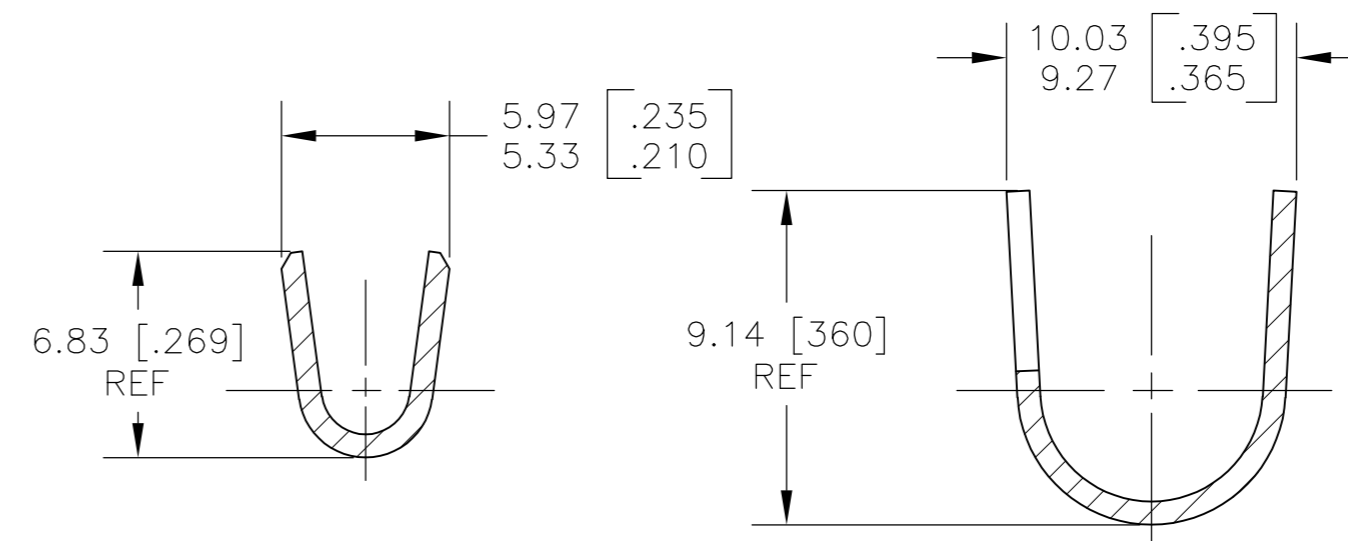
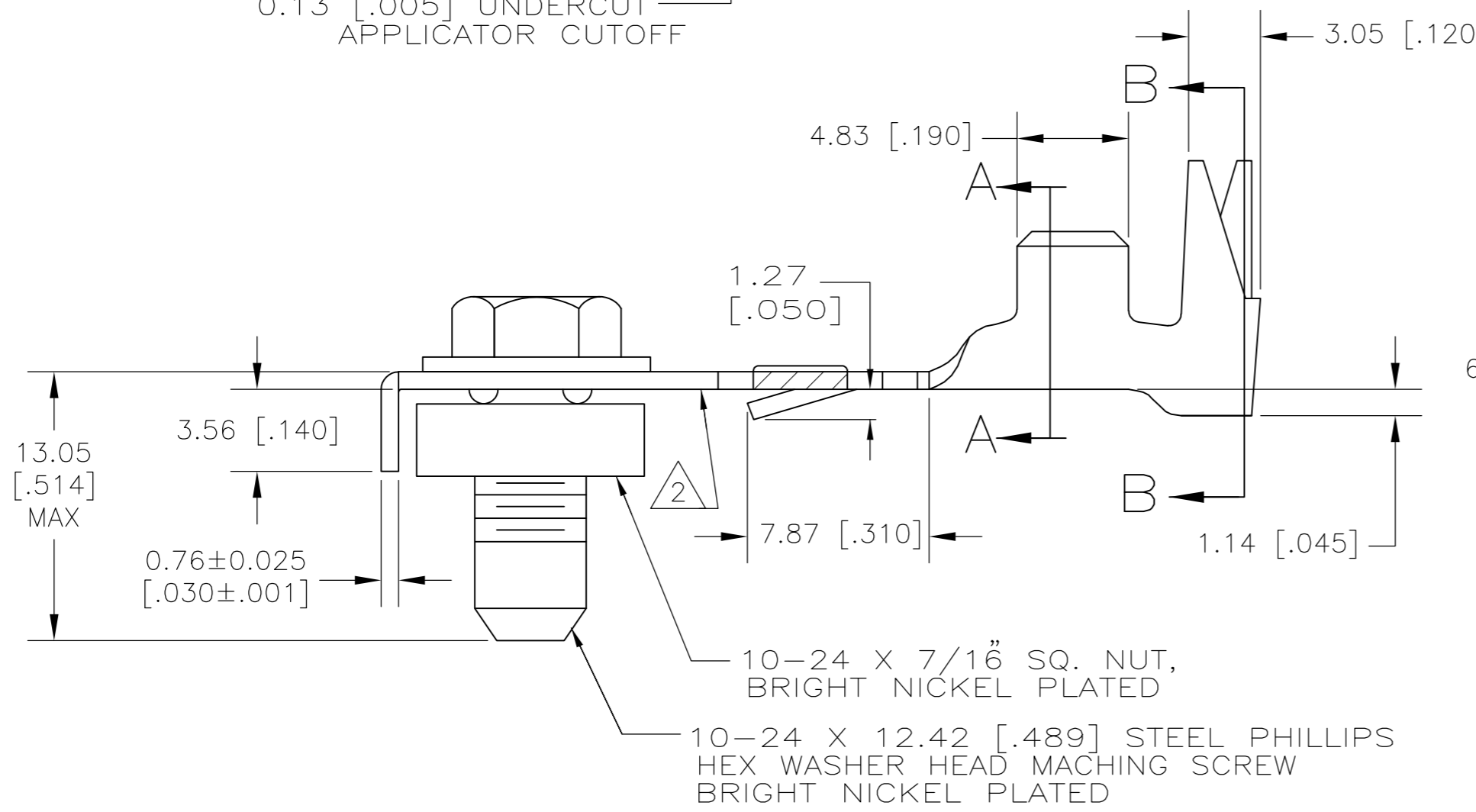

F OR O	8.89 [.350]	6.35 [.250]	F	4.57 [.180]	3.45 [.136]	2/12 ^S
					3.22 [.127]	10
					2.87 [.113]	12
					2.64 [.104]	14
					2.51 [.099]	16
TYPE	WIDTH	STRIP LENGTH	TYPE	WIDTH	±0.05 ±[.002] HEIGHT	WIRE
INSUL BARREL CRIMP		±0.38 [.015]	WIRE BARREL CRIMP			

520936-1
PART NUMBER

THIS DRAWING IS A CONTROLLED DOCUMENT.		DWN M.S. FEHER 26OCT2007	TE TE Connectivity	
DIMENSIONS: INCHES		CHK D.F. DECKER 26OCT2007		
TOLERANCES UNLESS OTHERWISE SPECIFIED:		APVD D.F. DECKER 26OCT2007	NAME	
0 PLC ± -		PRODUCT SPEC	SUB-ASSEMBLY, POWER RING	
1 PLC ± -		APPLICATION SPEC	-	
2 PLC ± 0.38 [.015]		108-1191	SIZE	CAGE CODE
3 PLC ± -		114-2087	A2	00779
4 PLC ± -		WEIGHT	DRAWING NO	RESTRICTED TO
ANGLES ± -		CUSTOMER DRAWING	C=520936	-
MATERIAL #2 HARD BRASS RING TERMINAL	FINISH NO FINISH RING TERMINAL	SCALE 4:1	SHEET 1 of 1	REV M1