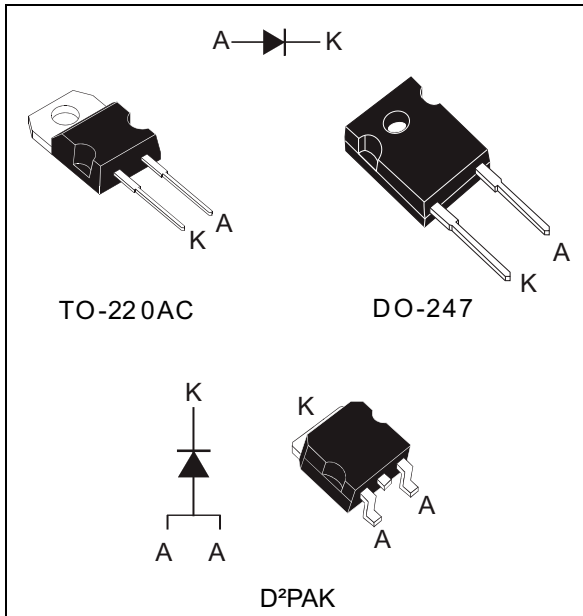

Ultrafast recovery diode

Datasheet - production data

Description

The compromise-free, high quality design of this diode has produced a device with low leakage current, regularly reproducible characteristics and intrinsic ruggedness. These characteristics make it ideal for heavy duty applications that demand long term reliability.

Table 1. Device summary

Symbol	Value
$I_{F(AV)}$	30 A
V_{RRM}	400 V
$T_j(max)$	175° C
$V_F (typ)$	0.97 V
$t_{rr} (typ)$	24 ns

Features

- Ultrafast switching
- Low reverse current
- Low thermal resistance
- Reduces switching and conduction losses
- High junction temperature
- ECOPACK[®]2 compliant component

1 Characteristics

Table 2. Absolute ratings (limiting values at 25° C, unless otherwise specified)

Symbol	Parameter		Value	Unit
V _R RM	Repetitive peak reverse voltage		400	V
I _F (RMS)	RMS forward current		50	A
I _F (AV)	Average forward current, δ = 0.5	TO-220AC / DO-247 / D ² PAK T _c = 120 °C	30	A
I _F FRM	Repetitive peak forward current	t _p = 10 ms, F = 1 KHz	500	A
I _F FSM	Surge non repetitive forward current	t _p = 10 ms Sinusoidal	300	A
T _{stg}	Storage temperature range		-65 to +175	° C
T _j	Operating junction temperature range		-40 to +175	° C

Table 3. Thermal parameters

Symbol	Parameter		Value	Unit
R _{th(j-c)}	Junction to case	TO-220AC / DO-247 / D ² PAK	1.15	°C/W

Table 4. Static electrical characteristics

Symbol	Parameter	Test conditions		Min	Typ	Max	Unit
I _R ⁽¹⁾	Reverse leakage current	T _j = 25° C	V _R = V _R RM			15	µA
		T _j = 100° C			3	30	
		T _j = 125° C			15	150	
V _F ⁽²⁾	Forward voltage drop	T _j = 25° C	I _F = 15 A			1.26	V
		T _j = 150° C			0.8	1.0	
		T _j = 25° C	I _F = 30 A			1.45	
		T _j = 100° C				1.3	
		T _j = 150° C			0.97	1.2	

1. Pulse test: t_p = 5 ms, δ < 2%
2. Pulse test: t_p = 380 µs, δ < 2%

To evaluate the conduction losses use the following equation:

$$P = 0.9 \times I_{F(AV)} + 0.01 \times I_{F(RMS)}^2$$

Table 5. Dynamic characteristics

Symbol	Parameter	Test conditions	Min	Typ	Max	Unit
t_{rr}	Reverse recovery time	$I_F = 1\text{ A}$, $di_F/dt = -200\text{ A}/\mu\text{s}$, $V_R = 30\text{ V}$, $T_j = 25^\circ\text{ C}$		24	35	ns
		$I_F = 1\text{ A}$, $di_F/dt = -15\text{ A}/\mu\text{s}$, $V_R = 30\text{ V}$, $T_j = 25^\circ\text{ C}$		78	100	
		$I_F = 1\text{ A}$, $I_R = 1\text{ A}$, $I_{RR} = 0.25\text{ A}$, $T_j = 25^\circ\text{ C}$			50	
I_{RM}	Reverse recovery current	$I_F = 30\text{ A}$, $di_F/dt = -200\text{ A}/\mu\text{s}$, $V_R = 320\text{ V}$, $T_j = 125^\circ\text{ C}$		10	14	A
t_{fr}	Forward recovery time	$I_F = 30\text{ A}$, $di_F/dt = 100\text{ A}/\mu\text{s}$, $V_{FR} = 1.1 \times V_{Fmax}$, $T_j = 25^\circ\text{ C}$			500	ns
V_{FP}	Forward recovery voltage	$I_F = 30\text{ A}$, $di_F/dt = 100\text{ A}/\mu\text{s}$, $V_{FR} = 1.1 \times V_{Fmax}$, $T_j = 25^\circ\text{ C}$		2.9		V

Figure 1. Conduction losses versus average current

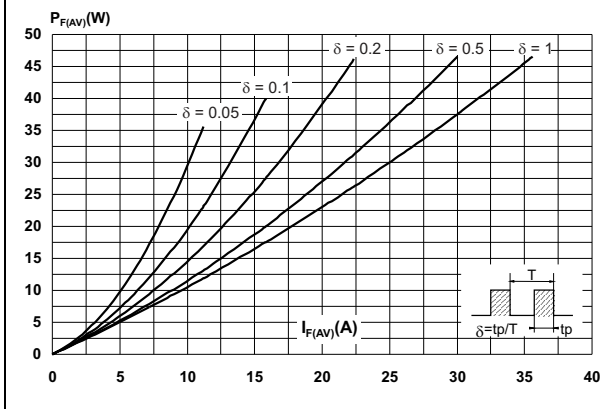

Figure 2. Forward voltage drop versus forward current

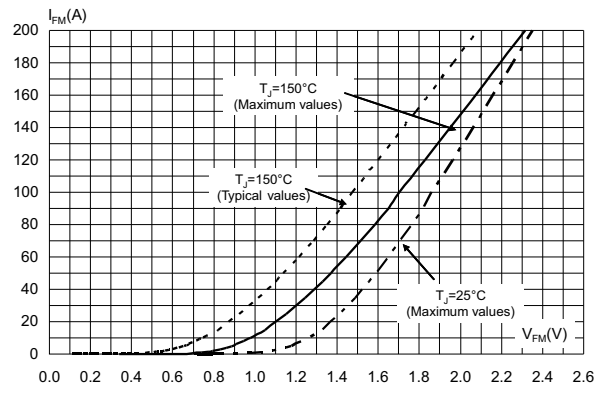

Figure 3. Relative variation of thermal impedance junction to case versus pulse duration

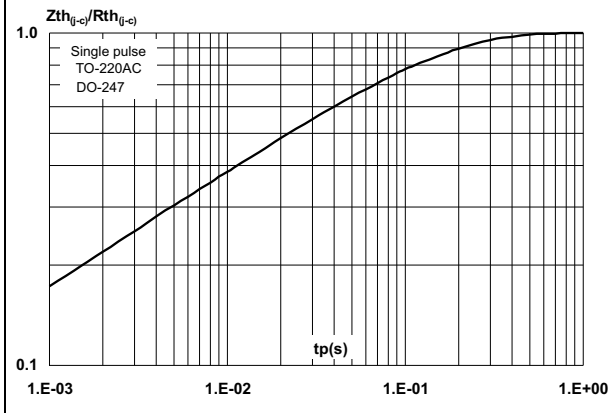

Figure 4. Peak reverse recovery current versus di_F/dt (typical values)

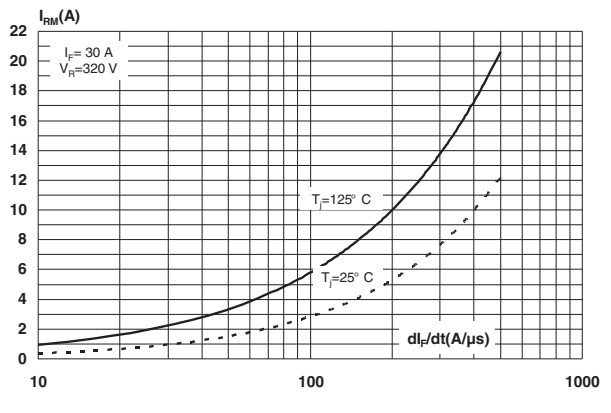

Figure 5. Reverse recovery time versus di_F/dt (typical values)

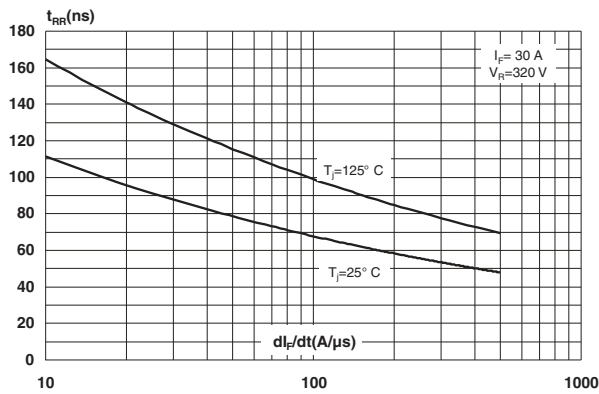

Figure 6. Reverse recovery charges versus di_F/dt (typical values)

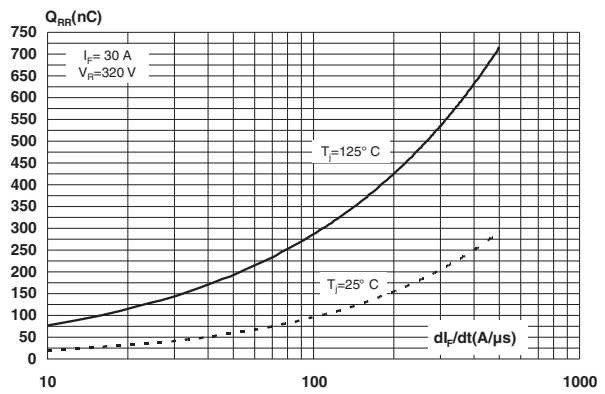

Figure 7. Relative variations of dynamic parameters versus junction temperature

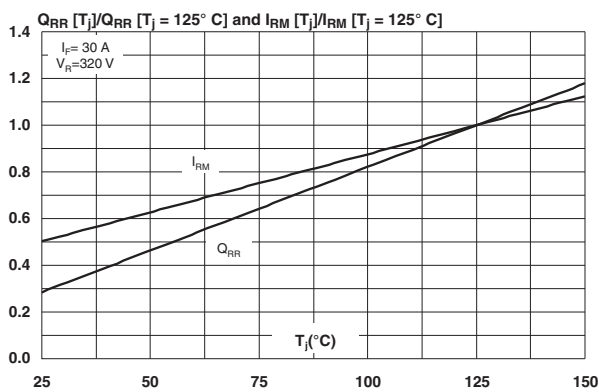

Figure 8. Transient peak forward voltage versus di_F/dt (typical values)

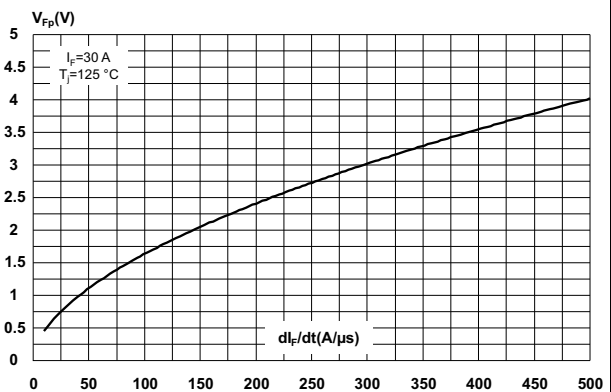

Figure 9. Forward recovery time versus di_F/dt (typical values)

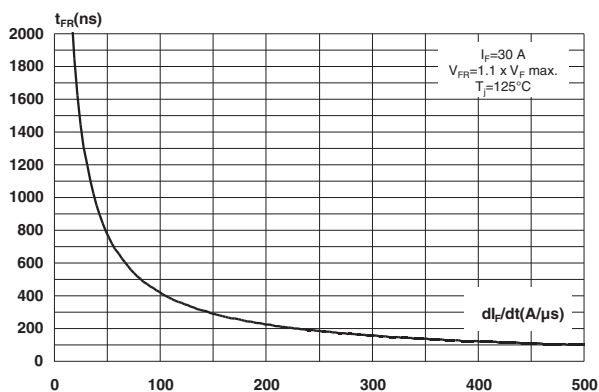

Figure 10. Junction capacitance versus reverse voltage applied (typical values)

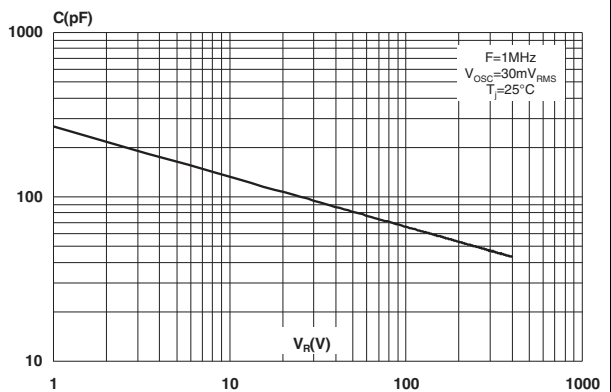
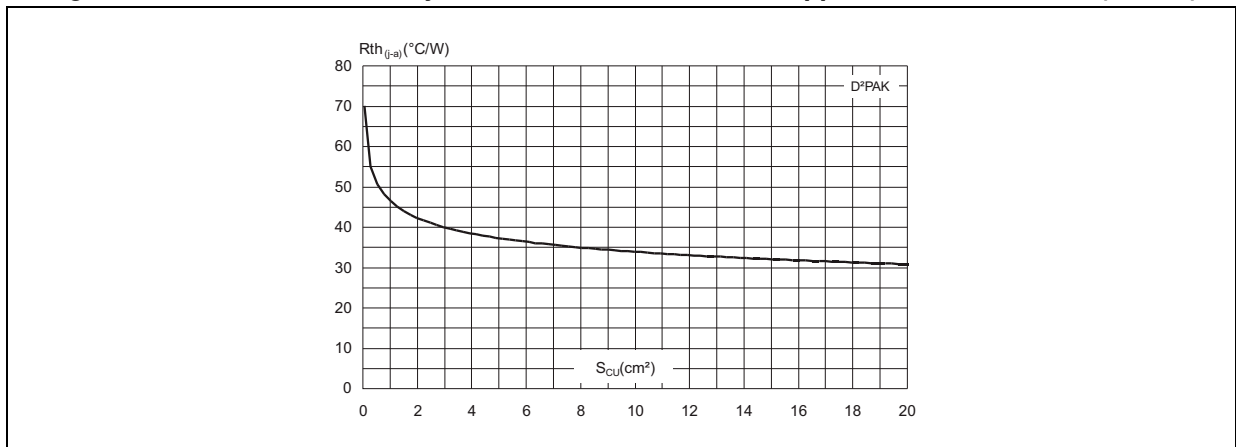

Figure 11. Thermal resistance junction to ambient versus copper surface under tab (D²PAK)



2 Package information

- Epoxy meets UL94, V0
- Lead-free package
- Cooling method: by conduction (C)
- Recommended torque value: 0.55 N·m (TO-220AC)
- Maximum torque value: 0.7 N·m (TO-220AC)

In order to meet environmental requirements, ST offers these devices in different grades of ECOPACK® packages, depending on their level of environmental compliance. ECOPACK® specifications, grade definitions and product status are available at: www.st.com. ECOPACK® is an ST trademark.

2.1 D²PAK package information

Figure 12. D²PAK package outline

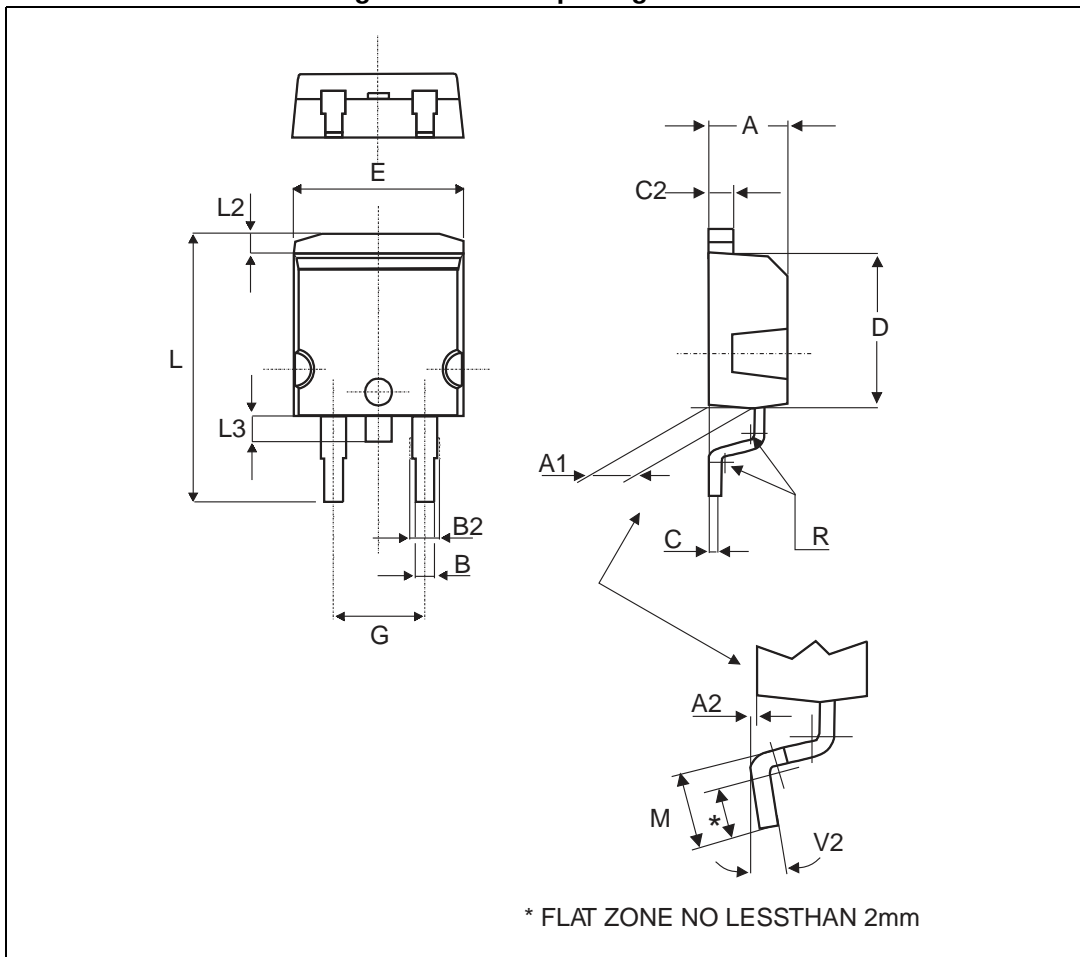
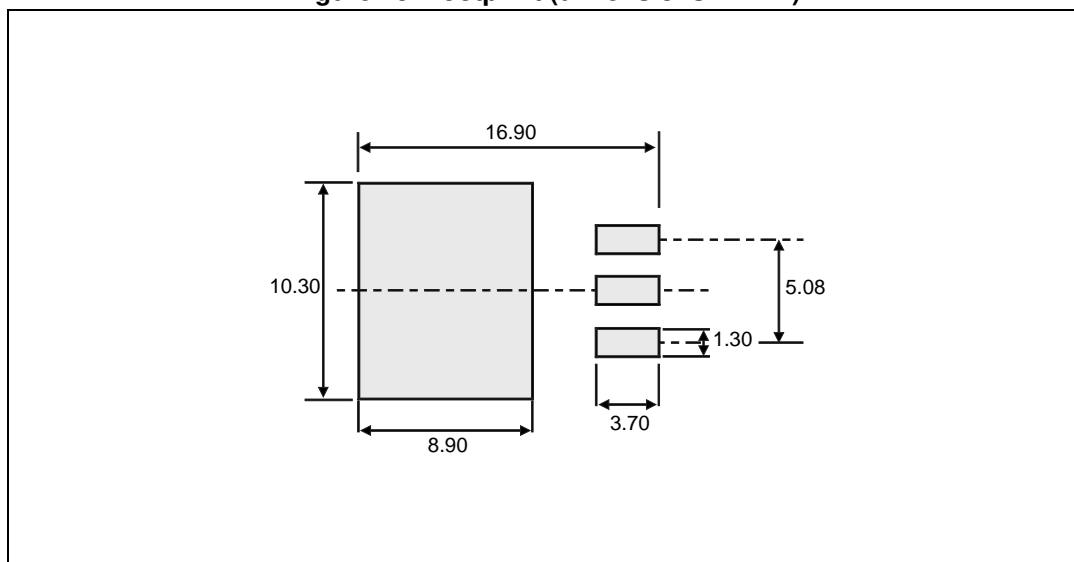

Table 6. D²PAK package mechanical data

Ref.	Dimensions			
	Millimeters		Inches	
	Min.	Max.	Min.	Max.
A	4.40	4.60	0.173	0.181
A1	2.49	2.69	0.098	0.106
A2	0.03	0.23	0.001	0.009
B	0.70	0.93	0.027	0.037
B2	1.14	1.70	0.045	0.067
C	0.45	0.60	0.017	0.024
C2	1.23	1.36	0.048	0.054
D	8.95	9.35	0.352	0.368
E	10.00	10.40	0.393	0.409
G	4.88	5.28	0.192	0.208
L	15.00	15.85	0.590	0.624
L2	1.27	1.40	0.050	0.055
L3	1.40	1.75	0.055	0.069
M	2.40	3.20	0.094	0.126
R	0.40 typ.		0.016 typ.	
V2	0°	8°	0°	8°

Figure 13. Footprint (dimensions in mm)



2.2 DO-247 package information

Figure 14. DO-247 package outline

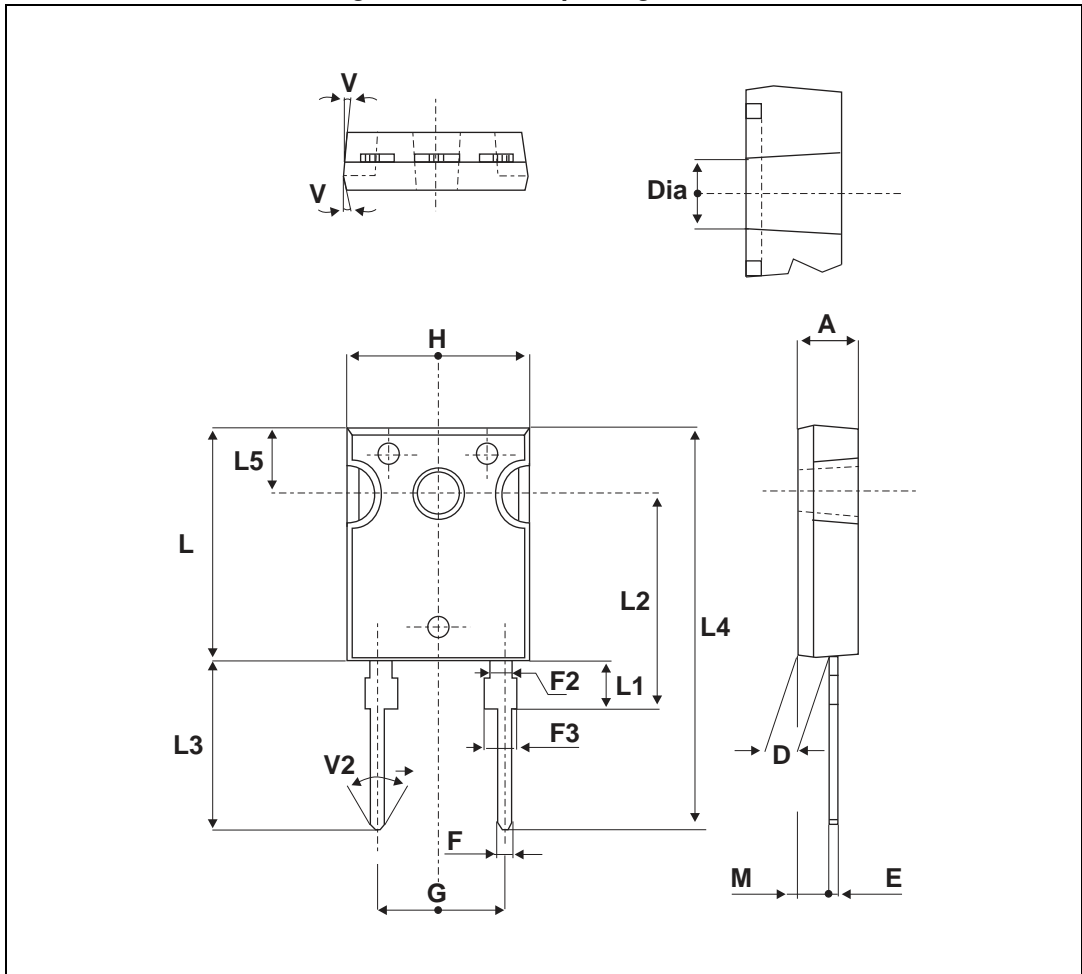

Table 7. DO-247 package mechanical data

Ref.	Dimensions					
	Millimeters			Inches		
	Min.	Typ.	Max.	Min.	Typ.	Max.
A	4.85		5.15	0.191		0.203
D	2.20		2.60	0.086		0.102
E	0.40		0.80	0.015		0.031
F	1.00		1.40	0.039		0.055
F2		2.00			0.078	
F3	2.00		2.40	0.078		0.094
G		10.90			0.429	
H	15.45		15.75	0.608		0.620
L	19.85		20.15	0.781		0.793
L1	3.70		4.30	0.145		0.169
L2		18.50			0.728	
L3	14.20		14.80	0.559		0.582
L4		34.60			1.362	
L5		5.50			0.216	
M	2.00		3.00	0.078		0.118
V		5°			5°	
V2		60°			60°	
Dia.	3.55		3.65	0.139		0.143

2.3 TO-220AC package information

Figure 15. TO-220AC package outline

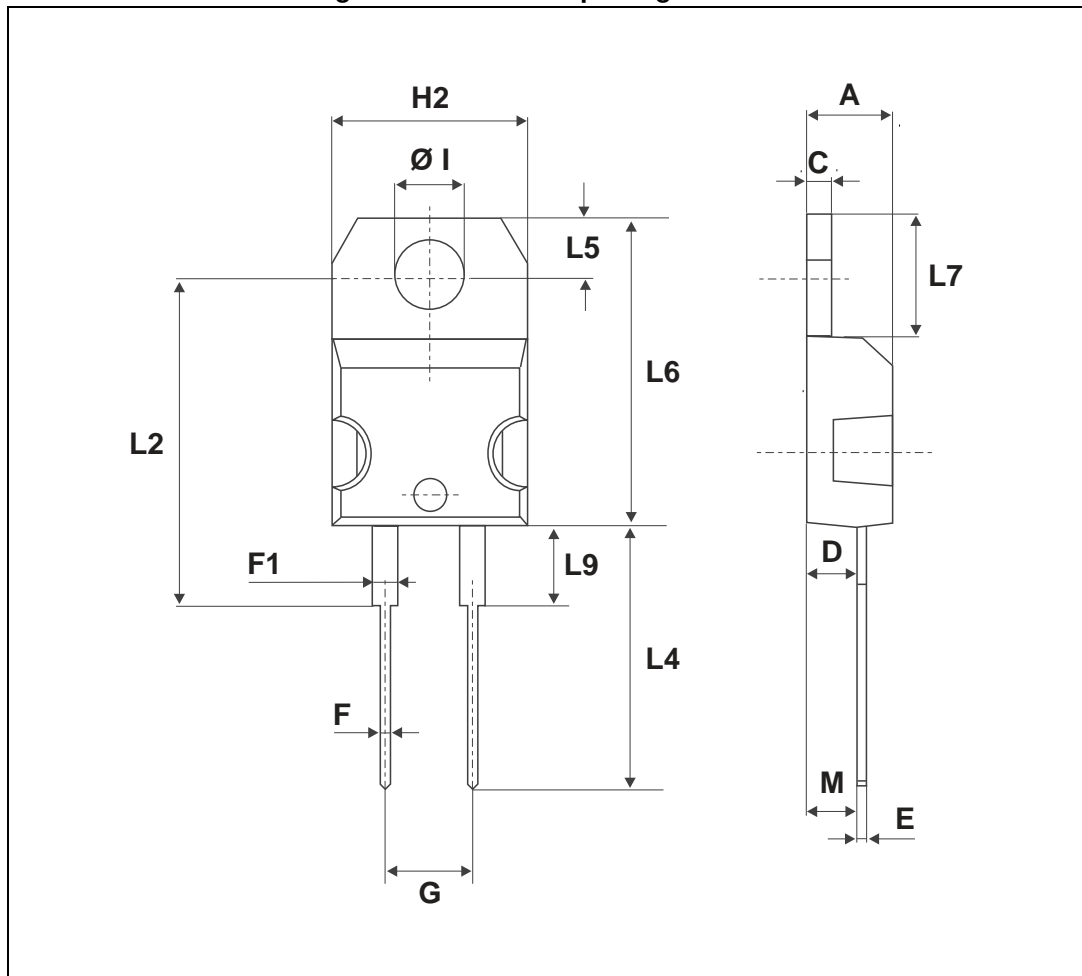

Table 8. TO-220AC package mechanical data

Ref.	Dimensions					
	Millimeters			Inches		
	Min.	Typ.	Max.	Min.	Typ.	Max.
A	4.40		4.60	0.173		0.181
C	1.23		1.32	0.048		0.051
D	2.40		2.72	0.094		0.107
E	0.49		0.70	0.019		0.027
F	0.61		0.88	0.024		0.034
F1	1.14		1.70	0.044		0.066
G	4.95		5.15	0.194		0.202
H2	10.00		10.40	0.393		0.409
L2		16.4			0.645	
L4	13.00		14.00	0.511		0.551
L5	2.65		2.95	0.104		0.116
L6	15.25		15.75	0.600		0.620
L7	6.20		6.60	0.244		0.259
L9	3.50		3.93	0.137		0.154
M		2.6			0.102	
Diam. I	3.75		3.85	0.147		0.151

3 Ordering information

Table 9. Ordering information

Order code	Marking	Package	Weight	Base qty	Delivery mode
STTH30R04D	STTH30R04D	TO-220AC	1.86 g	50	Tube
STTH30R04G	STTH30R04G	D ² PAK	1.48 g	50	Tube
STTH30R04G-TR	STTH30R04G	D ² PAK	1.48 g	1000	Tape and reel
STTH30R04W	STTH30R04W	DO-247	4.40 g	30	Tube

4 Revision history

Table 10. Document revision history

Date	Revision	Description of changes
31-Mar-2007	1	First issue.
11-Dec-2015	2	Updated Table 4 and reformatted to current standard. Removed DOP3I package information.

IMPORTANT NOTICE – PLEASE READ CAREFULLY

STMicroelectronics NV and its subsidiaries ("ST") reserve the right to make changes, corrections, enhancements, modifications, and improvements to ST products and/or to this document at any time without notice. Purchasers should obtain the latest relevant information on ST products before placing orders. ST products are sold pursuant to ST's terms and conditions of sale in place at the time of order acknowledgement.

Purchasers are solely responsible for the choice, selection, and use of ST products and ST assumes no liability for application assistance or the design of Purchasers' products.

No license, express or implied, to any intellectual property right is granted by ST herein.

Resale of ST products with provisions different from the information set forth herein shall void any warranty granted by ST for such product.

ST and the ST logo are trademarks of ST. All other product or service names are the property of their respective owners.

Information in this document supersedes and replaces information previously supplied in any prior versions of this document.

© 2015 STMicroelectronics – All rights reserved