

THIS DRAWING IS UNPUBLISHED. RELEASED FOR PUBLICATION
 © COPYRIGHT 2007 BY - ALL RIGHTS RESERVED.

LOC	DIST	REVISIONS				
P	LTR	DESCRIPTION	DATE	DWN	APVD	
A1	-	C	CUT-OFF CLEARANCE ADDED IN CARRIER STRIP	25FEB2013	PKS	RRP

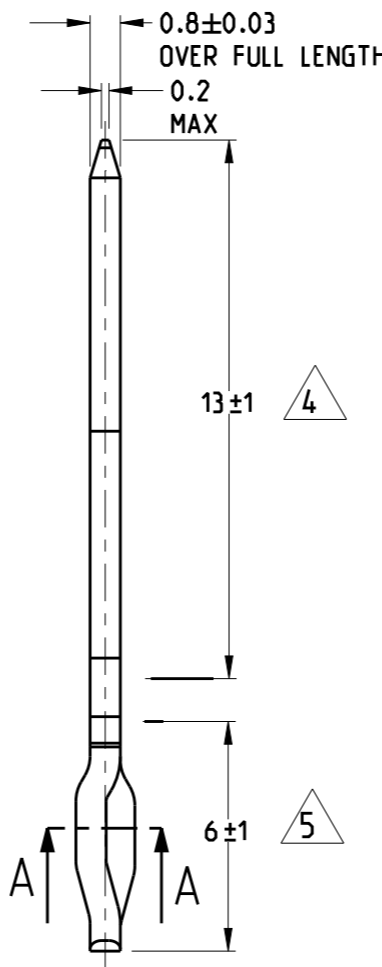
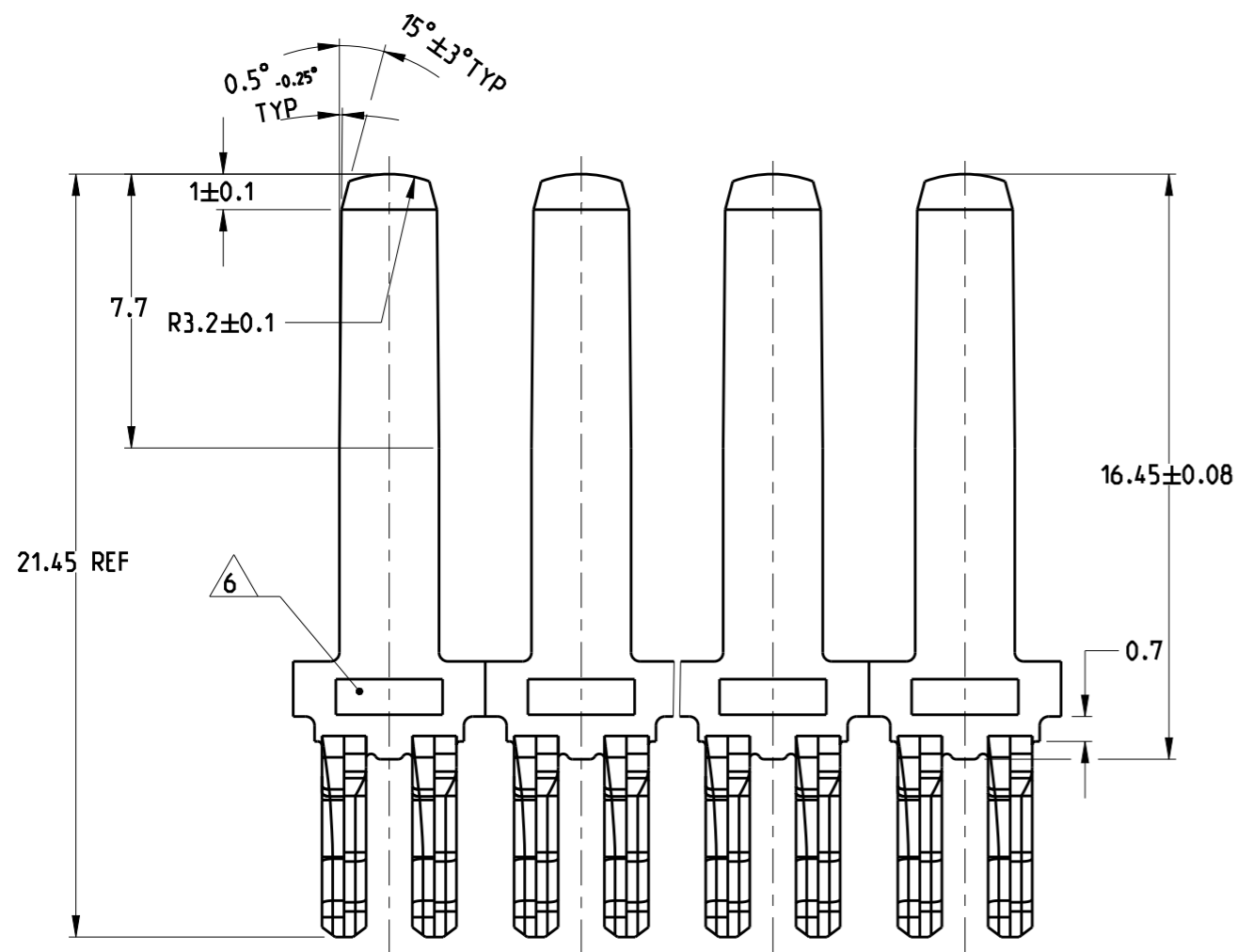

P.C.B HOLE DIM ACTION PIN
 Drilled hole: 1.6±0.025 mm
 Fin. Hole: 1.48±0.08 mm
 Cu-thks: 0.025 to 0.075 mm
 Sn-thks: 0.004 to 0.010 mm

NOTES:

- 1 PHOSPHORBRONZE
- 2 2.54-5.00 µm Sn Over
1.25-2.00 µm Ni
- 3 CUT OFF WIDTH
- 4 1.5-4.0 µm AG over Ni
- 5 2.54-5.00 µm Sn Over
1.25-2.00 µm Ni
- 6 LOGO

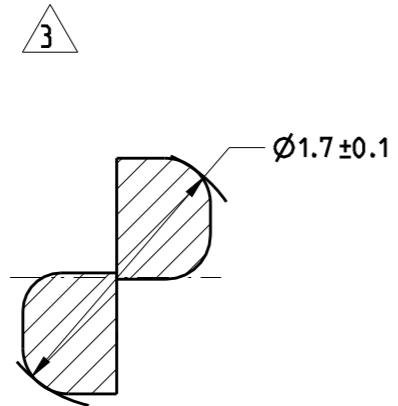

C	4/5	1	1377181-3
C	2	1	1377181-2
REVISION	FINISH	MATERIAL	PART NO

THIS DRAWING IS A CONTROLLED DOCUMENT.

DWN	R.v.Heuven	04-04-00
CHK	A.Bijnen	19-07-01
APVD	A.Bijnen	19-07-01
PRODUCT SPEC	-	-
APPLICATION SPEC	-	-
WEIGHT	-	-
Customer Drawing		

STE TE Connectivity

NAME: 2.8X0.8mm TAB WITH ACTION PIN (1.6-3.2 P.C BOARD THICKNESS.)

SIZE	CAGE CODE	DRAWING NO	RESTRICTED TO
A3	00779	C-1377181	-

SCALE: 5:1 SHEET 1 OF 1 REV C

DIMENSIONS:	TOLERANCES UNLESS OTHERWISE SPECIFIED:
mm	±0.2mm
	0 PLC
	1 PLC
	2 PLC
	3 PLC
	4 PLC
MATERIAL	FINISH
-	-

