

SCM7B47

Isolated Linearized Thermocouple Input Modules



Description

SCM7B47 modules accept a single channel of input from Type J, K, T, E, R, S, B, or N thermocouples. The signal is filtered, isolated, amplified, linearized, and converted to a high-level analog voltage for output to the process control system (Figure 1).

Linearization is achieved by creating a non-linear transfer function through the module itself; refer to AN505. This non-linear transfer function is configured at the factory and is designed to be equal and opposite to the thermocouple non-linearity.

Cold junction compensation (CJC) is performed using an NTC thermistor (see "Additional SCM7B Part Numbers" section for P/N and AN701 for further information) externally mounted under the field-side terminal block on the backpanel (Figure 1). Open thermocouple detection is upscale using a 30nA current source in the input circuitry.

These modules incorporate a five-pole filtering approach to maximize both time and frequency response by taking advantage of both Thomson (Bessel) and Butterworth characteristics. One pole of the filter is on the field side of the isolation barrier; four are on the process control system side.

After the initial field-side filtering, the input signal is chopped by a proprietary chopper circuit and transferred across the transformer isolation barrier, suppressing transmission of common mode spikes and surges. The signal is then reconstructed and filtered for process control system output.

Modules accept a wide 14 - 35VDC power supply range (+24VDC nominal). Their compact packages (2.13"x1.705"x0.605" max) save space and are ideal for high channel density applications. They are designed for easy DIN rail mounting using any of the -DIN backpanels.

Features

- Interfaces to Type J, K, T, E, R, S, B and N Thermocouples
- Linearizes Thermocouple Signals
- Provides High-Level Voltage Outputs
- 1500Vrms Transformer Isolation
- Accuracy, $\pm 0.06\%$ to $\pm 0.16\%$ of Span Typical
- ANSI/IEEE C37.90.1 Transient Protection
- Input Protected to 120Vrms Continuous
- Noise, 1mVp-p (5MHz), 500 μ Vrms (100kHz)
- 160dB CMRR
- 85dB NMR at 60Hz, 80dB at 50Hz
- Easy DIN Rail Mounting
- CSA C/US Certified
- CE and ATEX Compliant

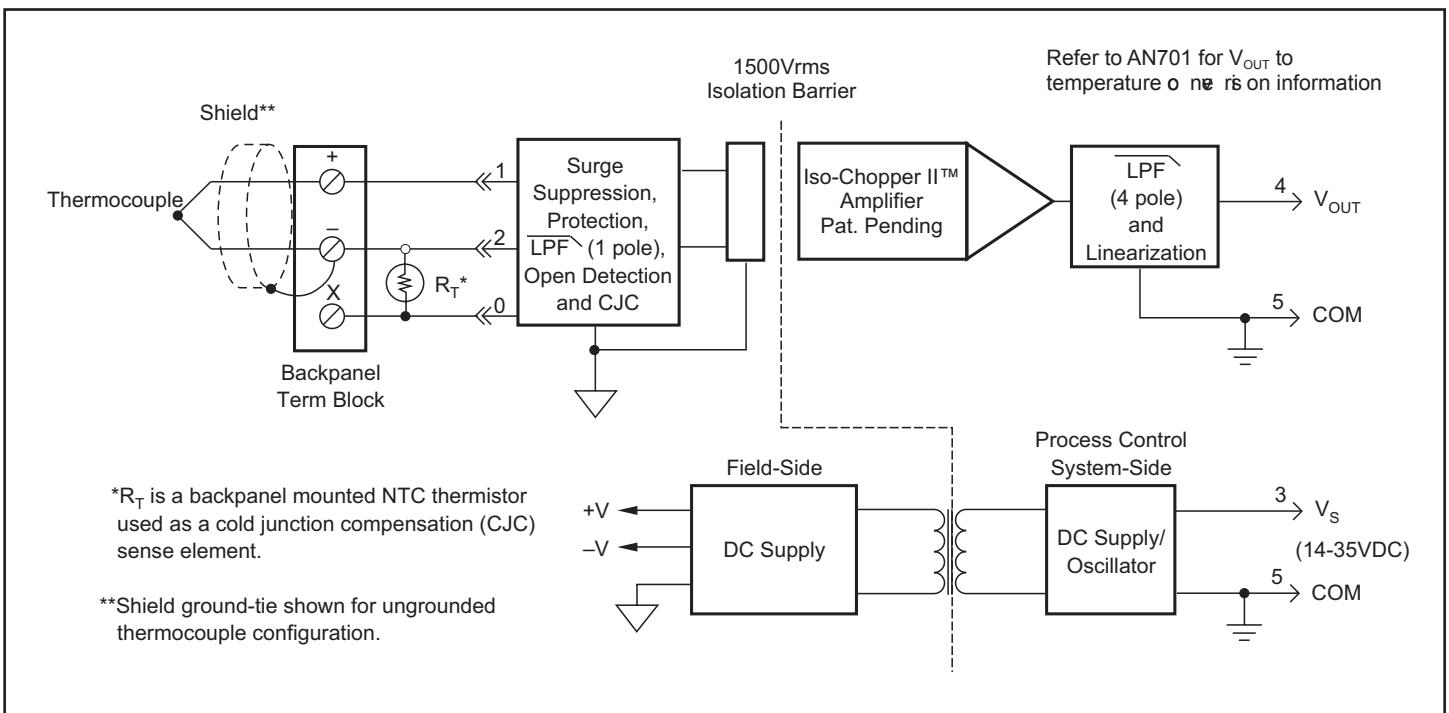

Figure 1: SCM7B47 Block Diagram

Specifications Typical* at 25°C and +24VDC

Module	SCM7B47
Input	
Signal Range	Thermocouple ⁽¹⁾ (See Ordering Information)
Current	-30nA
Resistance	
Normal	50MΩ
Power Off	30kΩ min
Overload	30kΩ min
Protection	
Continuous	120Vrms max
Transient	ANSI/IEEE C37.90.1
Output	
Signal Range ⁽²⁾	†
Effective Available Power ⁽²⁾	40mW
Resistance	<1Ω
Protection	Continuous Short to Ground
Voltage/Current Limit	±12V, ±14mA
CMV (Input-to-Output)	
Continuous	1500Vrms
Transient	ANSI/IEEE C37.90.1
CMRR (50 or 60Hz)	160dB
Accuracy ⁽³⁾	(See Ordering Information)
Stability (-40°C to +85°C)	
Gain	±40ppm/°C
Input Offset	±0.5µV/°C
Zero Suppression	±0.005% V _Z ⁽⁴⁾ /°C
Output Offset	±0.002% Span/°C
Noise	
Peak at 5MHz B/W	1mV
RMS at 10Hz to 100kHz B/W	500µV
Peak at 0.1Hz to 10Hz B/W	1µV RTI ⁽⁵⁾
CJC Accuracy ⁽⁶⁾	±0.25°C Typ, ±1°C max
+5°C to +45°C ambient	
Open Input Response	Upscale
Open Input Detection Time	4 0s
Frequency and Time Response	
Bandwidth, -3dB	3Hz
NMR (50/60Hz)	80/85dB
Step Response, 90% Span	165ms
Supply Voltage	14 to 35VDC
Current ⁽²⁾	16mA
Sensitivity	±0.0001% % _s
Mechanical Dimensions (h)(w)(d)	2.13" x 1.705" x 0.605" max (54.1mm x 43.3mm x 15.4mm max)
Environmental	
Operating Temperature Range	-40°C to +85°C
Storage Temperature Range	-40°C to +85°C
Relative Humidity	0 to 95% Noncondensing
Emissions EN61000-6-4	ISM, Group 1
Radiated, Conducted	Class A
Immunity EN61000-6-2	ISM, Group 1
RF	Performance A ±0.5% Span Error
ESD, EFT	Performance B

NOTES:
 *Contact factory or your local Dataforth sales office for maximum values.
 (1) Thermocouple characteristics per NIST monograph 175, ITS-90.
 (2) Output Range and Supply Current specifications are based on minimum output load resistance. Minimum output load resistance is calculated by V_{out}^2/P_E , where P_E is the output Effective Available Power that guarantees output range, accuracy, and linearity specifications.
 (3) Accuracy includes the effects of repeatability, hysteresis, and conformity.
 (4) V_Z is the nominal input voltage that results in a 0V output.
 (5) RTI = Referenced to Input.
 (6) The CJC sensor accuracy should be added to the module accuracy and thermocouple accuracy to compute overall measurement accuracy.

Ordering Information

Model#	Input Range	Accuracy ⁽³⁾⁽⁵⁾	
		Typical	Max
SCM7B47J-01	0°C to +760°C (+32°F to +1400°F)	±0.11% Span (0.84°C)	±0.32% Span (3.43°C)
SCM7B47J-02	-100°C to +300°C (-148°F to +572°F)	±0.10% Span (0.40°C)	±0.30% Span (1.20°C)
SCM7B47K-03	0°C to +1300°C (+32°F to +2372°F)	±0.11% Span (1.43°C)	±0.32% Span (4.16°C)
SCM7B47K-04	0°C to +600°C (+32°F to +1112°F)	±0.06% Span (0.36°C)	±0.18% Span (1.08°C)
SCM7B47T-05	0°C to +400°C (+32°F to +752°F)	±0.13% Span (0.52°C)	±0.38% Span (1.52°C)
SCM7B47T-06	-100°C to +200°C (-148°F to +392°F)	±0.16% Span (0.48°C)	±0.47% Span (1.41°C)
SCM7B47E-07	0°C to +900°C (+32°F to +1652°F)	±0.11% Span (0.99°C)	±0.34% Span (3.06°C)
SCM7B47R-08	+500°C to +1750°C (+932°F to +3182°F)	±0.10% Span (1.25°C)	±0.30% Span (3.75°C)
SCM7B47S-09	+700°C to +1750°C (+1292°F to +3182°F)	±0.08% Span (0.84°C)	±0.25% Span (2.63°C)
SCM7B47B-10	+800°C to +1800°C (+1472°F to +3272°F)	±0.12% Span (1.20°C)	±0.35% Span (3.50°C)
SCM7B47N-11	+200°C to +1300°C (+392°F to +2372°F)	±0.09% Span (0.99°C)	±0.27% Span (2.97°C)

†Output Ranges Available

Output Range	Part No. Suffix	Example
+1 to +5V	NONE	SCM7B47J-01
0 to +5V	A	SCM7B47J-01A
0 to +10V	D	SCM7B47J-01D

‡Thermocouple Alloy Combinations

Standards: DIN IEC 584, ANSI MC96-1-82, JIS C 1602-1981

Type	Material
J	Iron vs. Copper-Nickel
K	Nickel-Chromium vs. Nickel-Aluminum
T	Copper vs. Copper-Nickel
E	Nickel-Chromium vs. Copper-Nickel
R	Platinum-13% Rhodium vs. Platinum
S	Platinum-10% Rhodium vs. Platinum
B	Platinum-30% Rhodium vs. Platinum-6% Rhodium
N	Nickel-14.2% Chromium-1.4% Silicon vs. Nickel-4.4% Silicon- 0.1% Magnesium

SCM7B