



With simple operation and rapid response time, PMB moisture analyzers offer the top value in their class. The automatic test-setting function enables easy recall for frequent testing of the same items without additional user programming. USB and RS-232 interfaces provide computer and printer connections to store test programs and results. There is no need for additional software to take readings, giving users total freedom to collect data on a production floor or in the field. A single 400-watt halogen bulb heats samples in 1 °C selectable increments. Three heating options give users the flexibility to customize test methods and temperatures for different materials.

Superior connectivity in a moisture analyzer, with two USB ports for data collection and computer or printer communications



Features

- Vivid, backlit LCD easily visible in any lighting conditions
- Programmable backlight can be set to “always on,” “always off” or “light only when weighing”
- Capacity tracker built into display for easily monitoring possible overloads
- Scratch-resistant aluminum housing protects internal components
- Color-coded keys facilitate quick recognition of the most frequently used buttons
- Pan lifter allows easy placement and removal of samples
- Optional RS-232 interface is available to provide speedy connection to computers and printers
- USB host for memory card and USB I/O interface
- USB interface included for faster data communication
- Temperature range 50°C to 160°C in one-degree increments
- Three settings for heating sample include ramp-up, stepped temperatures and single temperature
- Seven preset drying modes allow test routines for several products
- Audible overload alarm warns when capacity has been exceeded
- Testing can be set to start automatically when lid closes
- Calibration for temperature and weight
- Multilingual display permits use in various regions
- Quick and easy configuration using the keypad
- Zero-tracking feature ensures display returns to zero reading
- Internal memory stores 49 different recipes and up to 99 test results, and additional test results and settings can be stored on a flash drive
- Power cord

Applications

- Weighing
- Moisture determination

About ADAM:

For more than 40 years, professionals worldwide have relied on Adam Equipment for an extensive selection of dependable and affordable weighing equipment. Adam provides the right balance of speed, performance and value.

Product Details

Model	PMB 53	PMB 163	PMB 202
Capacity	50g	160g	200g
Readability	0.001g / 0.01%	0.001g / 0.01%	0.01g / 0.05%
Pan Size	3.9" ø / 100mm ø		
Weighing Units	g, %M, %S, ATRO %M, ATRO %S		
Stabilization Time (sec)	4		
Interface	RS-232, USB		
Memory Settings	Internal memory stores up to 99 test results and 49 programmable user settings External USB drive for limitless data storage of test results and settings		
Calibration	External calibration		
Display	Backlit LCD with 0.9" / 24mm-high digits		
Power Supply	Power cord		
Operating Temperature	0° to 40°C / 32° to 104°F		
Housing	Die-cast aluminum		
Overall Dim.	9.8"x14.2"x7.3" / 250x360x185mm (wxdxh)		
Net Weight	13.2lb / 6kg		

Accessories

Item number	Description
104008036	Anti-vibration table
1070010636	Temperature calibration kit
301208188	In-use wet cover
3074010266	RS-232 cable (null-modem)
3074010267	USB cable
1120011156	ATP thermal printer
3126011263	ATP thermal printer paper
3126011281	ATP thermal printer paper (pack of 10)
307140001	Disposable sample pans (pack of 250)
700100046	Kensington-type lock and cable
600002028	AdamDU data collection program
700660290	Calibration certificate
700100014	F1 50g Calibration Weight
700100007	F1 100g Calibration Weight
700100012	F1 200g Calibration Weight

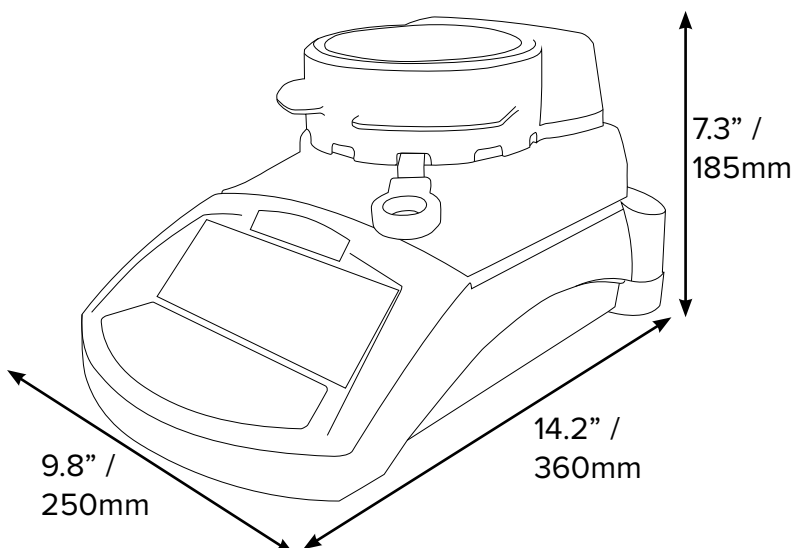

Key Accessories



ATP Thermal Printer

Easy-to-use features combined with quick set-up equals a truly versatile thermal printer. A single push-button feed key and three easy-to-read LED indicators make operation simple.



Temperature Calibration Kit

The temperature calibration kit comes in a cushioned carrying case for protection and easy transportation. The temperature measuring range is from -50°C to 300°C, with readings in Celsius or Fahrenheit.



Disposable Sample Pans

When weighing chemicals or other messy items, the use of disposable pans can help keep the permanent pan clean.

Supplied by

www.adamequipment.com