

RI 4194

LAN 10 GBPS

FEEDTHRU FILTER

Panel mountable
LAN 10 Gbps
feedthru filter



OVERVIEW

The RI 4194 is a feedthru filter for all types of applications where LAN signals need to be fed through a shielded wall.

APPLICATION

Primarily designed to fit in Ranatec's Shield Boxes but can be used separately.

ELECTRICAL INTERFACES

The physical connectors are located at each end. The filter is reciprocal, which means the mounting direction can be either way.

MECHANICAL INTERFACES

The RI 4194 is prepared for panel mounting with two threaded M3 screw holes. It is delivered with an EMI/RFI shielding gasket for simple and reliable mounting.

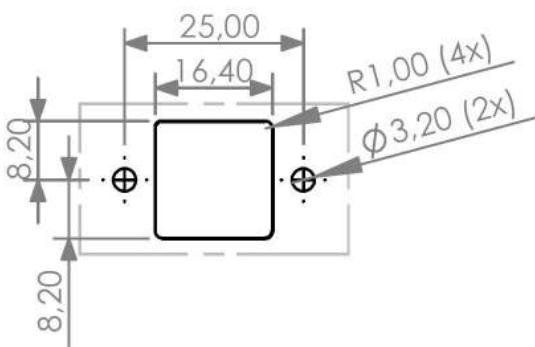

Panel cut-out recommendation (mm)

FEATURES

- LAN 10 Gbps compatible
- Panel mountable

SPECIFICATION

Connector front:	RJ45 jack
Connector back:	RJ45 jack
Material:	Aluminium
Dimensions:	36x64x24 mm
Weight:	90g

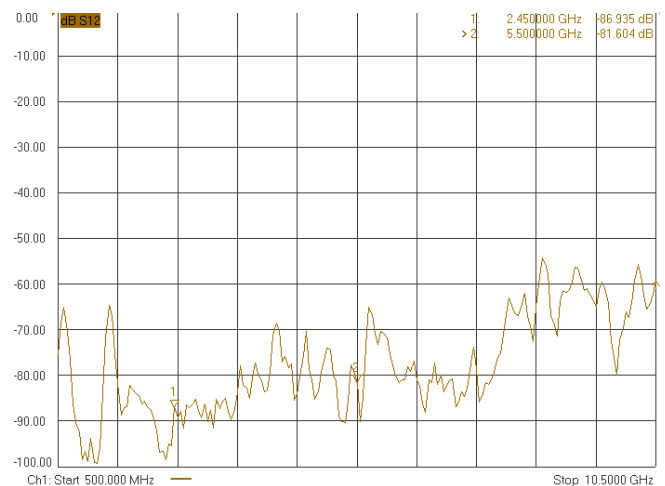

Typical filter suppression

ORDERING

RI 4194 LAN 10 Gbps Feedthru Filter