

# Features

# Reference Design

- Complete isolated solution for CAN bus
- Contains galvanically-isolated CAN transceiver ISO1042
- Contains R1SX-3.305/H - 3.3V to 5V 1W DC-DC converter with 3kVDC isolation
- Up to 5Mbit data rate in CAN FD mode
- Input and output test points
- Meets ISO11898-2 (2016) standard

## R-REF03-CAN1

### Description

The R-REF03-CAN1 Reference Board demonstrates the ISO1042 isolated CAN transceiver supplied by the R1SX-3.305/H isolated DC/DC converter. To supply the reference board only one 3.3V external supply is required. The green LED indicates the presence of the VCC2 supply on the secondary (CAN bus) side. The reference board allows designers to quickly develop and analyze isolated systems.

The reference board is pre-configured with a “split” termination network (R2 and R4) with a common-mode capacitance and additional caps (C7, C8 and C9) on the CAN bus for protection. It also includes an option to populate a 120-Ω resistor R3 which can be used with the EVM as a terminated line end (CAN is defined for 120Ω impedance twisted pair cable). Protection components like TVS diodes (D1) and common mode (CM) choke (L1) are also provided with bypass paths if necessary. Using these options, the customer is allowed installation of the desired components.

The output of the R1SX-3.305/H (U2) is used to supply the secondary (CAN bus) side of the digital isolator U1 and the green LED (LED1) which indicates the presence of the voltage on VCC2. VCC2 is loaded with a 120Ω resistor R7, too, to keep the VCC2 safely below 5.3V. Since the reference board internally consumes about 80mA from the output of the U2, a user can use about 120mA to supply circuits outside of this reference board through connector J2-1 or test point TP10.

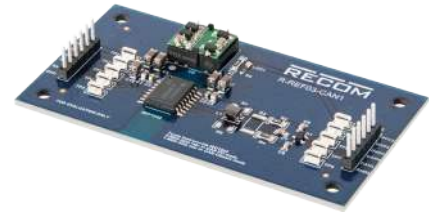

### R-REF03-CAN1 Top view

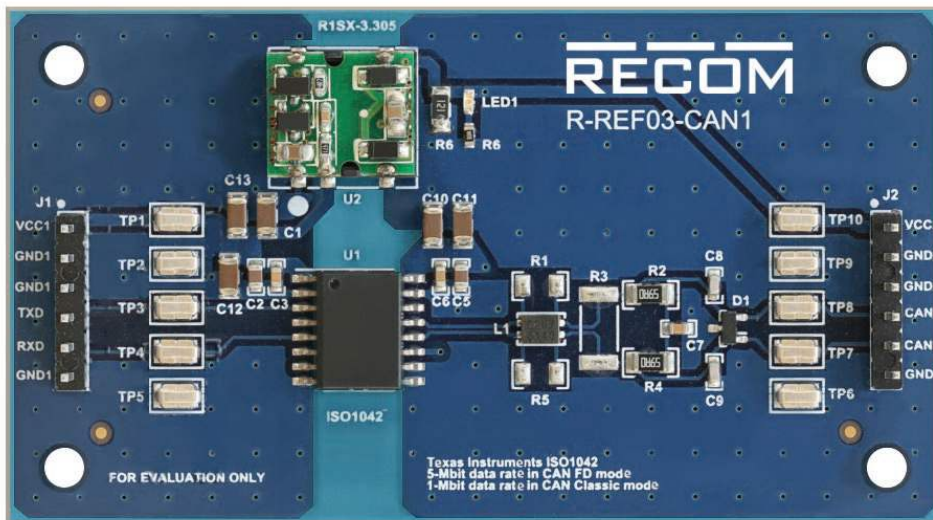

#### Caution:

ESD sensitive. Always follow ESD preventative procedures when handling the product!

**Specifications** (measured @ Ta= 25°C, full load after warm up unless otherwise stated)

**BASIC CHARACTERISTICS of the R1SX-3.305/H**

Parameter	Condition			Min.	Typ.	Max.
Input Voltage Range				±10.0%		
Internal Operating Frequency				20kHz	60kHz	100kHz
Output Ripple and Noise <sup>(1)</sup>	20MHz BW					100mVp-p
Output Accuracy						±5.0%
Isolation Voltage	I/P to O/P	with suffix "/H"	tested for 1 second rated for 1 minute			3kVDC 1.5kVAC
Isolation Resistance				10GΩ		
Isolation Capacitance						70pF
Leakage Current						3μA
Operating Temperature Range				-40°C to +100°C		
Operating Altitude						5000m

**Notes:**

Note1: Measurements are made with a 0.1μF MLCC across output. (low ESR)

**Footprint Details of R1SX (mm)**

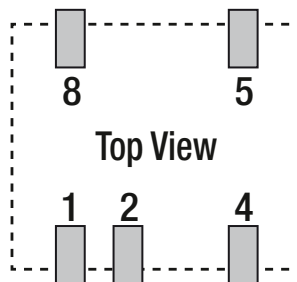

**Pin Connection**

Pin #	Single
1	-Vin
2	+Vin
4	-Vout
5	+Vout
8	NC

NC= no connection

**Basic Specification of the ISO1042**

The ISO1042 device is a galvanically-isolated controller area network (CAN) transceiver that meets the specifications of the ISO11898-2 (2016) standard. The device supports up to 5-Mbps data rate in CAN FD mode allowing much faster transfer of payload compared to classic CAN. This device uses a silicon dioxide (SiO<sub>2</sub>) insulation barrier with a withstand voltage of 5000 VRMS. Used in conjunction with isolated power supplies like R1SX from RECOM, the device prevents noise currents on a data bus or other circuits from entering the local ground and interfering with or damaging sensitive circuitry.

ISO1042 accepts 1.8V, 2.5V, 3.3V or 5.5V supply voltage on the primary side (VCC1) and 5V on the secondary (VCC2).

For more details about the ISO1042 please visit [www.ti.com/product/iso1042](http://www.ti.com/product/iso1042)

**Notes:**

Note2: The reference board may contain pre-production version of the ISO1042. This pre-production version part number is XISO1042 and this part number is printed on the IC. If your board is populated with the XISO1042, the prototype device waiver from Texas Instruments (included at the end of this document) is applicable.

Specifications (measured @ Ta= 25°C, full load after warm up unless otherwise stated)

### Typical Switching Waveforms

Input and output waveforms of the reference board for a 5Mbit signal

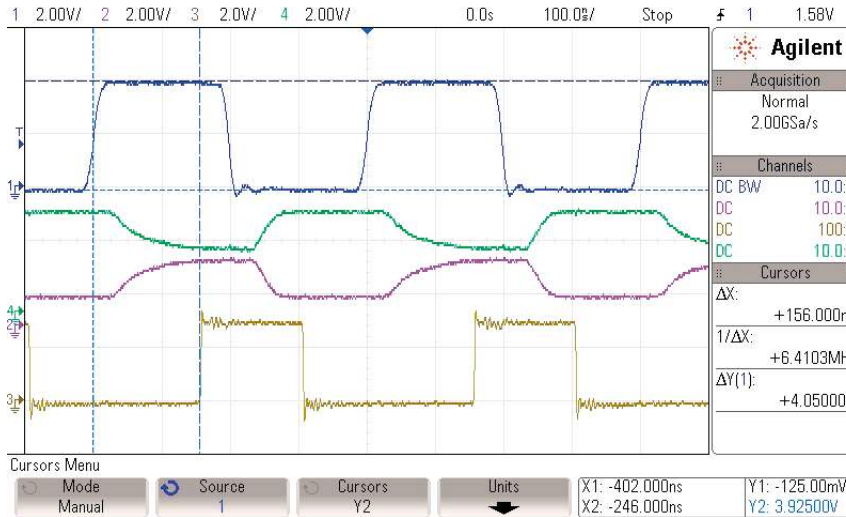

CH1 - TXD  
CH2 - CANL  
CH3 - RXD  
CH4 - CANH

### Quick Start Guide

- Apply 3.3V to VCC1/GND1 and observe 5V on the VCC2/GND2. The green LED on the board should light up
- Inject test signal up to 5-Mbit into the TXD input pin (TXD/GND1) using a signal generator or other source
- Check the CANH and CANL signals with a scope on the secondary side (CANH/GND2 and CANL/GND2)
- Check the RXD signal with a scope on the primary side (RXD/GND1)
- Turn off the signal generator
- Turn off the 3.3V supply. The LED should turn off

### Basic Test Setup

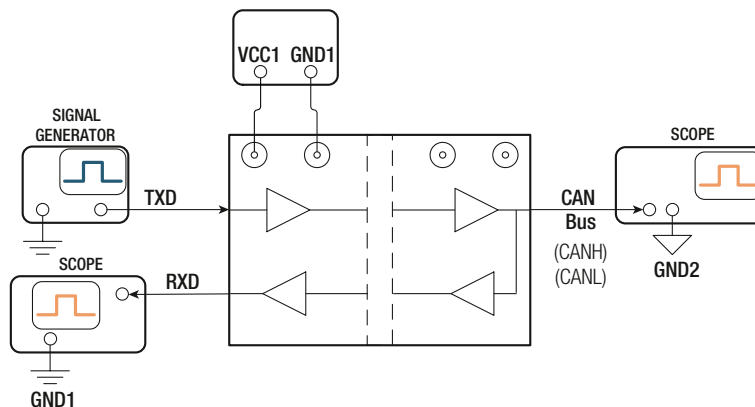

### Connector Description

#### Con1

Pin	Name	Description	Test Point
1	VCC1	Primary Supply 3.3V	TP1
2	GND1	Primary Ground	TP2
3	GND1	Primary Ground	
4	TXD	CAN transmit data input	TP3
5	RXD	CAN receive data output	TP4
6	GND1	Primary Ground	TP5

#### Con2

Pin	Name	Description	Test Point
1	VCC2	Secondary Supply 5V	TP10
2	GND2	Secondary Ground	TP9
3	GND2	Secondary Ground	
4	CANH	High-level CAN bus line	TP8
5	CANL	Low-level CAN bus line	TP7
6	GND2	Secondary Ground	TP6

Specifications (measured @ Ta= 25°C, full load after warm up unless otherwise stated)

Schematic

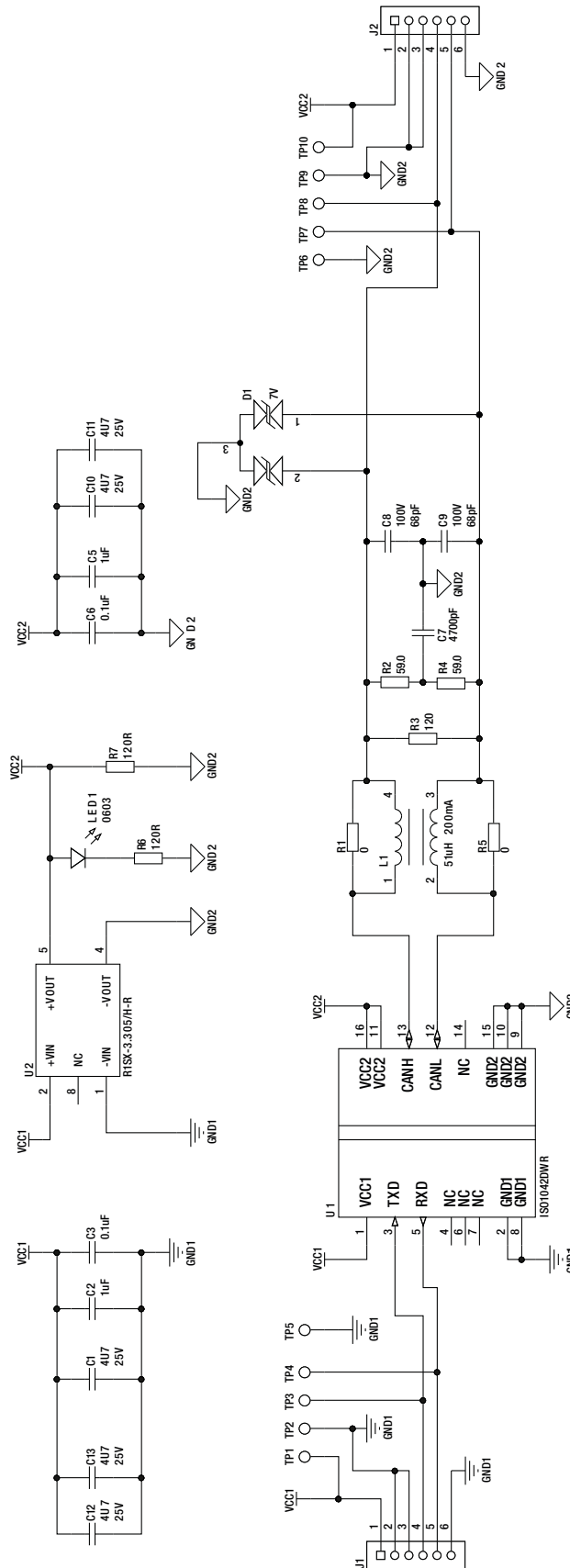

Specifications (measured @ Ta= 25°C, full load after warm up unless otherwise stated)

## DIMENSION AND PHYSICAL CHARACTERISTICS

Parameter	Type	Value
Dimension (LxWxH)		81.28 x 44.96 x 18.0mm
Weight		18.0g typ.

## Layout

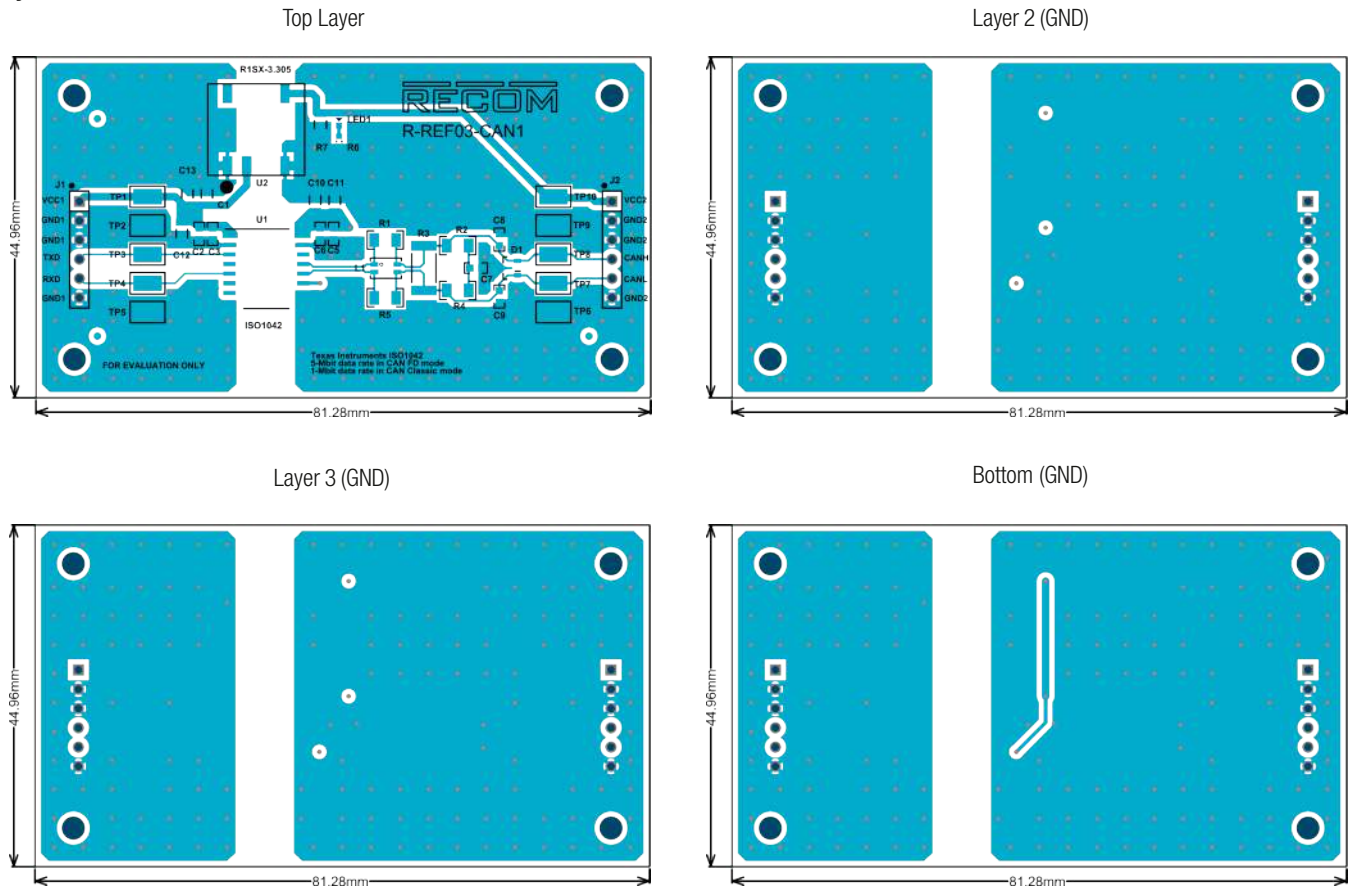

### Notes:

Note3: Visit [www.recom-power.com/eval-ref-boards](http://www.recom-power.com/eval-ref-boards) to download the Gerber files

## BOM

Comp.	Description	Manufacturer Part Number	Manufacturer	Qty.
U1	Isolated CAN transceiver	ISO1042DWR or XISO1042DWR	TI	1
U2	Isolated DC/DC converter 3.3V to 5V 3kVDC	R1SX-3.305 /H	RECOM	1
L1	Coupled inductor, 51 $\mu$ H, 0.2 A, 0.7 ohm, SMD	ACT1210-510-2P-TL00	TDK	1
R6	RES, 120, 1%, 0.1 W, 0603		Yageo	1
R1, R5	RES, 0, 5%, 0.25 W, 1206		Yageo	not mounted
R3	RES, 120, 1%, 1 W, 2512		Yageo	not mounted
R2, R4	RES, 59.0, 1%, 0.25 W, 1206		Yageo	2
R7	RES, 120, 1%, 0.25 W, 1206		Yageo	1
C7	CAP, CERM, 4700 pF, 50 V, +/- 10%, X7R, 0603		Murata	1

continued on next page

## Specifications (measured @ Ta= 25°C, full load after warm up unless otherwise stated)

### BOM

Comp.	Description	Manufacturer Part Number	Manufacturer	Qty.
C8, C9	CAP, CERM, 68 pF, 100 V, +/- 5%, COG/NPO, 0603		Vishay	2
C2, C5	CAP, CERM, 1 uF, 50 V, +/- 10%, X7R, 0603		TDK	2
C3, C6	CAP, CERM, 0.1 uF, 25 V, +/- 5%, X7R, 0603		AVX	2
C1, C10, C11, C12, C13	Cap Cer 1206 50V 4.7uF X7R 10%		TDK	5
D1	Diode, TVS, Bi, 7 V, SOT-23	CDSOT23-SM712	Bourns	1
LED1	LED bright green 0603	150060VS75000	Würth	1
J1, J2	Connector Header Through Hole 6 position 0.100" (2.54mm)	PEC06SAAN	Sullins	2
TP1-TP10	Test Point, Miniature, SMT	5019	Keystone	10
---	snap in spacer 5mm with 3mm hole	709440800	Würth	4

### PACKAGING INFORMATION

Parameter	Type	Value
Packaging Dimension (LxWxH)	carton	200.0 x 135.0 x 68.0mm
Packaging Quantity		1pcs

### Contents

- R-REF03-CAN1 Reference Design
- Terms and Conditions

### Prototype Device Waiver from Texas Instruments

The following devices are prototypes:

XISO1042DRW  
XISO1042DWR-isolated CAN Transceiver With 70-V Bus Fault Protection and Flexible Data Rate

The Texas Instruments products ordered are experimental/prototype for which quality assurance, reliability performance testing and/or process qualification may not have been completed. In some cases, and without limitation, they may include, utilize, or be related to new and emerging technologies that are not presently well defined or understood, or for which industry standards are not yet defined. These experimental products are intended for internal use and evaluation only and are not authorized for any use in production. All specifications are preliminary and TI reserves the right to modify or discontinue the products at any time. The products are provided strictly "as is" and with all faults. TI hereby expressly disclaims all warranties, explicit or implied, regarding the products, including but not limited to any epidemic failure warranty or implied warranties of merchant ability or fitness for a particular purpose.

TI experimental and prototype products are being evaluated by customers for use in many types of applications and systems, including in some cases high-voltage and other potentially dangerous applications; you are solely responsible for evaluating and maintaining safety in your products, facilities, and activities, and these products, materials, and related applications should be handled only by qualified personnel who fully understand and can mitigate applicable safety risks. You should review all safety information and notices provided by TI with respect to the product(s), and are responsible for fully complying with any such provided safety precautions or notices, in addition to determining appropriate safeguards and handling for your intended uses and users of these items.

You acknowledge full and exclusive responsibility to assure the safety of your activities and products and compliance of your activities and products with all applicable laws, regulations, and other applicable requirements. You may not use any TI products in life-critical medical equipment, or any medical product where failure of such product could cause serious bodily injury or death, unless authorized officers of the parties have executed a special contract specifically governing such use. You shall fully indemnify TI and its representatives against any claims or damages arising out of any use of TI products that is not expressly authorized by TI.

Note to distributors: experimental/prototype products shall only be supplied by distributor to the end-user customer as specified by Texas Instruments. If the specified end-user customer does not take possession of the products, distributor agrees to return all such products to Texas Instruments. Distributor shall fully indemnify TI and its representatives against damages arising out of any unauthorized supply of the products.

The product information and specifications may be subject to changes even without prior written notice. The product has been designed for various applications; its suitability lies in the responsibility of each customer. The products are not authorized for use in safety-critical applications without RECOM's explicit written consent. A safety-critical application is an application where a failure may reasonably be expected to endanger or cause loss of life, inflict bodily harm or damage property. The applicant shall indemnify and hold harmless RECOM, its affiliated companies and its representatives against any damage claims in connection with the unauthorized use of RECOM products in such safety-critical applications.